

WALL-MOUNT KIT

Hinged platform for a PROLINE sloped-front enclosure pivots 90 degrees from wall bracket, allowing complete access to rear of the sloped-front enclosure. The kit can be installed to pivot left or right and locks securely in position against a wall. Pivot pin is removable. Platform can support equipment weighing up to 300 lb. and includes holes to mount 600-mm wide sloped fronts in two positions. RAL 7035 textured light-gray polyester powder paint finish. Includes

Top-Unit-to-Frame Joining Kit (catalog number PJSTF6) to provide a watertight and dusttight seal to the sloped front.

BULLETIN: P9

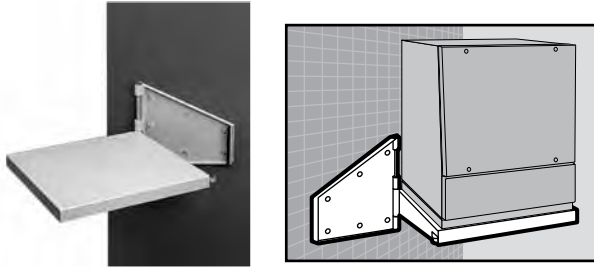
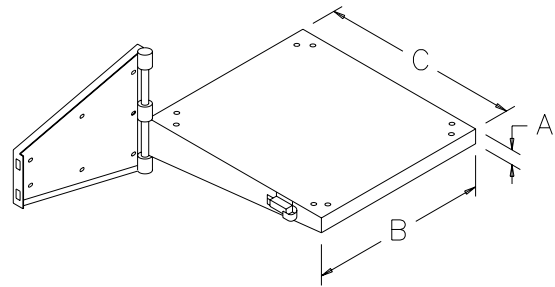

87799062

Catalog Number	AxBxC in./mm	Description
PWMK66	2.00 x 24.00 x 26.88 51 x 610 x 683	Steel

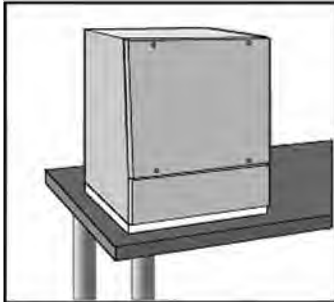
BASES FOR SLOPED FRONT

Closes off open bottom of sloped-front enclosures that are table-top mounted or suspended from overhead. Base is 14 gauge steel and has a ground stud provided. Foam-in-place gasket assures a water-tight and dust-tight seal. Steel bases are finished with RAL 7035 textured light-gray polyester powder paint. A top support bracket can be installed inside a 600-mm wide base for reinforcement when a COMPACT™ Pendant Arm Series 4 System 50, 60 or 80 is attached from below.

BULLETIN: P20, P20S, P9, P9S

0-mm Base

Catalog Number	Description	D mm/in.	W mm/in.
PBS66	Steel	542 21.34	608 23.94
PBS86	Steel	542 21.34	808 31.81
PBS126	Steel	542 21.34	1208 47.56

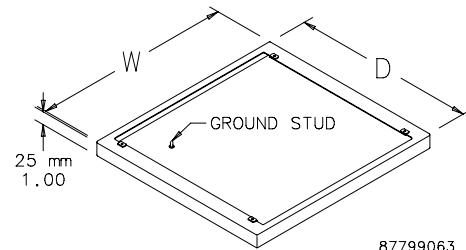

87799063

100-mm Base

Catalog Number	Description	D mm/in.	W mm/in.
PB166	Steel	559 22.01	599 23.58
PB166SS	Stainless Steel	559 22.01	599 23.58
PB186	Steel	759 29.88	599 23.58

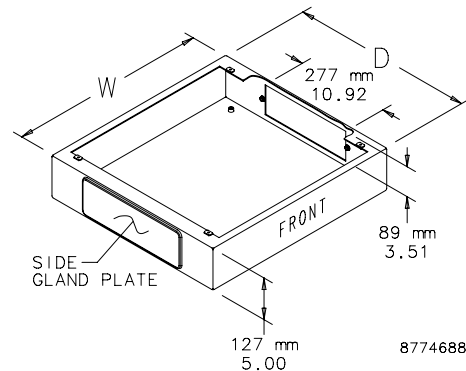

87746889

SUPPORT BRACKET

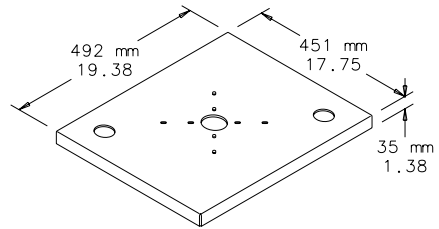
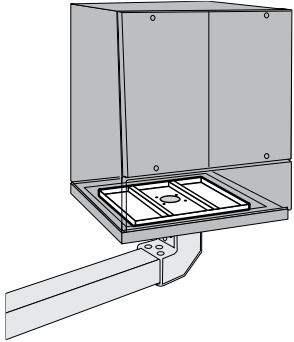

A Support Bracket is required when suspending a 600-mm wide sloped-front enclosure from above. The rigid bracket mounts inside the enclosure to stiffen its top. Bracket has prepunched holes to fit COMPACT™ Pendant Arm Series 4 Systems 50, 60 and 80 flange couplings as well as swivel tilts. Bracket is used as a template to drill holes in sloped front. Bracket is .125-inch-thick aluminum and is furnished with mounting bolts and seals. A support bracket can also be used inside a base for Series 4 System 50, 60 and 80 sloped front when mounting from below.

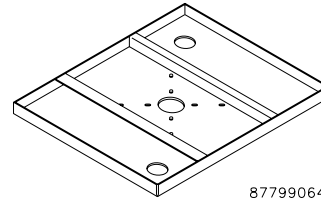

87799064

BULLETIN: P9

Catalog Number	Description
PTS66	Support Bracket

BASE WITH CUTOUT FOR SLOPED FRONT

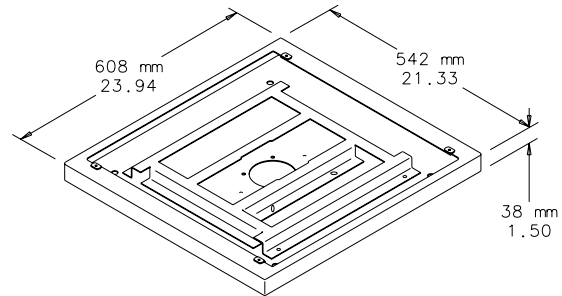
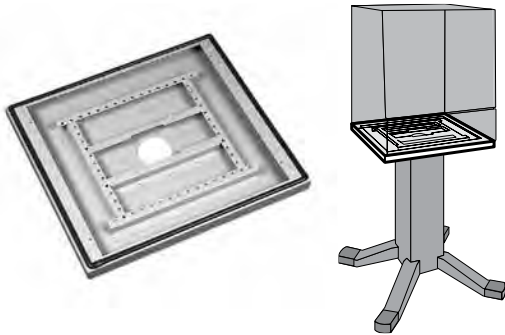

87746890

Closes off open bottom of sloped-front enclosures. Also fits Series 4 Pendant Arm Flange Coupling Systems 80 and 80/140. The 14 gauge steel base has a stiffener framework attached to the inside and mounting holes that provide a rigid mounting means for 8.00 x 8.00-in. pedestal, pedestal extension, swivel tilt or angle adapter. Base has foam-in-place gasket and RAL 7035 textured light-gray polyester powder paint finish. Mounting hardware is furnished.

BULLETIN: P9, P9S

Catalog Number	Description
PBSK66	Steel
PBSK66SS	Stainless Steel