

# IsoCenter™ Series

isolation transformer system

provides isolation from electrical and electronic noise, while deriving a new neutral ground bond point

## features:

- Very high efficiency toroidal transformer - greater than 98%
- Negligible magnetic leakage allows mounting within a rack
- Integrated load center with four 20Amp circuits all on the same phase
- 100,000Amp 2-stage surge and spike protection with dry contact status notification available on select models
- Eighteen receptacles for load distribution
- Input voltage monitoring with shutdown function
- Main circuit breaker
- ETL Listed in the US and Canada



ISOCTR-5R-208-NS



rear view  
ISOCTR-5R-208/240-2



rear view  
ISOCTR-5R-208/240-NS

## specifications:

Patented EIA compliant IsoCenter™ Isolation Transformer shall be Middle Atlantic Products model # ISOCTR-5R-\_\_\_\_-\_\_\_\_ (refer to chart) with (240, 208) input voltages and 5KVA of power with a new separately derived neutral ground bond point. The IsoCenter™ unit shall be controlled by a main circuit breaker located in the front of the unit which will disconnect all primary power to the transformer. The isolation transformer shall have a Faraday shield to attenuate common-mode noise. The IsoCenter™ shall have less than 250 milligauss magnetic field measured at the chassis. The IsoCenter™ shall produce no more than 27dB of acoustic noise. Select IsoCenter™ models shall have 100,000Amp 2-stage surge and spike protection with dry contact status notification, refer to chart. The IsoCenter™ unit shall control all circuits via four 20A breakers in a load center located in the front panel and contain an LED indicator for input voltage monitoring status. Select models shall have two hardwired branch circuits, refer to chart. The monitoring circuits shall be equipped to shut down all outputs if the input voltage is compromised. When the input voltage returns back to normal operation the auto function shall restore the receptacles to a normal condition. The IsoCenter™ unit shall be provided with a 10' 30A power cord and a NEMA L6-30P twist-lock molded male plug. There shall be \_\_\_\_ (6,9) specification grade gray NEMA 5-20R 20 Amp duplex receptacles on the back of the unit for power distribution as well as a low impedance ground bus for rack enclosure grounding, connected equipment and local grounding electrical conductor. Unit shall measure 19"W x 7"H x 14.4"D and occupy 4 rackspace. Unit shall have a rear mounting range of 17.8" to 24.8". The IsoCenter™ shall weigh 105 lbs. net. IsoCenter™ unit shall be ETL Listed to UL standard 1012 in the US and to CAN/CSA C22.2#107.1 in Canada. The IsoCenter™ unit shall be GREENGUARD Gold Certified. The IsoCenter™ unit shall be RoHS EU Directive 2002/95/EC compliant. The IsoCenter™ unit shall be manufactured by an ISO 9001 and ISO 14001 registered company. The IsoCenter™ unit shall be warranted to be free from defects in material and workmanship under normal use and conditions for a period of 5 years.

Customizable specification clips available at [middleatlantic.com](http://middleatlantic.com)

EIA/TIA COMPLIANT



PRODUCT CERTIFIED FOR  
LOW CHEMICAL EMISSIONS  
UL.COM/GG  
UL 2818

US PATENT# 8, 542, 506

## standard specifications:

- 240 V 1Ø input model (ISOCTR-5R-240-NS / ISOCTR-5R-240-2)
- 208 V 1Ø input model (ISOCTR-5R-208-NS / ISOCTR-5R-208-2)
- Input power plug (NEMA L6-30P)
- Output power receptacles (NEMA 5-20R)
- 5KVA isolation transformer with an integrated Faraday shield to attenuate common-mode noise
- Optimized for high-frequency differential-mode noise attenuation
- Inaudible acoustical noise
- Dimensions: 19.00"W x 7.00"H x 14.4"D
- Rear rackrail mounting range- 17.9" to 24.9"
- Weight- 105 lbs net

what great systems are built on.™

A Group brand | legrand

Middle Atlantic Products

[middleatlantic.com](http://middleatlantic.com) | [middleatlantic.com](http://middleatlantic.com)

96-01118 / rev. 2g / 12-2-13

# IsoCenter™ Series

isolation transformer system

specifications continued:

## Master Power 2-Pole Circuit Breaker:

Switches the main power on and off to the primary side of the isolation transformer provides 25A at 208V (20A at 240) of over-current protection.

## Surge Protection:

100,000Amp 2-stage surge and spike protection with dry contact status notification, ISOCTR-5R-240/208-2 only.

## Load Center Breakers:

Provides four circuits of 20A over current protection to the designated banks of receptacles on the back of the unit.

## Status Indicators:

Voltage Range Monitor:

The voltage range monitor circuit will be incorporated to monitor the 240/208 Volt input. A green LED will illuminate to indicate that proper voltage is being applied to the transformer primary. A red LED will illuminate if the voltage is out of range (High or Low). This monitor LED function will operate when the main circuit breaker is in the "on" position. If the "out of voltage range" is detected a signal will be sent to the output power relay to disconnect the output power. Power on will automatically be re-initiated when the voltage is "in range." A delay circuit is incorporated to allow short, out of voltage range aberrations to be ignored.

Voltage Specs:

Operating Voltage 208V

Range: 181V to 232V (will shut down below 181V and start back up at 185V) (will shut down above 232V and start back up at 228V)

Operating Voltage 240V

Range: 210V to 266V (will shut down below 210V and start back up at 214V) (will shut down above 266V and start back up at 262V)

LED indicators Green=Within acceptable range, Red=Outside acceptable range

## External Ground / Bonding Bus:

An external ground bus is located at the rear of the unit in order to provide a termination point for establishing a low impedance single point grounding system (SPG) for the rack enclosure and connected equipment. This bus is a seven (7) position grounding terminal strip (screw type). Also a connection point for local grounding electrode conductor (if required by code).

## Transformer:

Includes a Toroidal isolation transformer, with a 98% high efficiency type with a proprietary alloy core, a single 120V secondary winding (all circuits on the same phase) with a Faraday shield.

## Chassis:

The IsoCenter™ system is housed in a rack mountable steel enclosure with a built in rear rail telescoping support. Overall dimensions: 7" high (4RU), 14.4" deep, 19" wide at the mounting ears and 17.5" wide at the chassis body, enclosure is black powder coat.

## Power In-feed:

Feeder circuit is pluggable. The unit is fed via a fixed molded "twist-lock" male plug (NEMA configuration L6-30P) and 10' long power cord. A 30A Single Phase feeder circuit is required.

## Power Output Receptacles:

The receptacle branch circuits are made up of eighteen (9 duplex) 20A specification grade gray receptacles, NEMA configuration is 5-20R. The receptacle labels are laser engraved indicating the circuit identification and bank arrangement.

## Remote Branch Circuit Extension:

Hardwire up to two remote branch circuits directly to unit, ISOCTR-5R-240/208-2 only.

## Maximum Load:

The maximum load shall not exceed 41.66A @ 120V (5000 Volt-Amperes) continuous. A de-rating factor of 80% may be required under certain conditions of installation and/or NEC Requirements.

## Controls:

All control circuits and relays are grouped onto two printed circuit boards with terminal strip connections for all wiring points

## Listings:

The IsoCenter unit shall be ETL Listed to UL standard 1012 in the US and to CAN/CSA C22.2#107.1 in Canada.

# IsoCenter™ Series

## basic dimensions

all dimensions in inches unless otherwise noted [all dimensions in brackets are in millimeters]

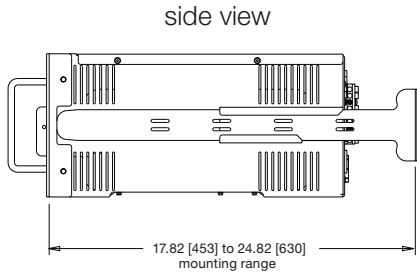
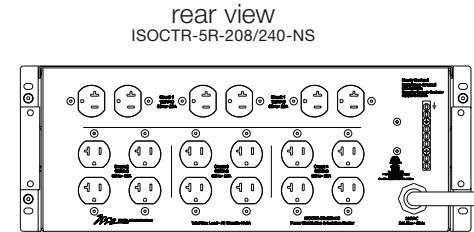
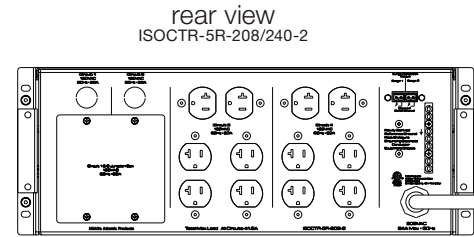
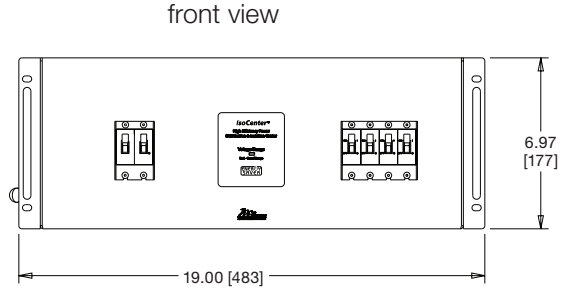
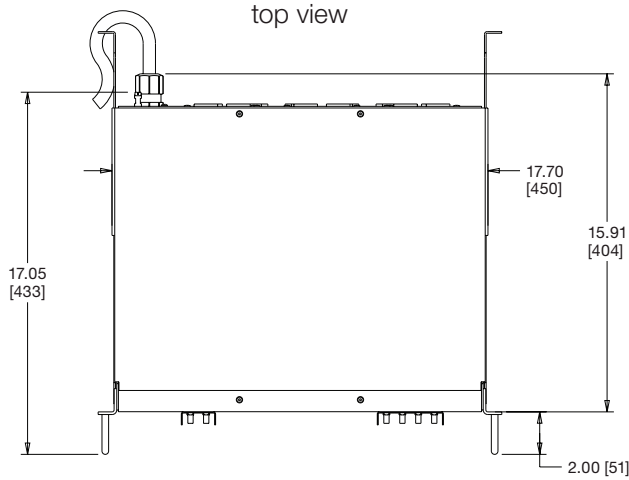

Part #	Description	Surge Protected	Remote Branch Circuit Expansion
ISOCTR-5R-240-NS	5kVA Rackmount Integrated Load Center - 240V 1Ø input	N/A	N/A
ISOCTR-5R-208-NS	5kVA Rackmount Integrated Load Center - 208V 1Ø input	N/A	N/A
ISOCTR-5R-240-2	5kVA Rackmount Integrated Load Center - 240V 1Ø input	100,000Amps	Yes
ISOCTR-5R-208-2	5kVA Rackmount Integrated Load Center - 208V 1Ø input	100,000Amps	Yes

what **great systems** are built on.™

A Group brand | **legrand**

**Middle Atlantic Products**  
middleatlantic.com | middleatlantic.ca