

WPP WEATHERPROOF SPEAKERPHONES

531 WPP WEATHERPROOF SPEAKERPHONES

Weatherproof cast aluminum housing with stainless steel panel

CEECO's WPP-531 Weatherproof Series speakerphones are designed for outside telecommunication applications that are directly effected by the weather and also serves as a rugged, lockable telephone for any indoor location. Our weatherproof telephones are constructed with a cast aluminum housing and high grade stainless steel telephone panel installed with tamper resistant hardware to deter vandalism and theft. The pushbutton acts as the hookswitch that initiates/disconnects calls and has an LED light that shows call progress by lighting red at off-hook, flashing red and green when dialing, and turning to a solid green when the called party has answered. The telephone will detect when the called party hangs up and will reset itself to the on-hook condition. The telephone can allow or not allow incoming calls and time calls if desired. The internal circuitry provides exceptional audio balancing and overall sound quality, as well as over-voltage protection to help guard against surging that might be generated by various conditions including storms. CEECO's WPP-531 Series telephones provide dependable weatherproof communication for your courtesy, emergency, or service applications and are built to last!



Made in the USA 

SPECIFICATIONS

| | |
|-----------------------------------|--|
| Mounting : | Weatherproof Housing 4 holes spaced 8" x 5 7/8" Also available pole mounting bracket |
| Environment: | Temperature: -30°C (-22°F) to 60°C (140°F) Humidity: 0%-90% non-condensating |
| Input Power: | Telephone Line Powered |
| Loop Current: | 30mA min to 80mA max |
| Impedance: | 600 ohms |
| Type Jack: | RJ11C |
| Ringer Equivalency: | 0.4A |
| UL & FCC Registration: | Certified |

FEATURES

Measurement: 12 5/8" H x 9 1/2" W x 8" D

Weight: 17lbs

Weatherproof, rugged design for indoor and outdoor environments

Available with keypad/dial, autodial, two button autodial, ring-down, or keypad/dial with autodial

Visibility options to include: steady on blue light, flashing strobe light, or Ring Strobe Light

Braille EMER emergency plate and red push button available on all models

WPP cast aluminum housing available in black, red, yellow or gray with TELEPHONE or EMERGENCY on the door

Analogue or VoIP, Line Powered

1 Year Warranty

Requires 301-064 Security Tool for Installation

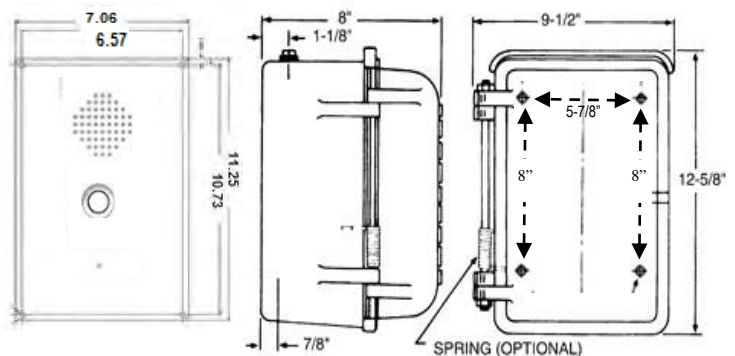

WPP-531/ 530 SPECS

CEECO has been providing telecom solutions since 1930. Our vandal resistant technology focuses on providing public communication solutions while reducing replacement and repair costs, lowering the customer's total cost of ownership. CEECO also offers custom design and branding to your specifications. Our commitment to providing expert service and support extends beyond the warranty of our product. We offer support for the life of the product! CEECO is devoted to giving you the quality and service you deserve.

WPP WEATHERPROOF SPEAKERPHONES

531 WPP WEATHERPROOF SPEAKERPHONES

Weatherproof cast aluminum housing with stainless steel panel

| KEYPAD WEATHERPROOF SPEAKERPHONES | AUTO DIAL WEATHERPROOF SPEAKERPHONES | RING-DOWN WEATHERPROOF SPEAKERPHONES |
|--|---|--|
| <p>WPP-531-F-G WPP-531-FD-ADA-SP</p> | <p>WPP-531-D-ADA-Y WPP-531-DD-ADA-R</p> | <p>WPP-531-X-ADA-Y WPP-531-X-ADA-R-ST</p> |
| <p>Dimensions: 12 5/8" H x 9 1/2" W x 8" D</p> | <p>Dimensions: 12 5/8" H x 9 1/2" W x 8" D</p> | <p>Dimensions: 12 5/8" H x 9 1/2" W x 8" D</p> |
| <p>Weatherproof Cast Aluminum Housing with Stainless Steel Panel</p> <p>Puncture and Weatherproof Speaker</p> <p>Press to Start/ Press to Stop Button</p> <p>WPP-531-F Model Chrome Tone Dial Keypad (F)</p> <ul style="list-style-type: none"> Ability to allow or block incoming calls Call restriction capability Programmable conversation time-out Optional speed dialing Programmable PBX prefix dialing or access number <p>WPP-531-FD Model Chrome Tone Dial Keypad (F) and a Auto Dial Push Button (D)</p> <ul style="list-style-type: none"> Ability to allow or block incoming calls Call restriction capability Programmable conversation time-out Optional speed dialing Programmable PBX prefix dialing or access number | <p>Weatherproof Cast Aluminum Housing with Stainless Steel Panel</p> <p>Puncture and Weatherproof Speaker</p> <p>Press to Start/ Press to Stop Button</p> <p>WPP-531-D Model Auto Dial Push Button (D)</p> <ul style="list-style-type: none"> Ability to allow or block incoming calls Programmable conversation time-out capability Programmable PBX prefix dialing or access number <p>WPP-531-D2 Model Auto Dial Push Button (D2)</p> <ul style="list-style-type: none"> Will dial a second number if called party doesn't answer first number dialed <p>WPP-531-DD Model Auto Dial Push Button (DD)</p> <ul style="list-style-type: none"> Two programmable auto dial buttons Ability to allow or block incoming calls Programmable conversation time-out capability | <p>Weatherproof Cast Aluminum Housing with Stainless Steel Panel</p> <p>Puncture and Weatherproof Speaker</p> <p>Press to Start/ Press to Stop Button</p> <p>WPP-531-X Model Ring-down Operation (X)</p> <ul style="list-style-type: none"> Ability to allow or block incoming calls Initiate a call when programmed through a PBX or phone system |
| | | LOW POWER MODELS |
| | | <p>WPP-530-F, WPP-530-D, WPP-530-X</p> <ul style="list-style-type: none"> Full Function ADA features are NOT available |

ADDITIONAL OPTIONS IP - Voice over Internet Protocol Version available on all models (SIP)

| -ADA | Weatherproof Housing | -ST/-SB/-RST | -RIL | -SP | Pole Mount | Additional Options & Features |
|---|--|--|--|----------------------------------|--|---|
| | | | | | | <p>Auto Answer (AA) Remote Programming (RP) Voice Announcement (VA)</p> |
| <ul style="list-style-type: none"> Red/ green LED call progress indicator light Braille Emergency Plate "EMERG. PHONE" Red push button | <p>Standard Black & TELEPHONE on Door</p> <p>-B-EMER Black & EMERGENCY on Door</p> <p>-R Red & EMERGENCY on Door</p> <p>-R-TEL Red & TELEPHONE on Door</p> <p>-Y Yellow & EMERGENCY on Door</p> <p>-Y-TEL Yellow & Telephone on Door</p> <p>-G Grey & TELEPHONE on Door</p> <p>-G-EMER Grey & EMERGENCY on Door</p> | <p>Blue Strobe Light option:</p> <ul style="list-style-type: none"> Steady on Flashing For location visibility Requires AC power | <p>Ring Indicator Light located on the phone panel for visual ring indication.</p> | <p>Spring loaded door option</p> | <p>Pole Mounting bracket fits poles 2.5" - 6".</p> | |

Visit our website at www.ceeco.net or call us at 863-357-0798 for detail specifications on any of our models.