



***READ ALL OF THE FOLLOWING INSTRUCTIONS BEFORE
REMOVING **CABINET** FROM SKID***

NET-ACCESS S-Type Server Cabinets

TOOL LIST

- | | |
|------------------------|--------------------|
| -Phillips screwdriver | -7mm socket wrench |
| -Flatblade screwdriver | -T30 Torx bit |
| -22mm socket wrench | -T25 Torx bit |
| -15mm socket wrench | -6mm Allen key |
| -13mm socket wrench | -2.5mm Allen key |
| -8mm socket wrench | -Wire cutter |

PANDUIT *NET-ACCESS S-Type Server Cabinets* (Server Configurations)

INSTRUCTIONS CM599E

© Panduit Corp. 2013

NOTE - Some views in this document may vary slightly from your actual cabinet configuration.



FOR TECHNICAL SUPPORT www.panduit.com/resources/install_maintain.asp

Table of Contents - Net-Access S-Type Server Cabinets

General Cabinet Operation	Page
Packaging Material Removal.....	4
Leveling.....	5
Floor Mounting.....	6
Ganging.....	7-8
Grounding.....	9
Equipment Rail Adjustment.....	10
Overhead Cable Openings.....	11
Cable Management Fingers Installation (SN15F, SN25F).....	12
Single Hinge Door (<i>Removal and Installation</i>)	13-14
Rear Split Doors (<i>Removal and Installation</i>)	15
Side Panels (<i>Distinguishing Features</i>)	16
Side Panels (<i>Removal/Installation and Adjustment - optional</i>)	17
PDU Bracket Adjustment.....	18
Cabinet Sealing.....	19
Front and Back Floor Seals (<i>for vertical exhaust ducts</i>)	20
Top of Cabinet Cable Manager Installation.....	21
Top of Cabinet Cable Manager Installation (<i>for vertical exhaust ducts</i>)	22

Note: The maximum static weight load of the cabinet is 3000 lbs. [1361 kg]. The maximum weight load when the cabinet is rolling on casters is 2500 lbs. [1134 kg]. The weight load should be evenly distributed across the height of the cabinet, with the heaviest components mounted at the bottom of the cabinet.

Packaging Material Removal

Before removal of packaging material:

Check tip indicator on the outside of cabinet to ensure cabinet was shipped in the upright position. If tip indicator shows improper handling, inspect cabinet for damage before accepting cabinet.

Before handling cabinet:

Small glide strips are installed at various locations around the cabinet to protect the cabinet's finish during shipping. These strips are to be removed prior to handling of cabinet.

“Shipping Hold Down Bracket” Doubles as Floor Mounting Bracket. Retain bracket if floor mounting is desired. (see Page 6)

- Remove all stretchwrap and protective cardboard from outside of cabinet
- Remove all Shipping Brackets (if necessary)
- Remove [2] Hold Down Brackets at front and rear of cabinet
- Use [2] people to carefully lift and remove cabinet from pallet

IMPORTANT:

Leveling Legs must be fully retracted before the cabinet is moved into place. Sliding cabinet on leveling legs may result in damage to the leveling legs. (Leveling Legs ship in retracted position)

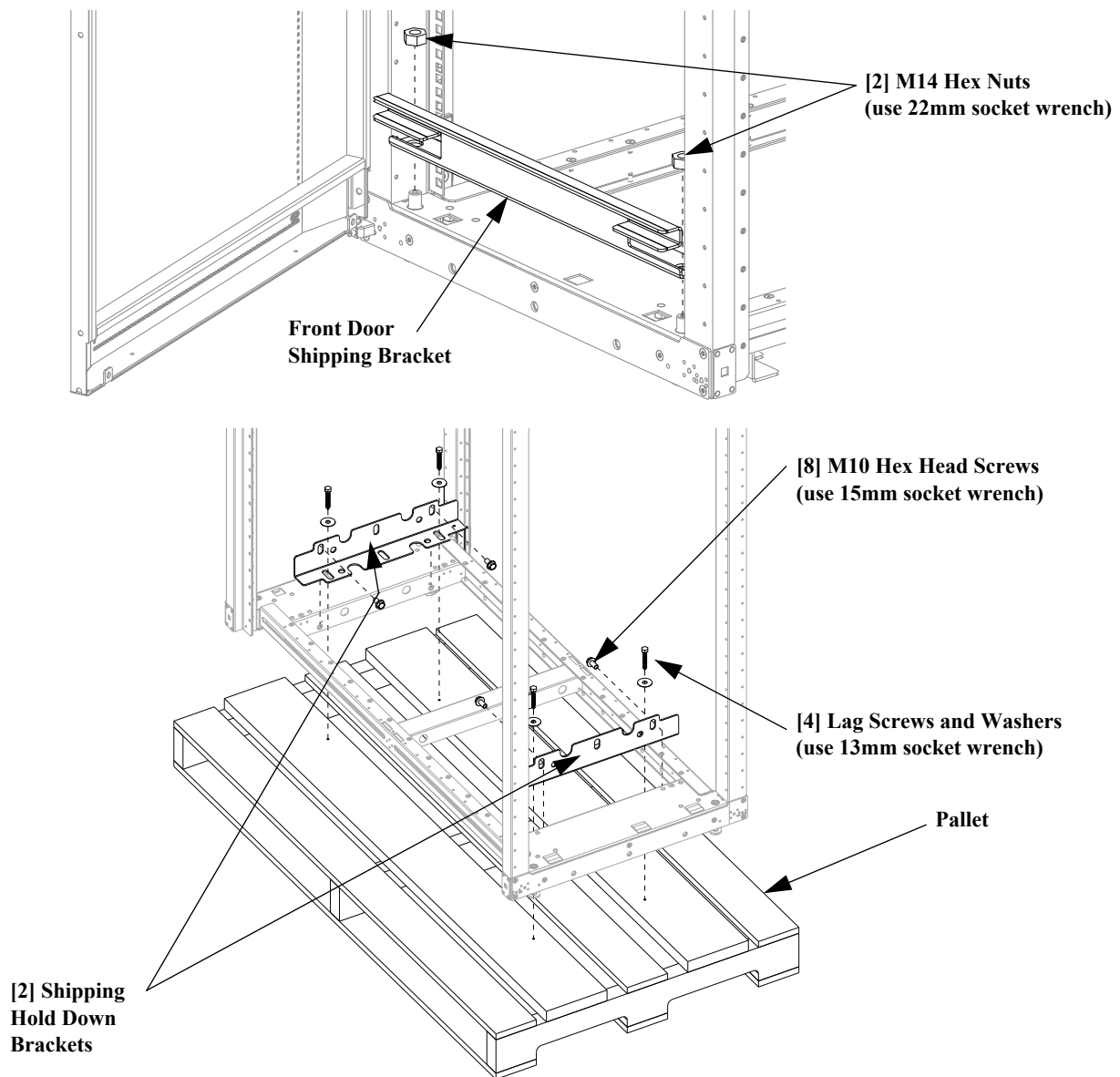

Note: Doors, Side panels, and other components are removed for clarity.

Leveling

- Ensure that [4] Leveling Legs are fully retracted
- Slide Cabinet into final position
- Lower the [4] Leveling Legs until the cabinet weight is fully supported by only the leveling legs
- Adjust the [4] Leveling Legs so that the cabinet is level front-to-back and side-to-side

Front-to-Back Cabinet Leveling

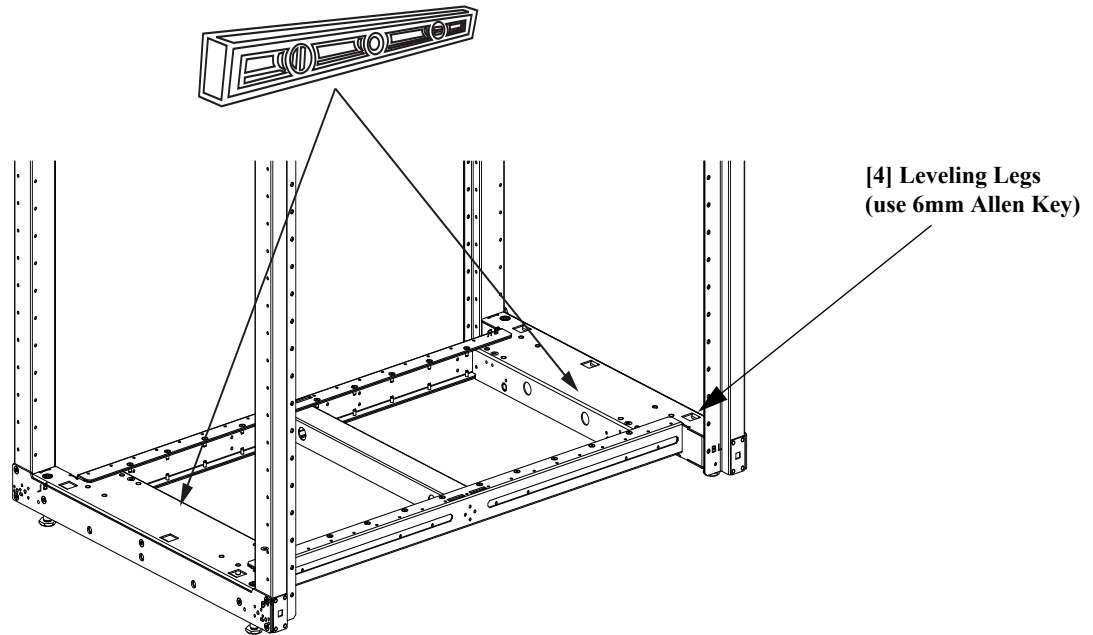

Side-to-Side Cabinet Leveling

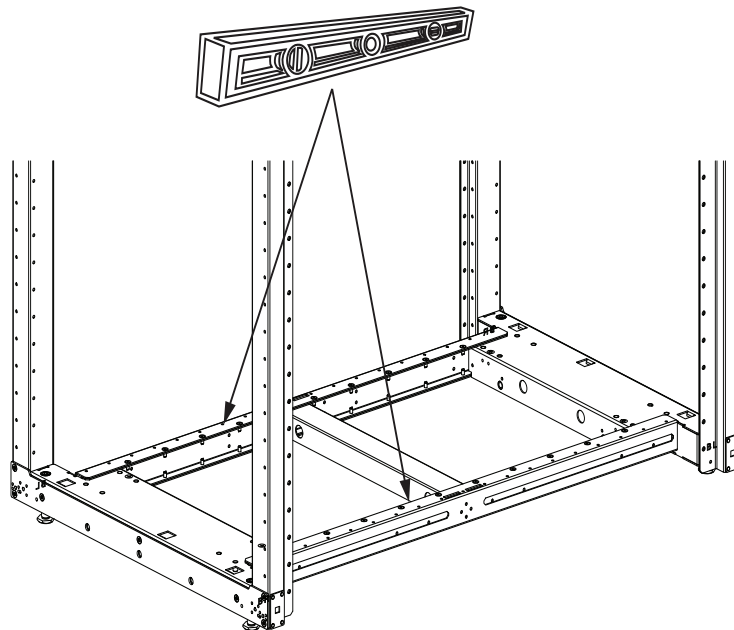

Note: When ganging multiple cabinets together, ensure that adjacent cabinets are adjusted to the same height.

Floor Mounting

- Ensure that [4] Leveling Legs are fully retracted
- If Necessary, secure [2] “Shipping Hold Down Brackets” at front and rear of cabinet
- See Floor Mounting View below for floor mounting dimensions
- Attach the anchors to the floor with appropriate hardware for your type of floor

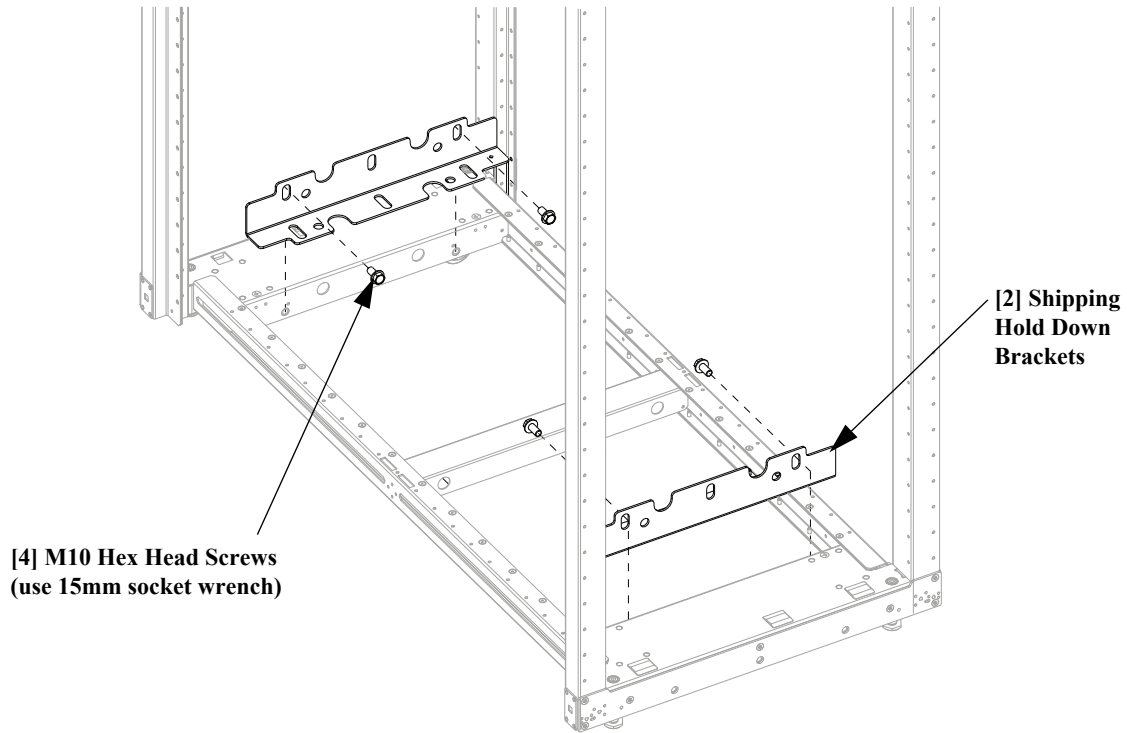

Floor Mounting View

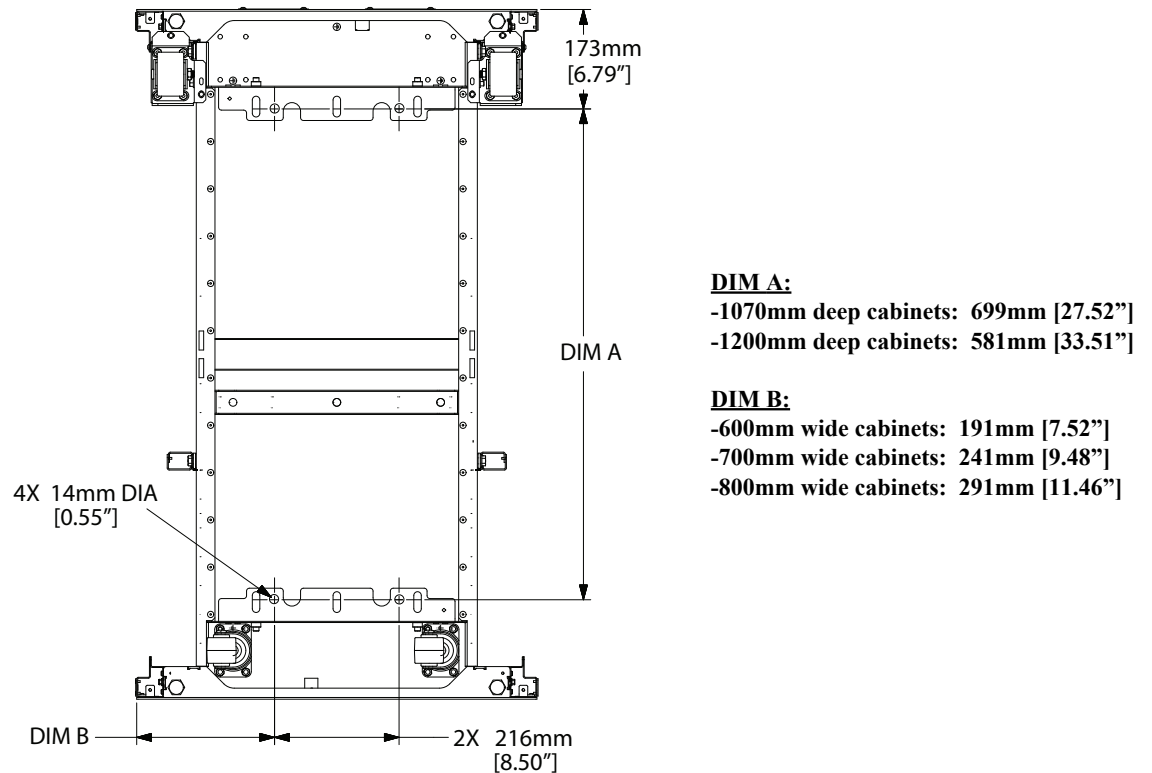

Ganging (front of cabinet)

- Ensure cabinets are level
- Secure Ganging Brackets to cabinets at [2] front locations shown below
- Do not use Ganging Brackets to cinch cabinets together

IMPORTANT:

Ensure cabinets are level by following the guidelines on page 5. Leveling the cabinet prior to ganging is important to ensure proper door operation.

[2] Front Ganging Brackets

[4] M6 Torx Screws
(use T25 Torx bit)

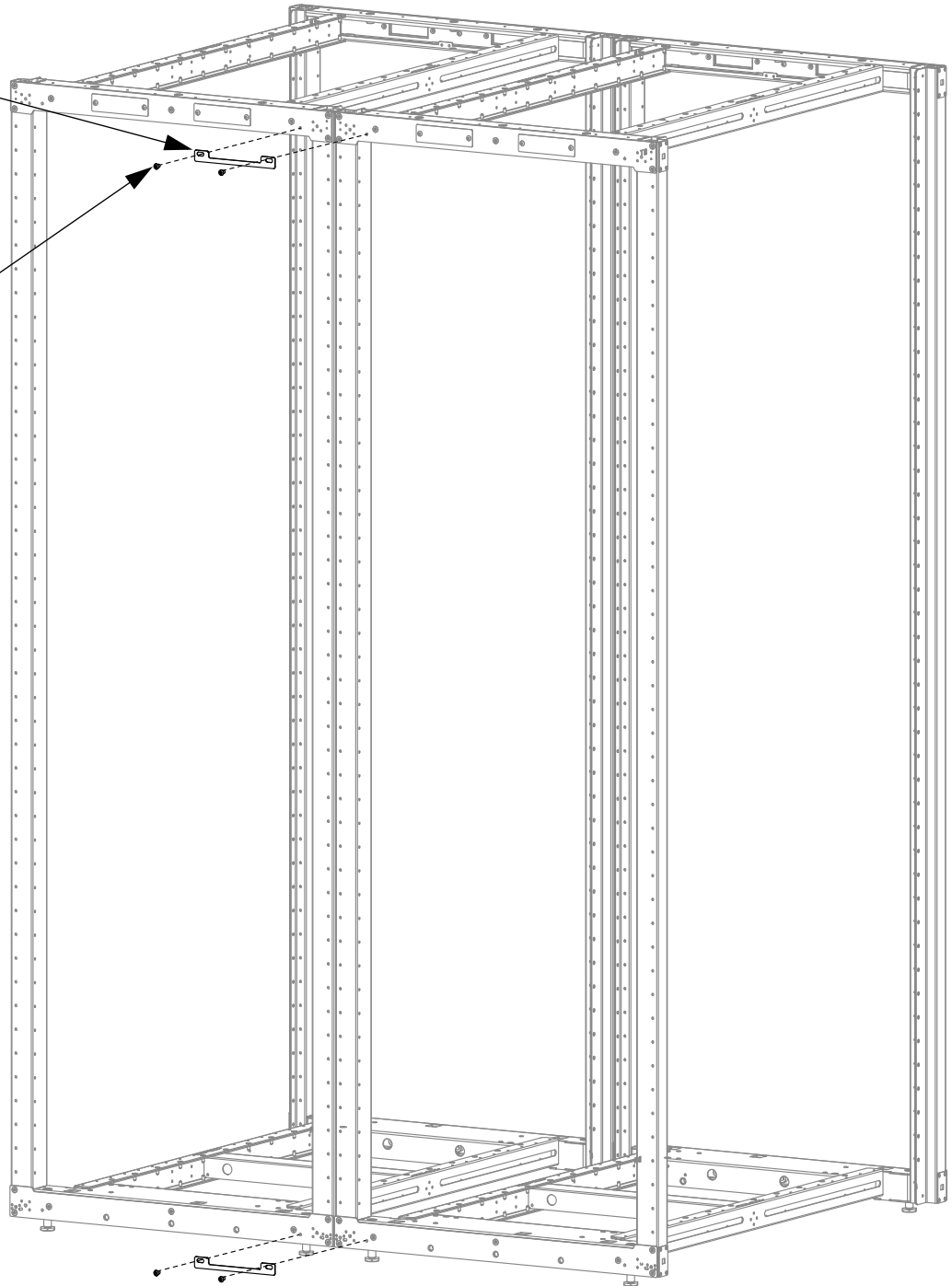

FRONT OF CABINETS

Ganging (rear of cabinet)

- Ensure cabinets are level
- Secure Ganging Brackets to cabinets at [2] rear locations shown below
- Do not use Ganging Brackets to cinch cabinets together

IMPORTANT:

Ensure cabinets are level by following the guidelines on page 5. Leveling the cabinet prior to ganging is important to ensure proper door operation.

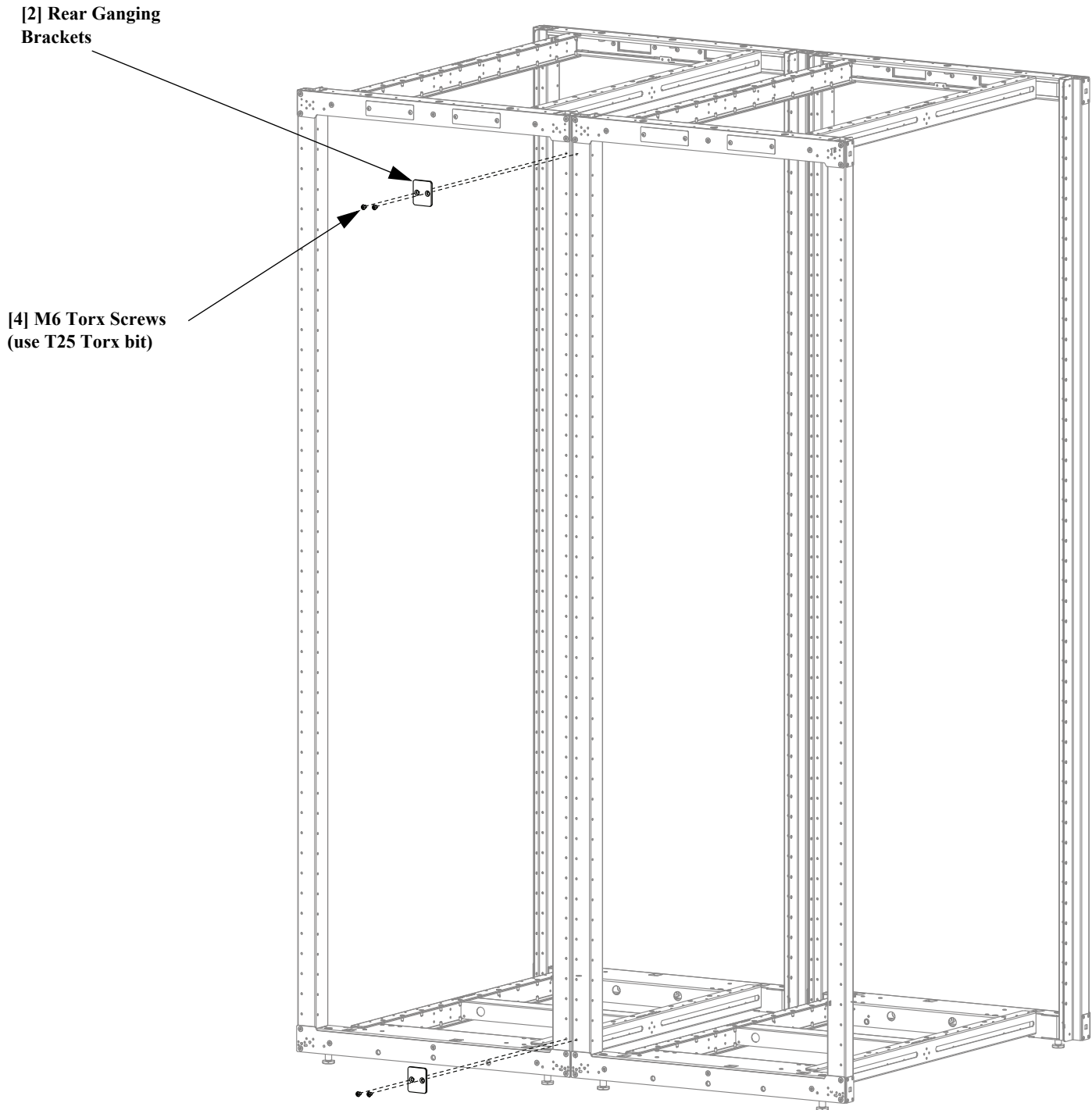

REAR OF CABINETS

Grounding

- Attach Grounding Lug or Grounding Bar at any of the [6] location(s) shown below
- Grounding location is indicated by universal ground symbol
- Use M5 bonding screw

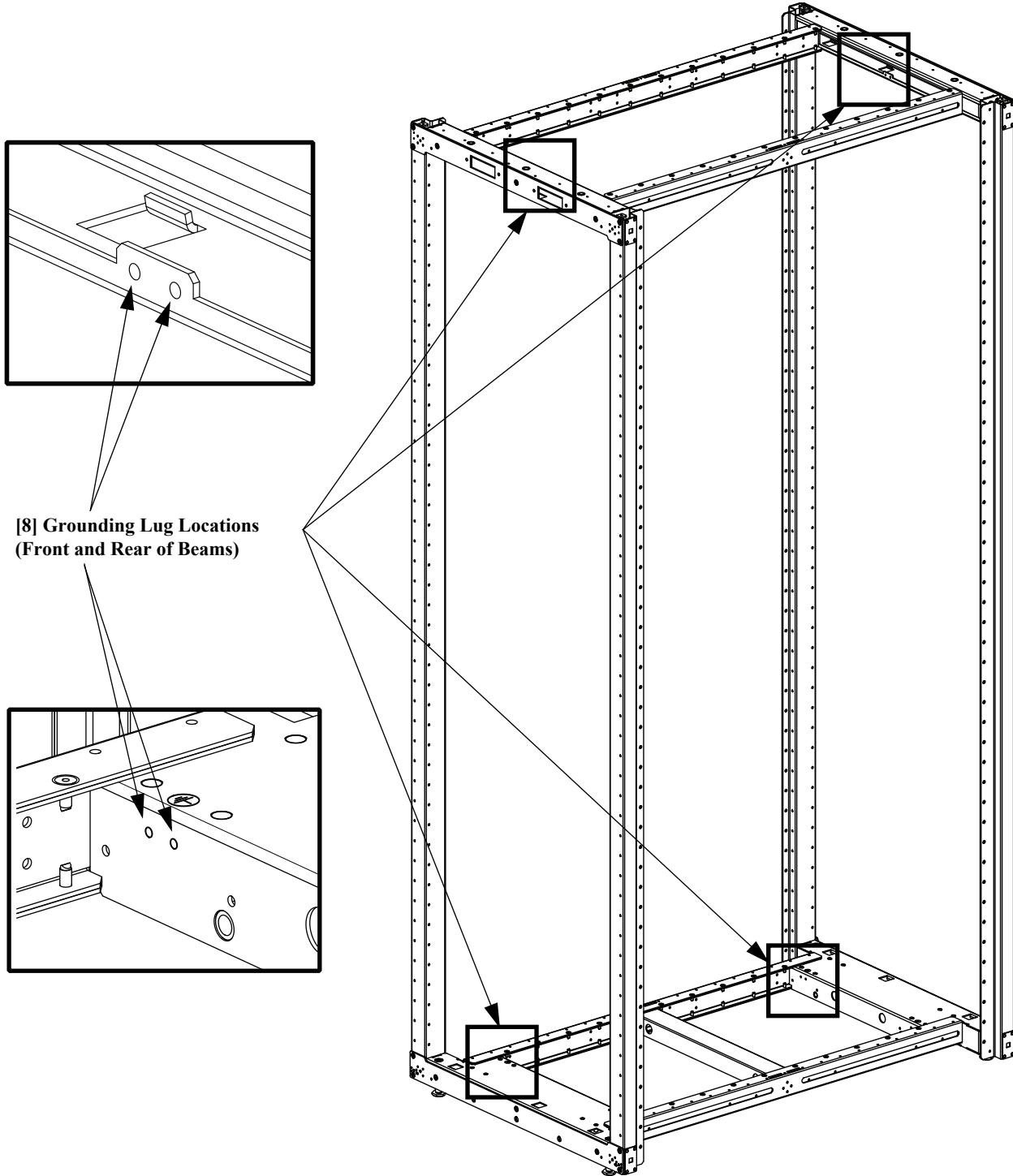

Note: top cap removed for clarity.

Equipment Rail Adjustment

- Loosen M10 Hex Head Screw at top and bottom of rear equipment rail
- Adjust equipment rail to desired position
- Tighten M10 Hex Head Screw to 30.0 +/- 5.0 N-m [22.1 +/- 3.7 Ft-lbs]

NOTE: Front equipment rails are in a fixed position

Uninstall/Re-install and Move Equipment Rails (Top and Bottom Locations)

- Remove [2] M10 Hex Screws at top and bottom of Equipment Rail
- Remove [2] Equipment Rail Mount Nuts through slots of Front-to-Back Beam
- REVERSE STEPS to re-install Equipment Rails (insert Equipment Rail Mount Nuts through slots of Front-to-Back beam while holding finger grip of mount nut; ensure that barbed surface of Equipment Rail Mount Nut faces outside of cabinet)

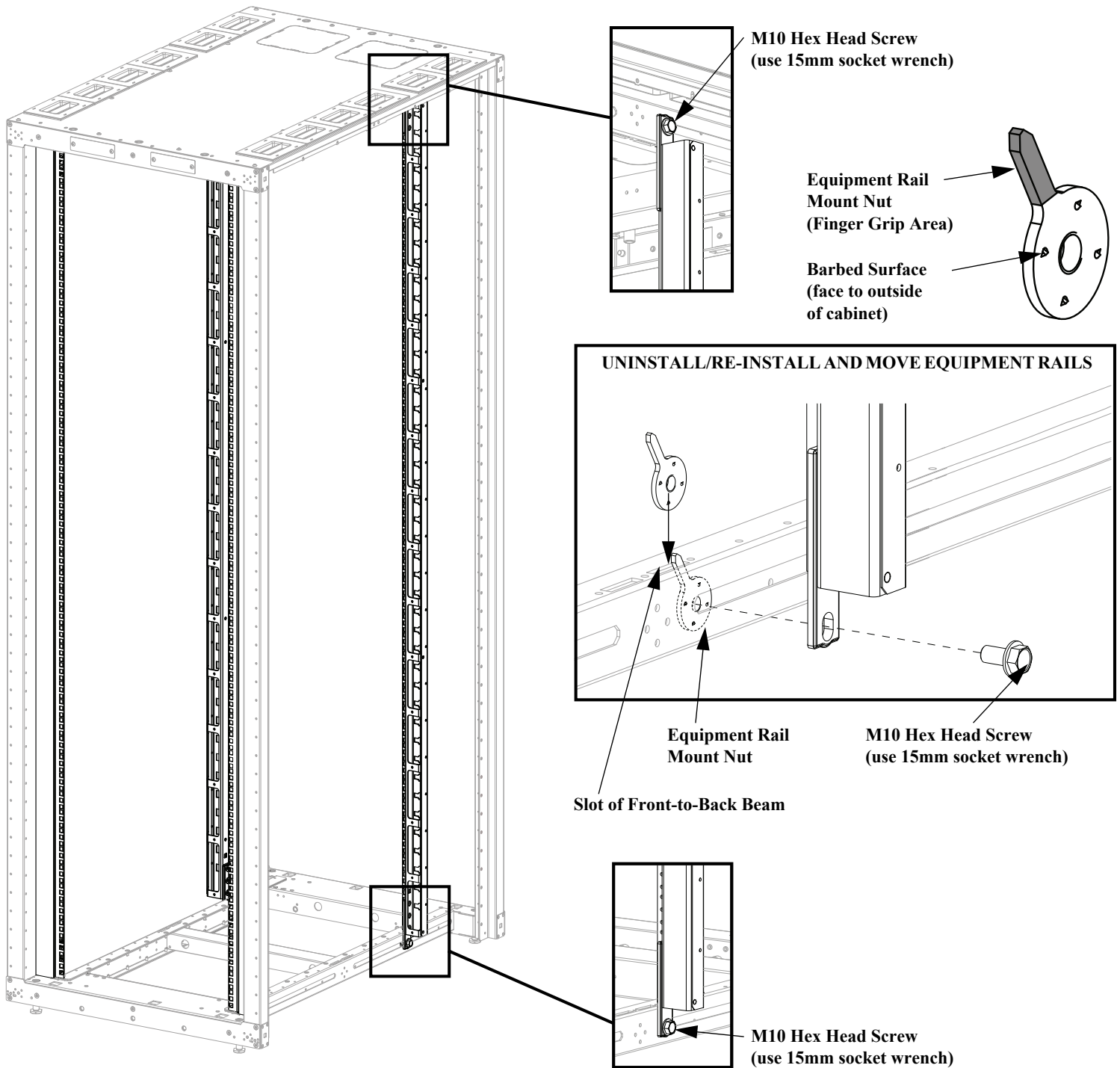

Overhead Cable Openings

- Remove Bezel Insert to allow for overhead cable entry
- Cut [8] tabs with wire cutter to open large cable openings - OPTIONAL
- Install M10 threaded rod into [6] tapped holes, if desired
- [2] 152.4mm x 152.4mm [6" x 6"] openings can be used to route power overhead
- PANDUIT COOL BOOT™ products can be used to seal around cables/fiber to prevent hot air recirculation

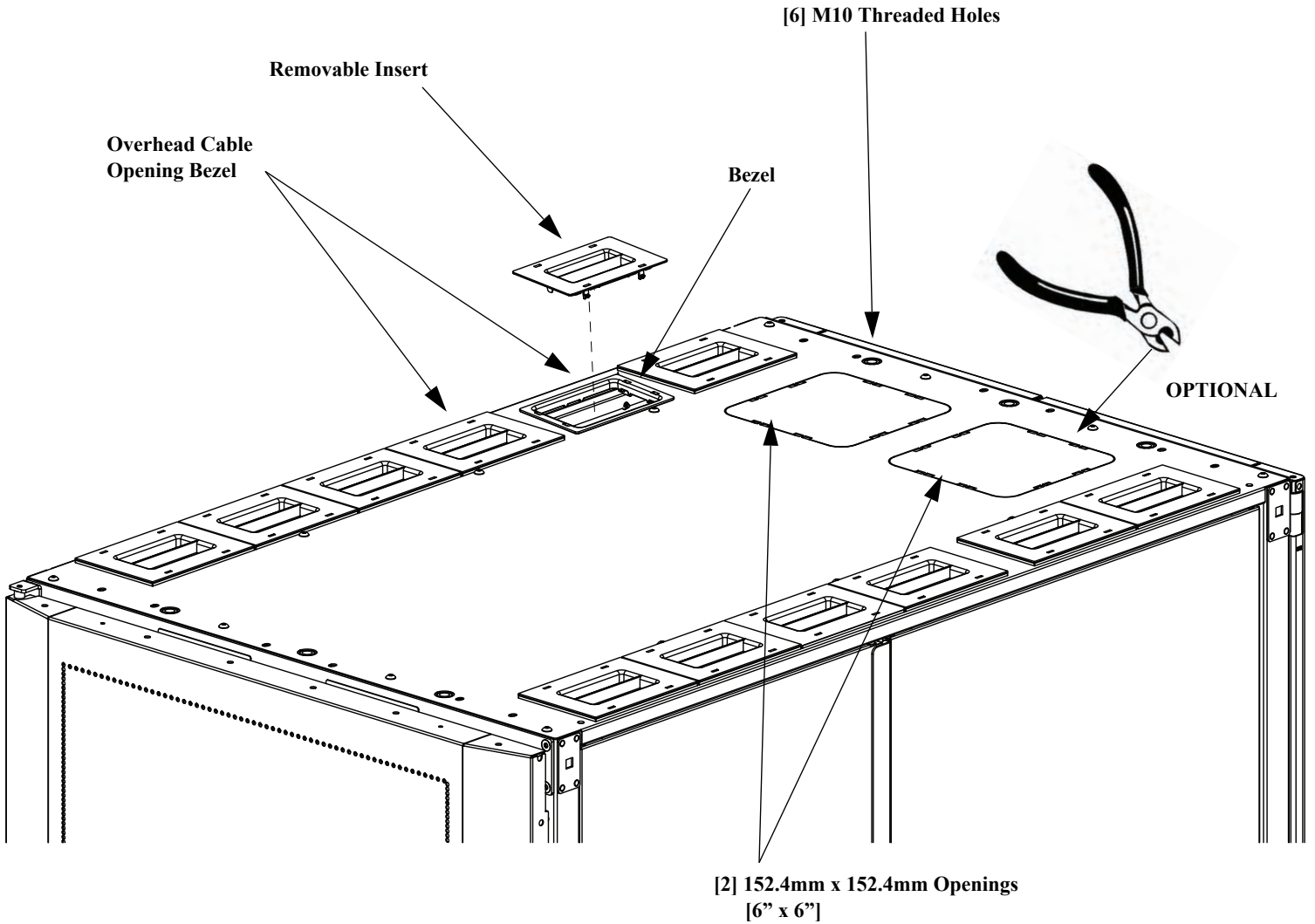

Cable Management Fingers (SN15F, SN25F)

- Insert tabs of Cable Management Finger into mounting slots of cabinet post
- Slide Cable Management Finger inward to lock into place

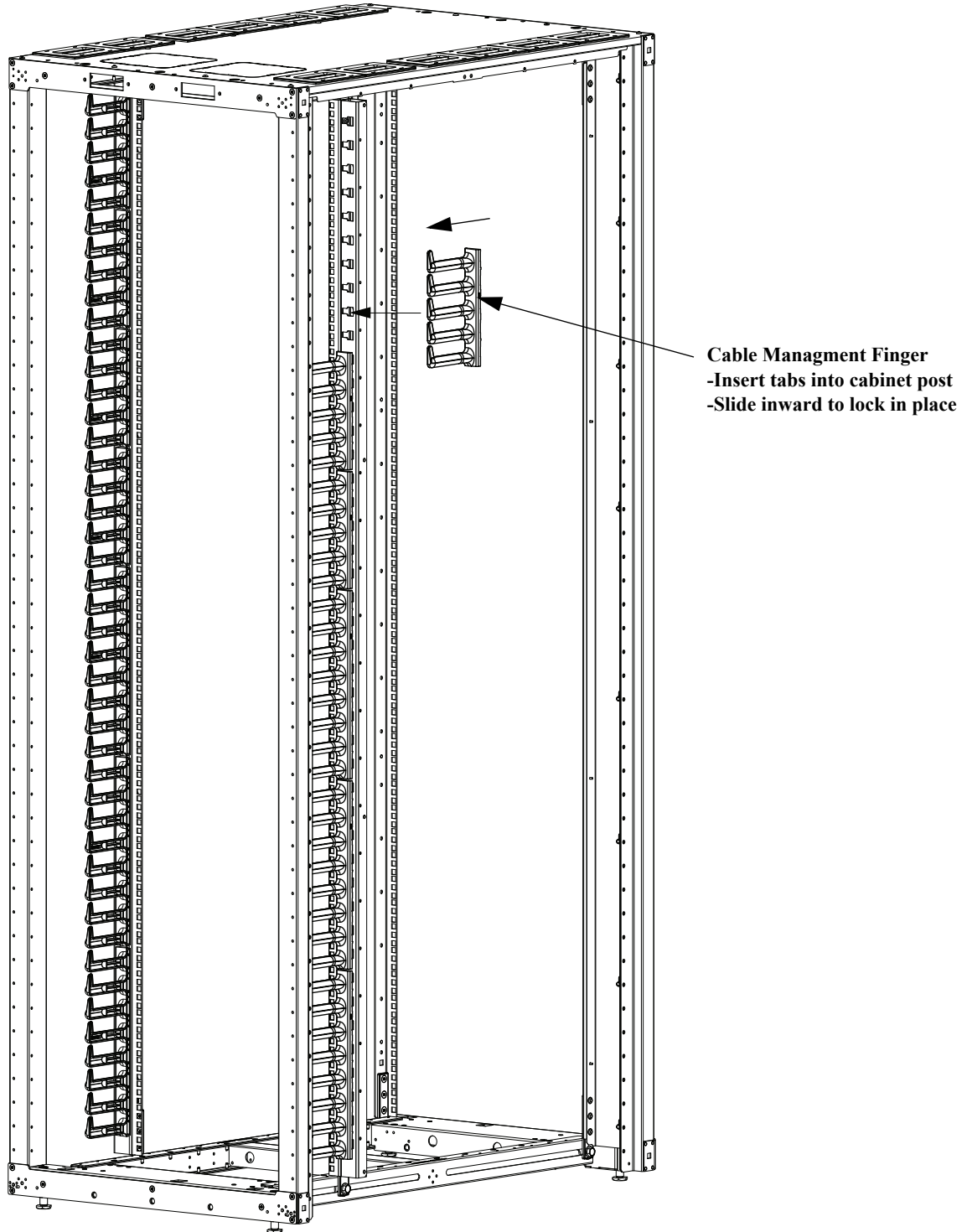

Single Hinge Door (Removal and Installation)

- VIEW 1 Pull down Compression Sleeve at top door hinge
- VIEW 1 Pull Single Hinge Door away from cabinet so that Top Hinge Screw fits through cutout of door
- VIEW 2 Lift bottom of door off Bottom Hinge Pin
- REVERSE STEPS to install Single Hinge Door

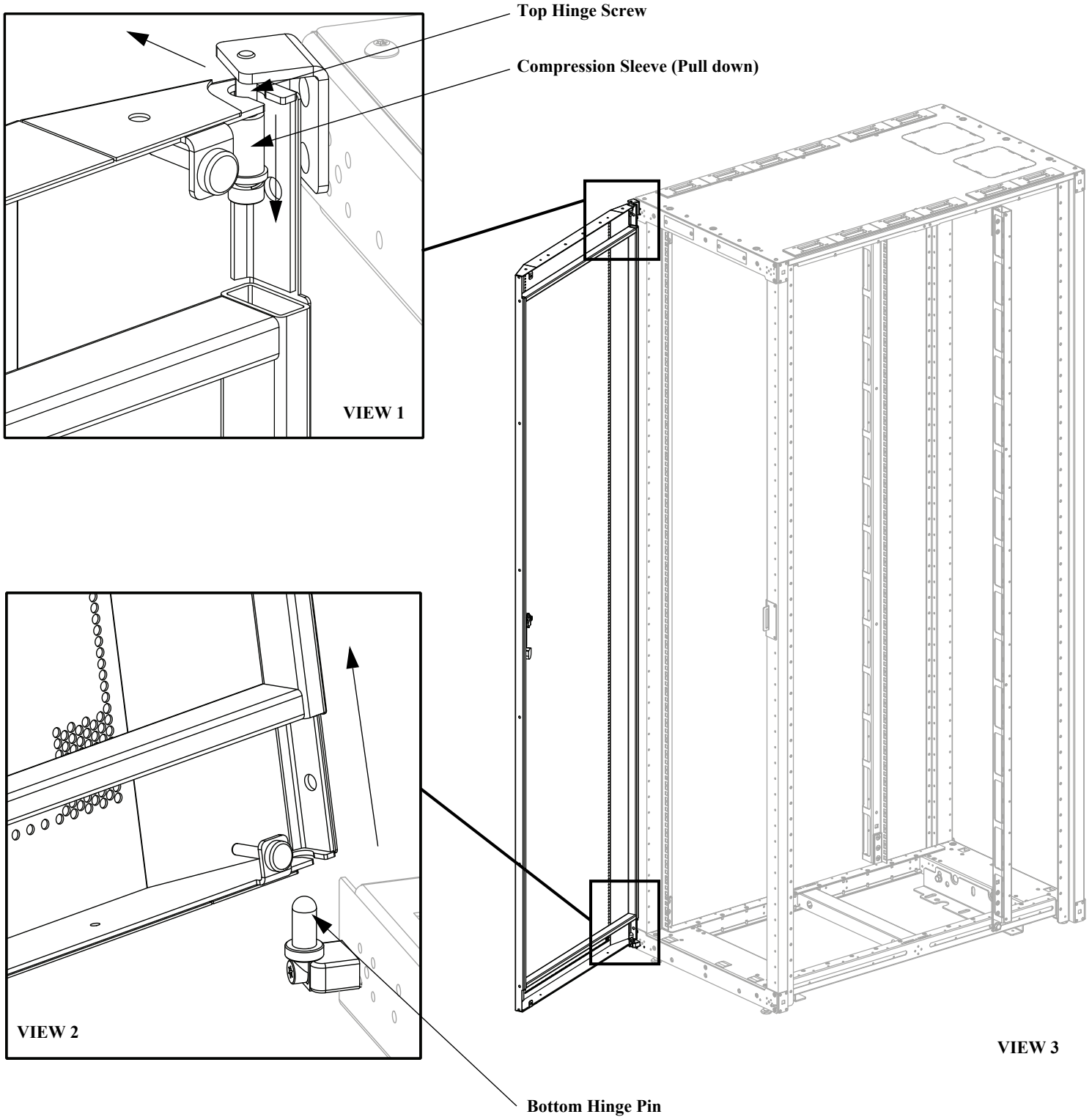

Single Hinge Door (Door Handle Direction Reversal)

- VIEW 1, 2 Remove Top and Bottom Hinge Brackets from current location (remove top hinge screw, if necessary)
- VIEW 1, 2 Install Top and Bottom Hinge Brackets on opposite side of cabinet (re-install top hinge screw, if necessary)
- VIEW 3 Move Door catch to opposite side of cabinet frame

Door Handle Reversal (Lay door on a flat surface) - VIEW 4, 5

- Remove Door Handle Backing Plate and rotate position of Door Handle 180°
- Loosen Cam Screw to reposition Door Cam and Cam Stop to outside of door. Tighten Cam Screw
- With Door Handle repositioned, secure Door Handle Backing Plate to Door Handle
- Remove PANDUIT label and re-attach in correct orientation near top of door
- Reinstall Single Hinge Door per instructions on Page 12

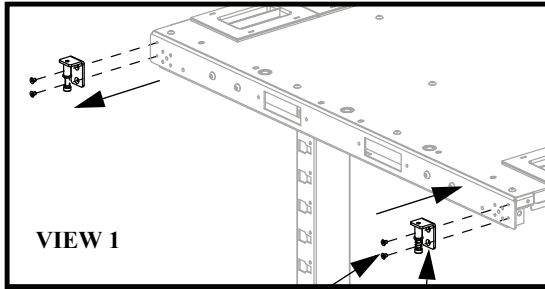

[2] M4 Screws
(use 2.5mm Allen Key)

Top Hinge Bracket

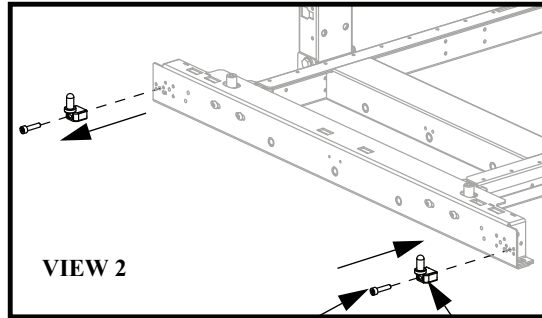

M6 Torx Screw
(use T30 Torx bit)

Bottom Hinge Bracket

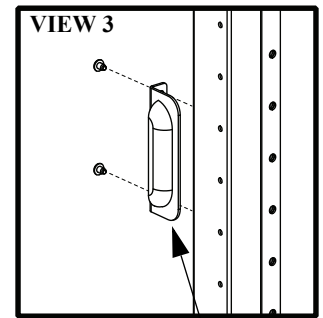

Door Catch

[2] Hex Nuts
(use 8mm socket wrench)

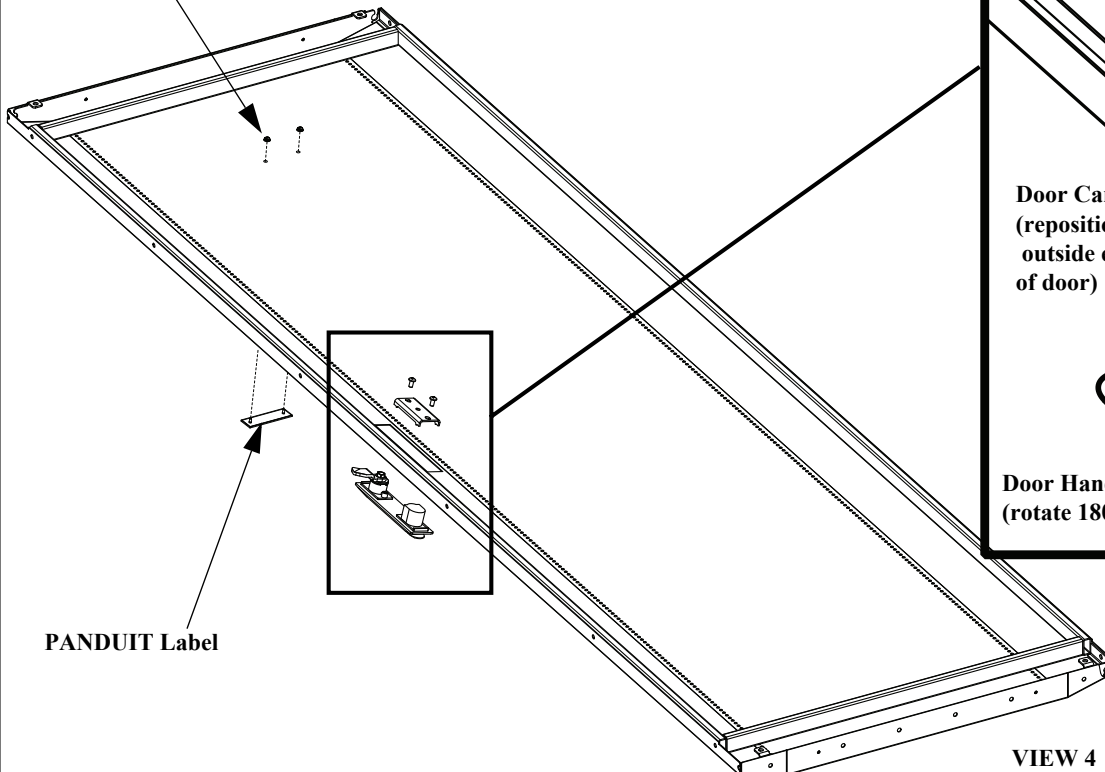

PANDUIT Label

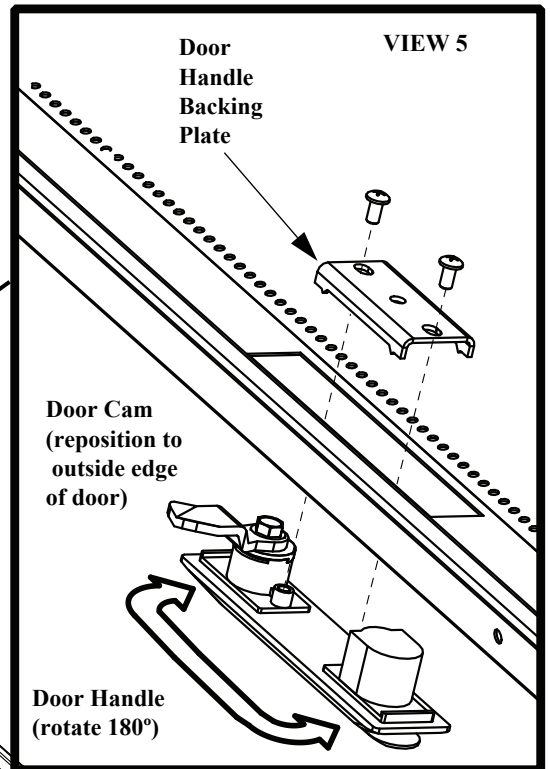

Door Handle Backing Plate

Door Cam
(reposition to outside edge of door)

Door Handle
(rotate 180°)

VIEW 4

Rear Split Doors (Removal and Installation)

- Open Rear Split Doors to approximately 90°
- Lift Rear Split Doors up pull doors away from cabinet frame
- REVERSE STEPS to install Rear Split Doors

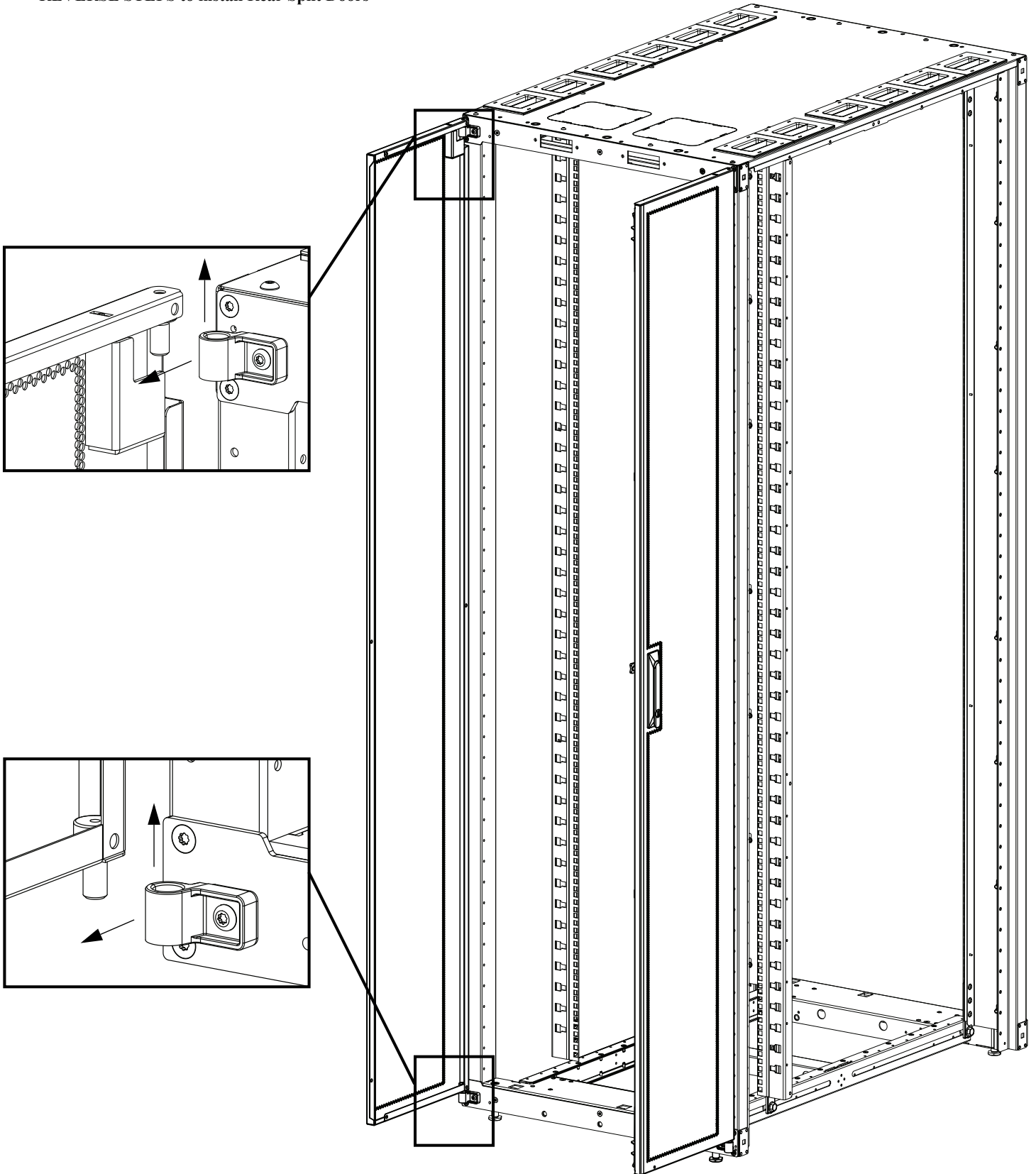

For Technical Support: www.panduit.com/resources/install_maintain.asp

Side Panel - (Distinguishing Features -- also reference instructions V00029CM)

Original Cabinet

MUST USE THESE PART NUMBERS: S21SPS, S22SPS, S51SPS, S52SPS
S81SPS, S82SPS, S11SPS, S12SPS

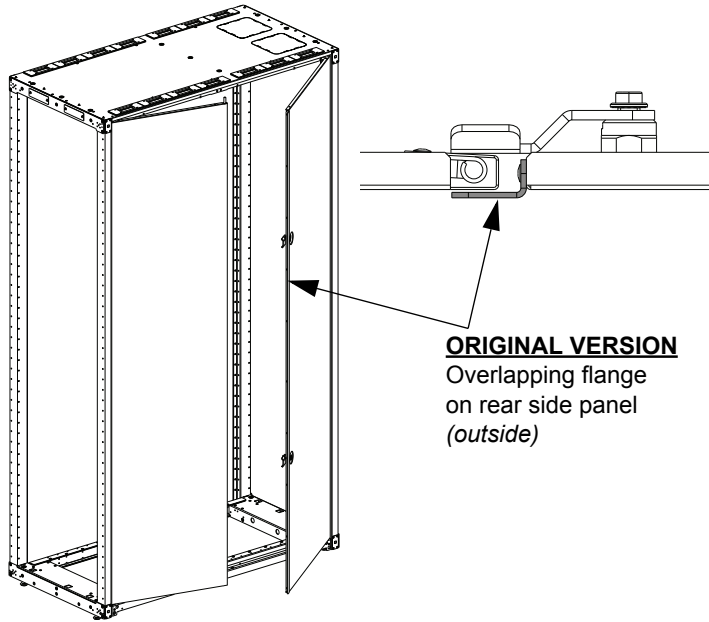

ORIGINAL VERSION
Overlapping flange
on rear side panel
(outside)

Current Cabinet

MUST USE THESE PART NUMBERS: S21SPSE, S22SPSE, S51SPSE, S52SPSE
S81SPSE, S82SPSE, S11SPSE, S12SPSE

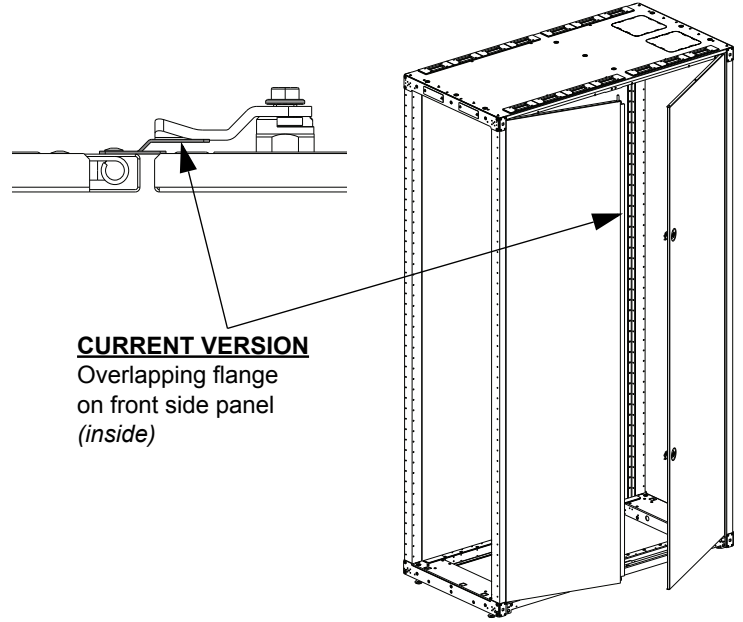

CURRENT VERSION
Overlapping flange
on front side panel
(inside)

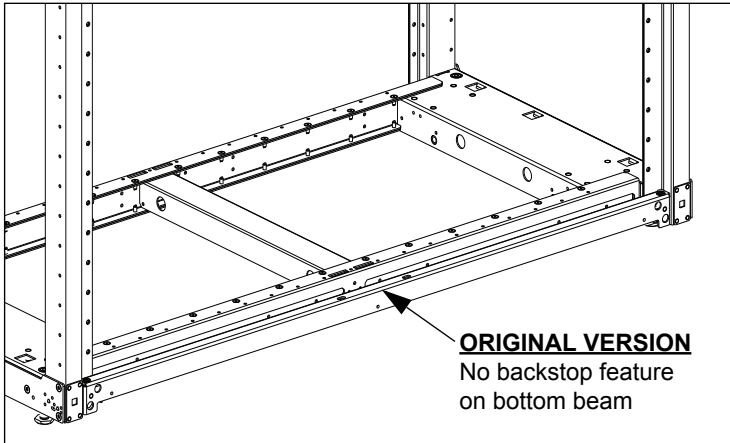

ORIGINAL VERSION
No backstop feature
on bottom beam

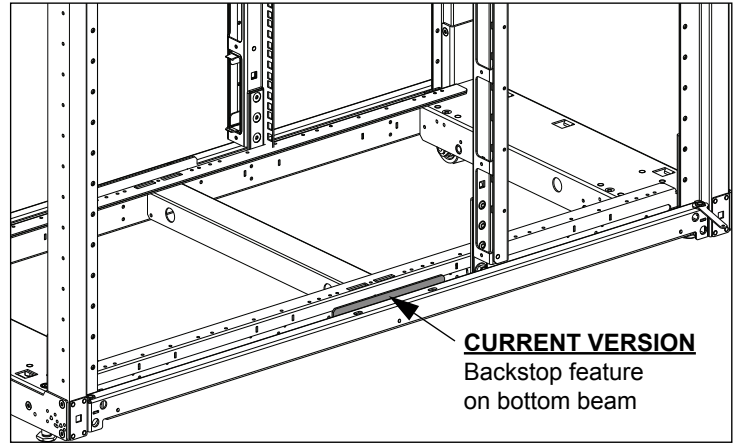

CURRENT VERSION
Backstop feature
on bottom beam

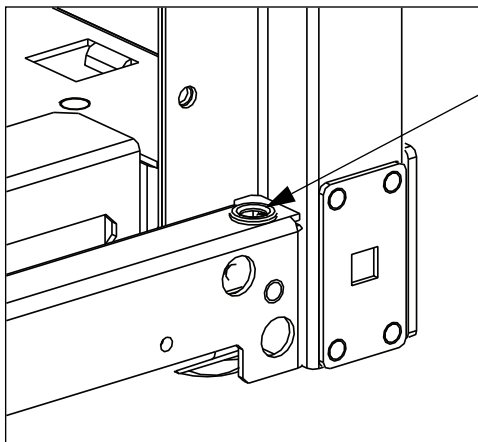

ORIGINAL VERSION
[2] Plastic
bushings

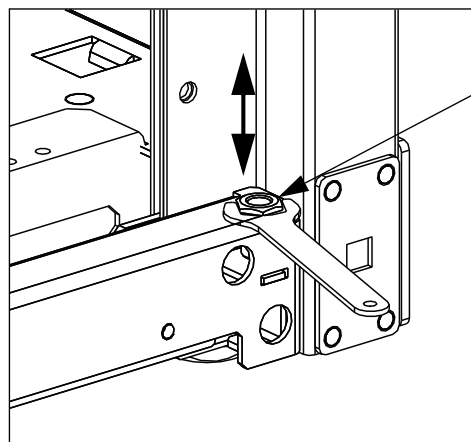

CURRENT VERSION
[2] Adjustable
bushings

Side Panels (Removal/Installation and Adjustment - optional)

- Pull [2] Spring Loaded Hinge Pins to release Rear Side Panel from cabinet frame
 - Pull [4] Spring Loaded Hinge Pins to release Front Side Panel from cabinet frame
 - REVERSE STEPS to install In-Row Side Panels
- IMPORTANT:** Install Front Side Panel First

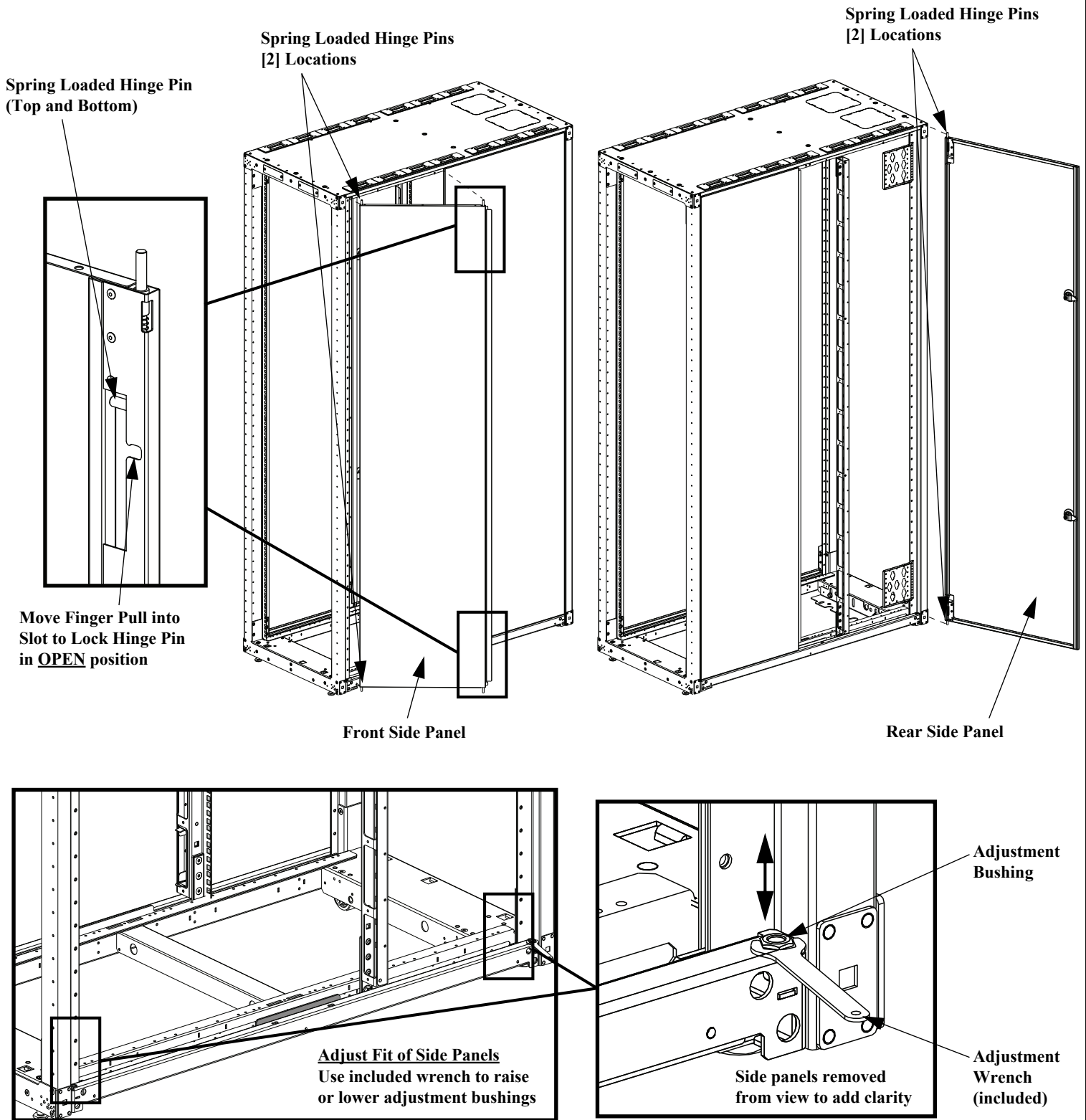

PDU Bracket Adjustment

- PDU brackets are height-adjustable if PDU spacing other than the factory position is desired.
- Remove [2] M5 Torx Screws per bracket, as shown below
- Reposition brackets at desired distance, ensuring that mounting flange of PDU bracket rests on the outside of cabinet post. (See 'Installed' view below)
- Secure each PDU bracket to cabinet post with [2] M5 Torx Screws per bracket

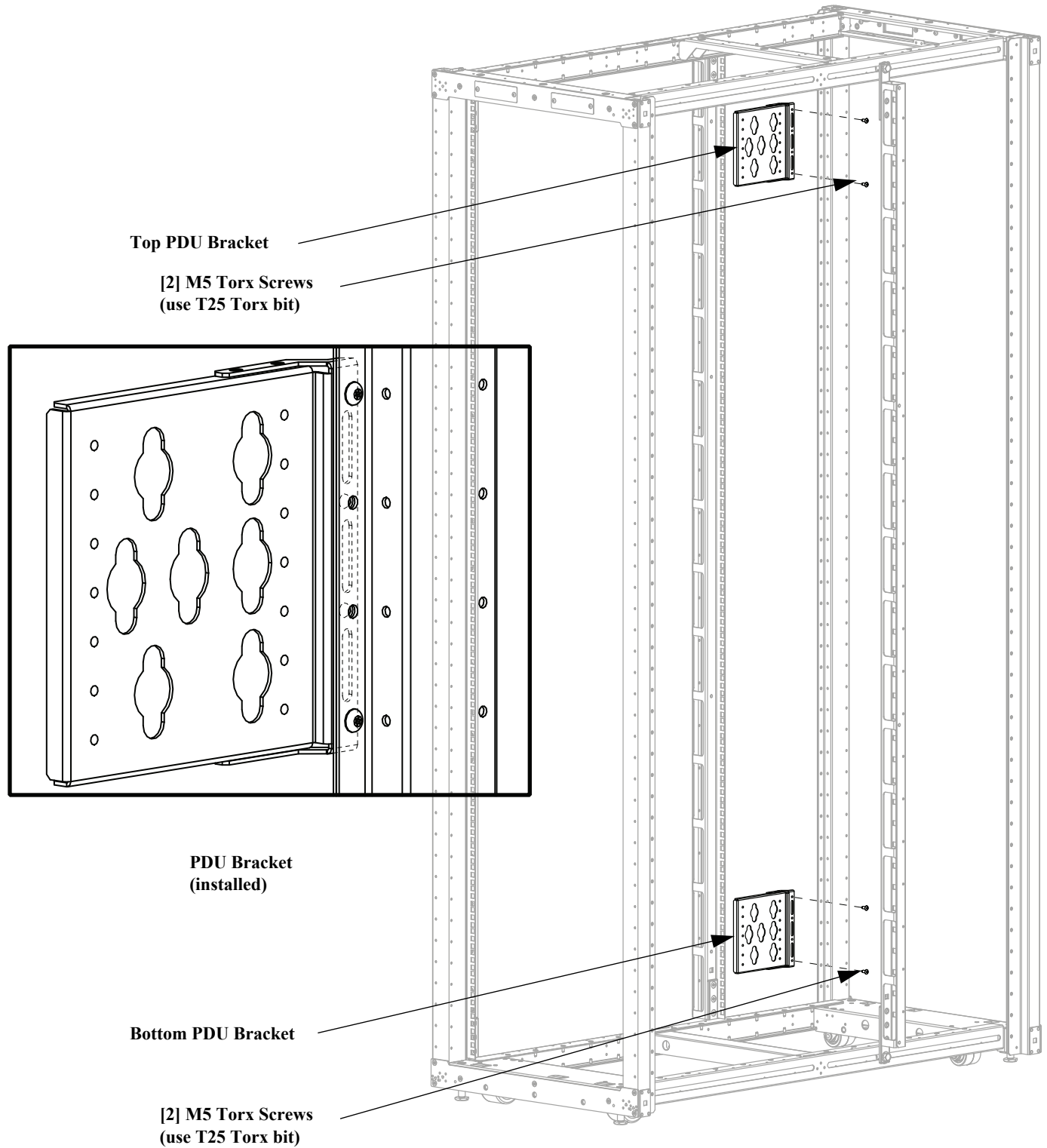

Cabinet Sealing

Install [6] Latch Plugs [3 upper, and 3 lower] into the door latch cut-outs to the front side of the cabinet only. Install [2] foam seals to the upper and lower frame. Seal should be pressed up against the Equipment Rails, behind the latch plugs.

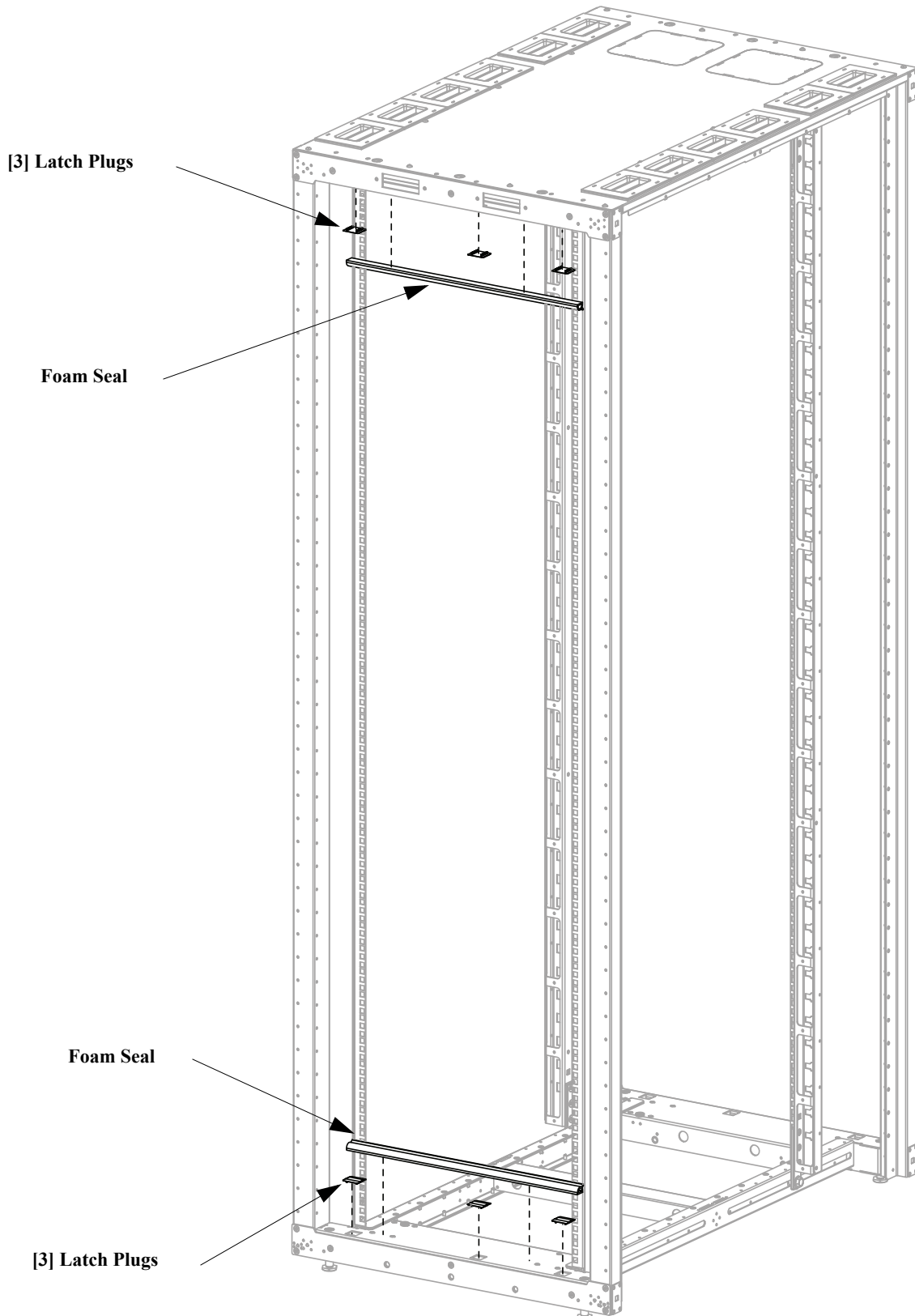

Front and Rear Floor Seal Installation (Vertical Exhaust Duct ONLY)

- Install Floor Seal to front or rear of cabinet frame using (2) M10x20mm Bolts. (Flange on floor seal will face outward away from the cabinet.)

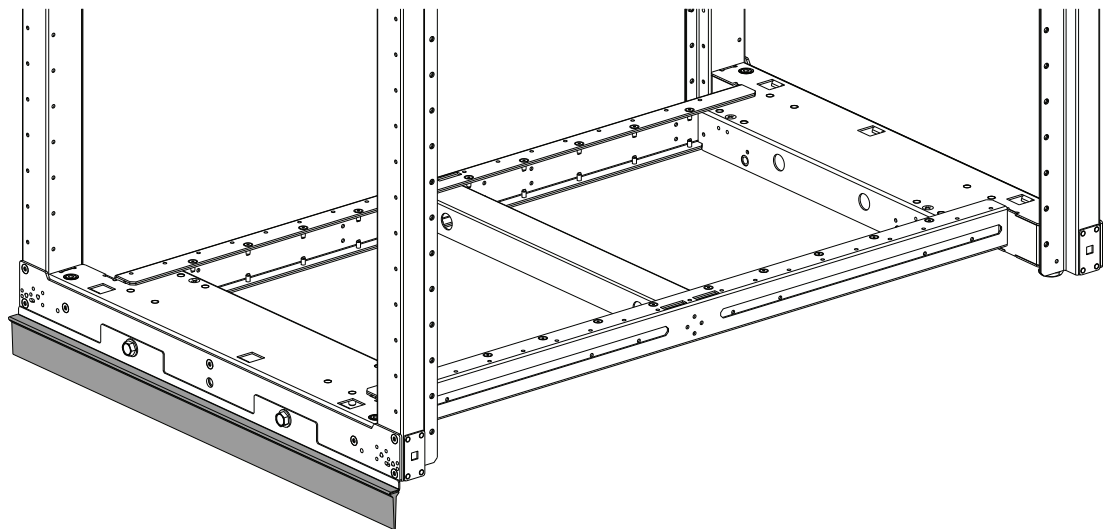
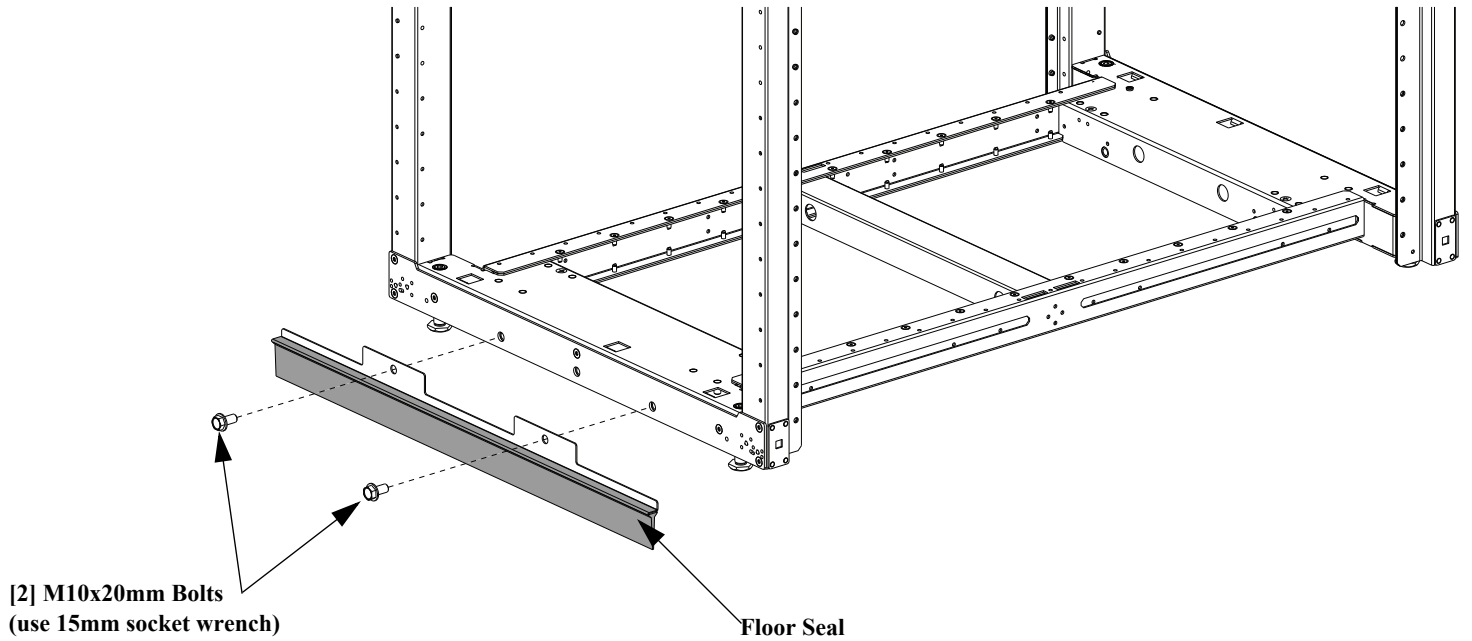

Top of Cabinet Cable Manager Installation

- Disassemble front fascia assemblies (packaged in cabinet) by removing (2) M5x0.8 button head screws (use T25 Torx bit).
- Remove (2) M5x0.8 button head screws (use T25 Torx bit) from front and rear of Cable Manager base.
- Install vertical walls on front and back of Cable Manager base using (5) M5x0.8 button head Torx screws (use T25 Torx bit). Re-install screws from previous step to secure to the frame.
- Attach front fascia to the front vertical wall by sliding fascia over studs in vertical wall.(see detail view). Tighten with (4) M5x0.8 button head screws (use T25 Torx bit).
- Attach rear fascia to the rear vertical wall by sliding fascia over studs in vertical wall (see detail view). Tighten with (4) M5x0.8 button head screws (use T25 Torx bit).

- Remove -
[4] M5 Torx Screws
(use T25 Torx bit)

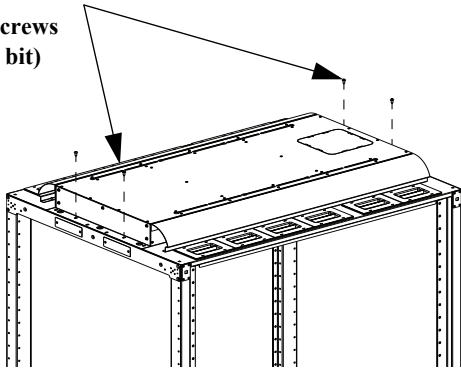

[2] Vertical Walls

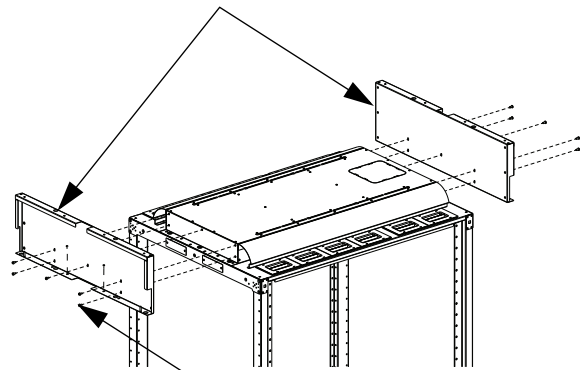

[5] M5 Torx Screws
(use T25 Torx bit)

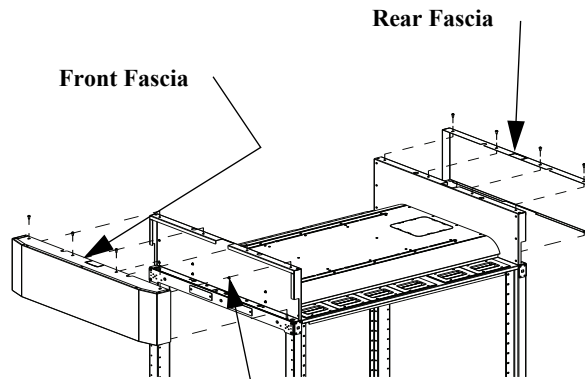

[2] Vertical Walls

[4] M5 Torx Screws
(use T25 Torx bit)

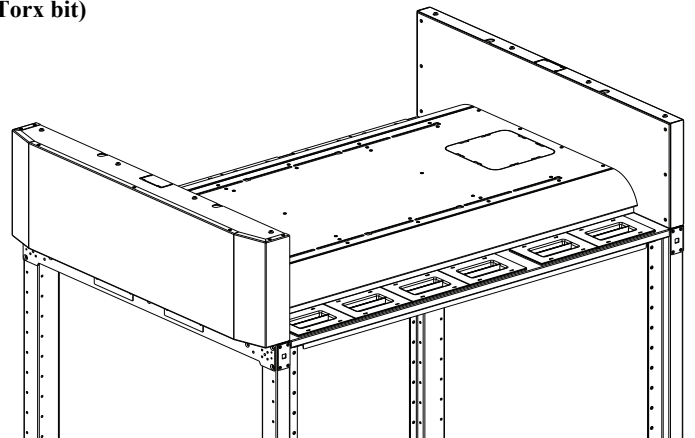
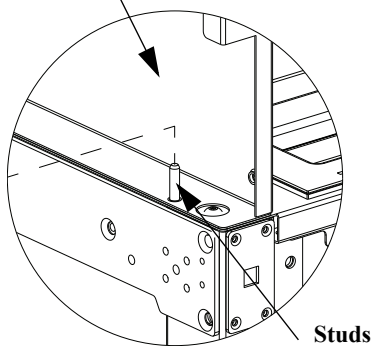

Top of Cabinet Cable Manager Installation (for vertical exhaust ducts)

IMPORTANT - INSTALL VERTICAL EXHAUST DUCT PRIOR TO INSTALLING REAR VERTICAL WALL

- Disassemble front fascia assemblies (packaged in cabinet) by removing (2) M5x0.8 button head screws (use T25 Torx bit).
- Remove (2) M5x0.8 button head screws (use T25 Torx bit) from front of Cable Manager base.
- Install vertical wall on front of Cable Manager base using (5) M5x0.8 button head Torx screws (use T25 Torx bit). Re-install screws from previous step to secure to the frame.
- Attach front fascia to the front vertical wall by sliding fascia over studs in vertical wall.(see detail view). Tighten with (4) M5x0.8 button head screws
- Attach rear vertical wall to the Cable Manger with (4) M5x0.8 button head screws (use T25 Torx bit) from underneath Top of Cabinet Cable Manager.

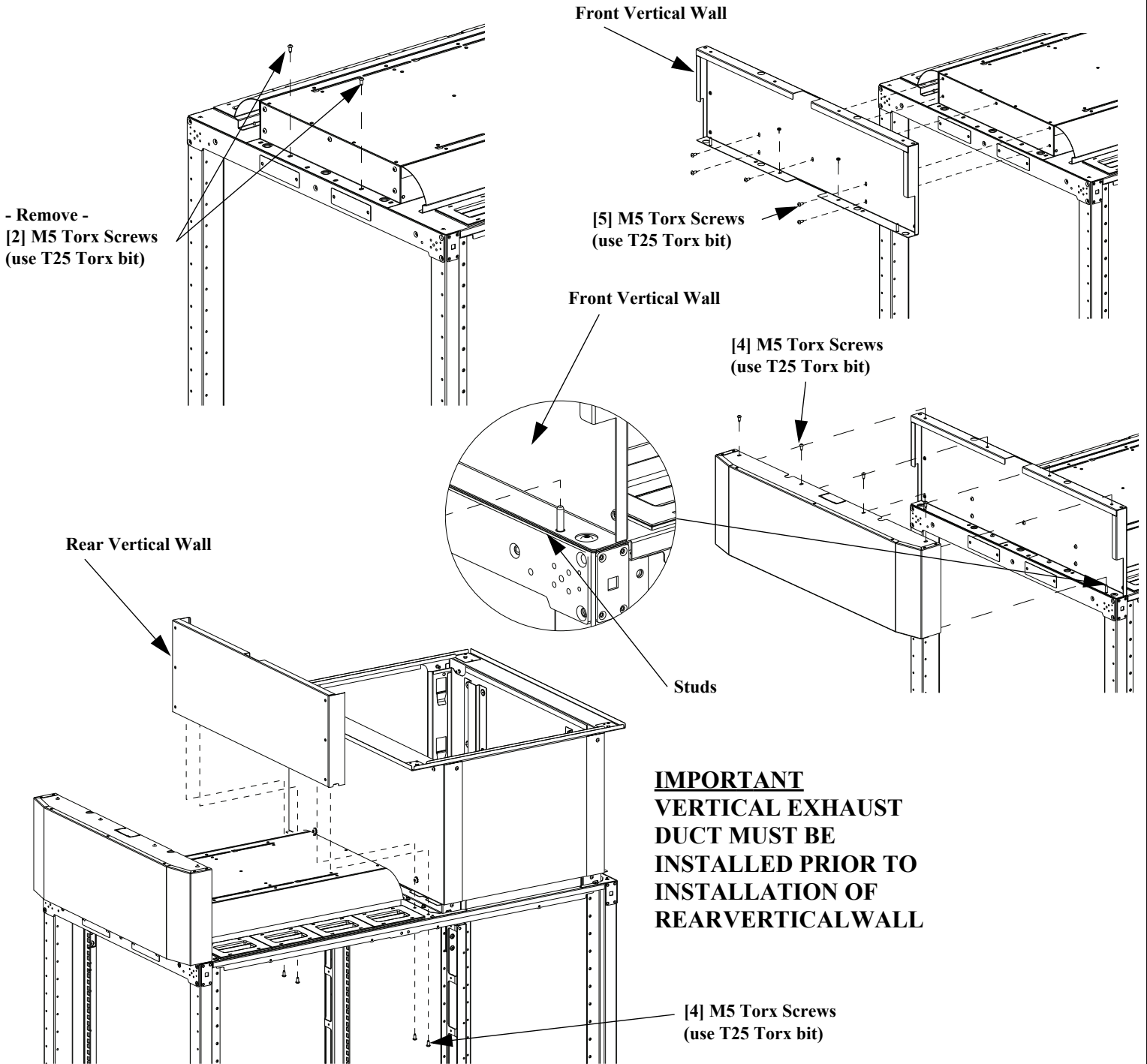

For Instructions in Local Languages
and Technical Support:

www.panduit.com/resources/install_maintain.asp

PANDUIT
www.panduit.com

E-mail:
techsupport@panduit.com
Phone:
866-405-6654