

POWERED BY

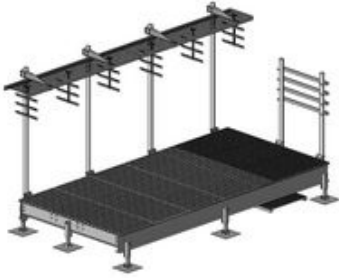

EQ-PPC

Post Power Telco Rack Kit for EQ-P Series Platforms, kit of two



Dimensions

Height	304.8 mm 12.0 in
Length	2133.6 mm 84.0 in
Weight	118.9 kg 262.1 lb
Width	2032.0 mm 80.0 in

General Specifications

Product Type	Equipment platform system
Includes	Brackets Hardware Posts Rungs
Material Type	Hot dip galvanized steel
Mounting	EQ series platform bases
Package Quantity	1

EQ-PPC

POWERED BY



Outline Drawing

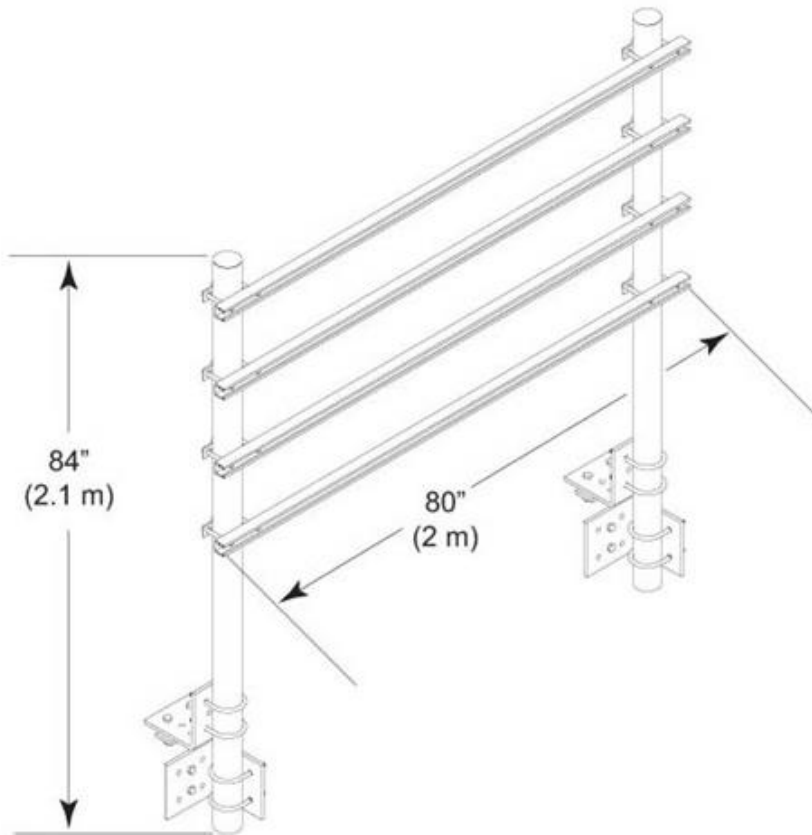

Regulatory Compliance/Certifications

Agency	Classification
ISO 9001:2008	Designed, manufactured and/or distributed under this quality management system

Included Products

EQ-PB — Post Brackets for EQ-P Series Platforms