

Middle Atlantic Products

EXCEPTIONAL SUPPORT & PROTECTION™

SCRK Series Enclosure

EIA/TIA Compliant
SEISMIC CERTIFIED
UL US LISTED

The SCRK Series 19" welded rack enclosures

Features

- Fully welded construction provides the following weight capacities: UL Listed Load Capacity: 2,500 lbs; Static Load Capacity: 10,000 lbs; Seismic Certified Load Capacity: 775 lbs
- Can be used stand-alone or ganged to a Convective Series™ console bay
- Engineered ventilation locations promote proper passive convective cooling, extending equipment life and reducing maintenance
- Available in 44 and 13 rackspace heights
- 1/2", 3/4", 1" & 1-1/2" electrical knockouts on removable split rear plates top and bottom, easily removable for cable pass-through. Top plates additionally include UHF/VHF knockouts
- Front and rear 11-gauge, 10-32 threaded rackrail with numbered rackspace increments
- Locking rear door
- Removable vented top on 44 space SCRK, other models have solid top
- Available with slide out rotating equipment rack with detachable frame that allows for off-site integration
- Seismic certified (when used with SC-Z4 option) with an Ip value of 1.5 *
- Durable textured black powder coat finish
- UL Listed in the US and Canada

*Excludes -S models (see below)



SCRK-4427GY

CABINET ACCESSORIES

 ADDITIONAL RACKRAIL KIT
 COPPER BUSS BAR
 CRATING SERVICE
 DOCUMENT POCKET
 DOOR LATCH
 UNIVERSAL FRONT DOORS
 VENT BLOCKER KITS

 for details- see Master Catalog
 or visit middleatlantic.com

Architects' and Engineers' Specifications

EIA compliant 19" equipment rack shall be Middle Atlantic Products model # SCRK-(13,44)27BK. Overall dimensions of rack shall be (27.7, 81.625)" H x 22" W x 27" D. Useable height shall be (13.44) rackspace. Fully welded construction shall provide a static capacity of 10,000 lbs. and a UL Listed Load Capacity of 2,500 lbs. Rack shall be constructed of the following materials: top and bottom shall be 16-gauge steel, horizontal braces shall be 16-gauge steel welded to integral structural side panels of 16-gauge steel giving an 1/8" thick structure, all structural elements shall be finished in a durable black powder coat. Rack shall come equipped with two pairs of fully adjustable 11-gauge steel rackrail with tapped 10-32 mounting holes in universal EIA spacing with black e-coat finish and numbered rackspace. Rack shall include solid sides with vertical slotted vent pattern at top and bottom and laser knockouts for ganging and cable pass-through. Top and bottom of rack shall feature vertical slotted vent pattern. Rack shall have a removable split rear knockout panel with 1/2", 3/4", 1", and 1-1/2" electrical knockouts installed in base. SCRK-4427 shall additionally have removable split rear knockout panels with 1/2", 3/4", 1", and 1-1/2" electrical knockouts, and BNC knockouts for UHF/VHF antennae installed in top. Grounding and bonding stud shall be 1/4-20 threaded, installed in base of enclosure. SCRK Series enclosures shall satisfy the 1997 UBC and 2001 CBC Seismic Zone 4 and the 2000 IBC, 2003 IBC, 2002 ASCE Standard 7 and NFPA 5000 Seismic Use Group III lateral force requirements for protecting 775 lbs. of essential equipment in upper floor installations when used in conjunction with the SC-Z4 seismic floor anchor brackets with an Ip value of 1.5. Rack shall have detachable frame that allows for off-site integration. Rack shall be UL Listed in the US and Canada. Rack shall be GREENGUARD Indoor Air Quality Certified for Children and Schools. Rack shall be RoHS EU Directive 2002/95/EC compliant. Rack shall be manufactured by an ISO 9001 and ISO 14001 registered company. Rack shall be warranted to be free from defects in material or workmanship under normal use and conditions for the lifetime of the rack. SCRK outfitted with rotating sliding rail system shall be Middle Atlantic Products

model # SCRK-1327BK-S and include all features of the standard SCRK-1327. The rotating sliding rail system shall have 11 useable rackspace, 23" useable depth, rotate 90° for access to equipment connections and have a 200 lb. weight capacity (enclosure will have a 2,500 lb. overall weight capacity). SCRK-1327_-S shall have a pre-installed stainless steel foot-rest. Rack with rotating sliding rail system shall be warranted to be free from defects in material or workmanship under normal use and conditions for a period of 3 years.

OPTIONS

- Front doors shall be 16-gauge steel; solid front door, 13 space shall be model # SCFD-13BK; 44 space SCRK doors shall have a black textured powder coat finish and shall be model # FD-44 (solid), VFD-44 (vented), PFD-44 (plexi)
- Top panels for 44 space SCRK, 16-gauge steel, multiple styles available including model # ERK-ST (solid), ERK-10FT (10" fan), ERK-6FT (two 6" fans) and ERK-4FT (three 4-1/2" fans) See A&E spec 96-01063 for more details
- Rear rail kit, 11-gauge, 10-32 threaded, sold in pairs, hardware included, model # ERK-RRXX (X=# of rackspace)
- Vent blockers available for 44 space SCRK, model # VBK-SCRK27
- Stainless steel foot-rest shall be model # SC-TK
- Seismic compliancy floor anchor kit, model # SC-Z4

CUSTOMIZABLE SPECIFICATION CLIPS AVAILABLE AT MIDDLEATLANTIC.COM

SCRK basic dimensions

All dimensions in inches [Bracketed dimensions in millimeters]

SCRK-4427BK



REAR VIEW
(rear door removed for clarity)
see DETAIL A

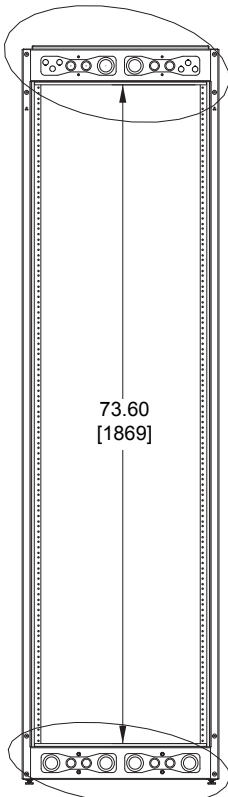

see DETAIL B

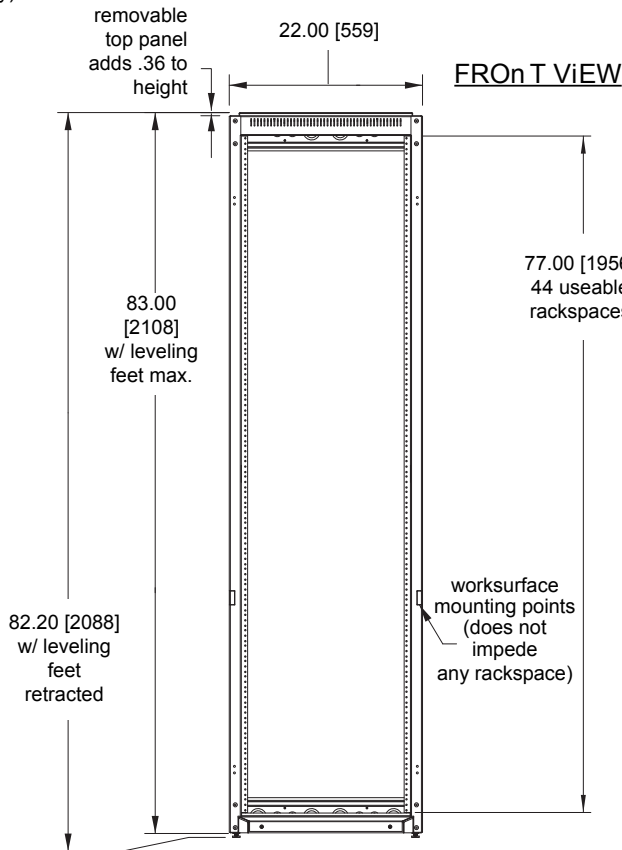

FRONT VIEW

TOP VIEW

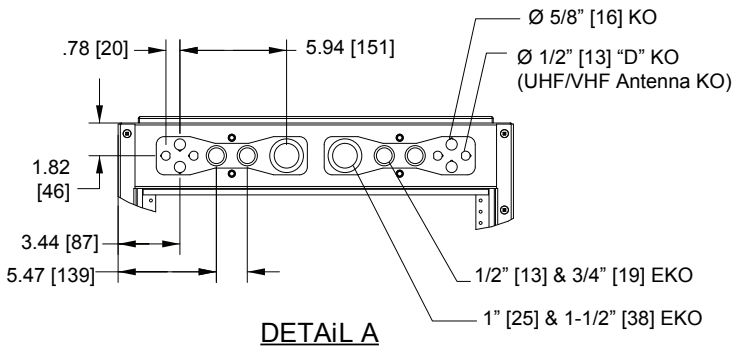
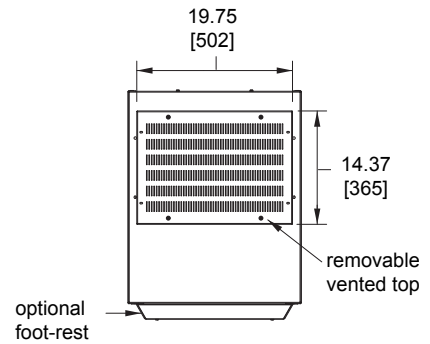

DETAIL A

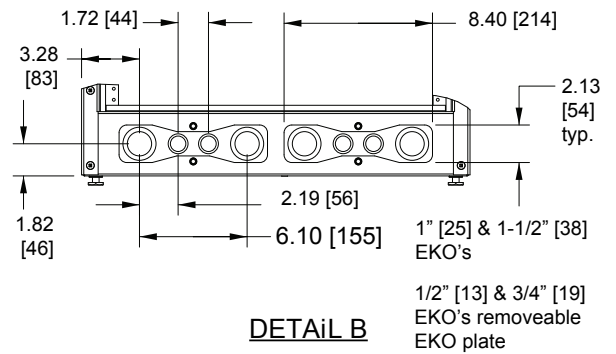

DETAIL B

TOP OpTiOnS

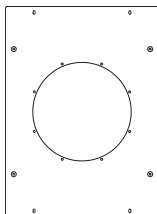

ERK-10FT accepts 10" fan
ERK-10FT-550CFM includes 10" fan
ERK-10FT-FC includes 10" fan and fan controller

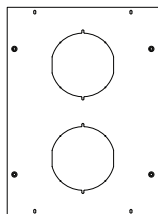

ERK-6FT accepts two 6" fans
ERK-6FT-440CFM includes two 6" fans

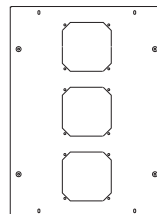

ERK-4FT accepts three 4-1/2" fans
ERK-4FT-285CFM includes three 4-1/2" fans
ERK-4FT-FC includes 4-1/2" quiet fans and fan controller

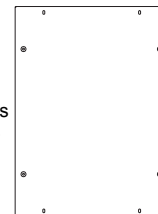

ERK-ST solid

SCRK basic dimensions

All dimensions in inches [Bracketed dimensions in millimeters]

SCRK-4427BK

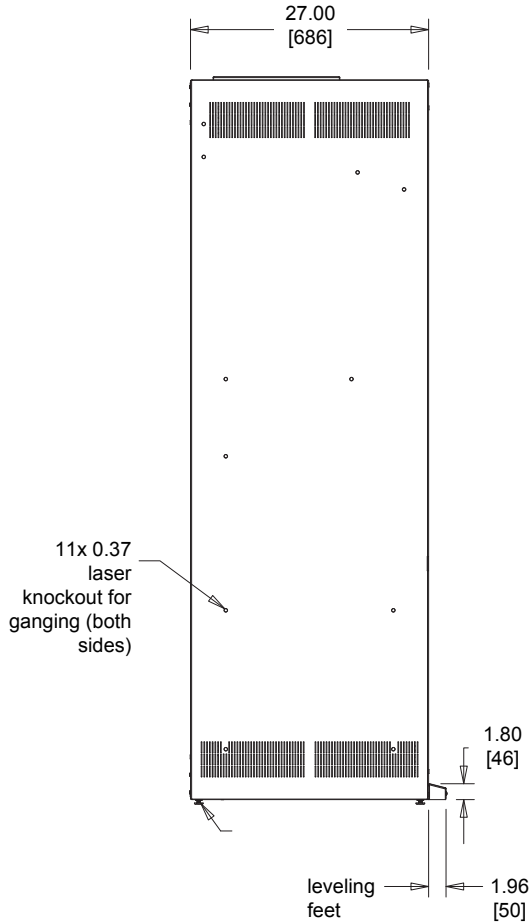

SIDE VIEW, EXTERIOR

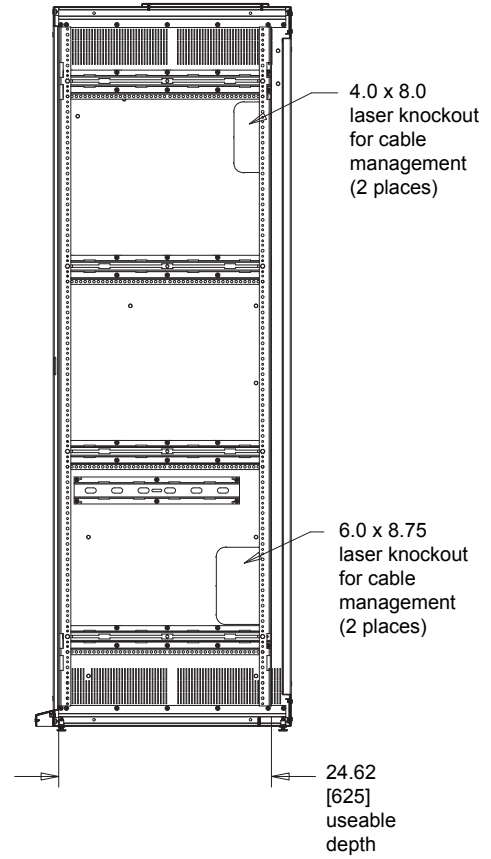

SIDE VIEW, INTERIOR

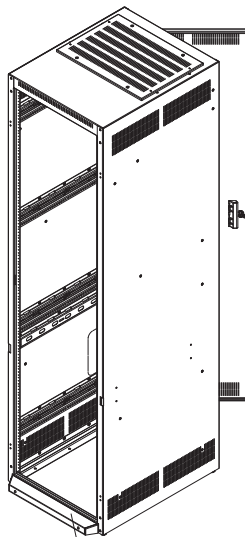

optional
foot-rest, SC-TK

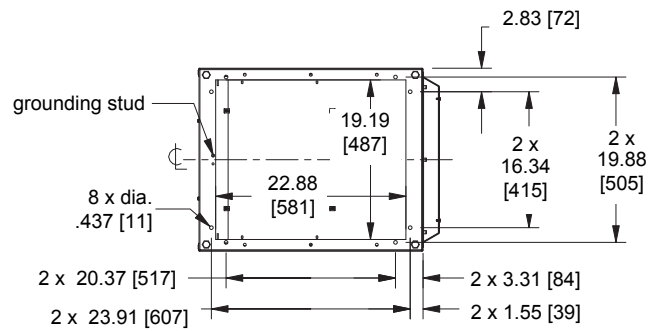

BOTTOM VIEW



SCRK basic dimensions

All dimensions in inches [Bracketed dimensions in millimeters]

SCRK-1327BK



DETAIL C

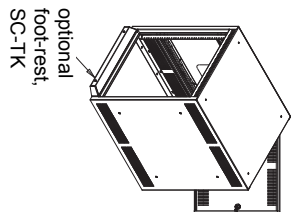
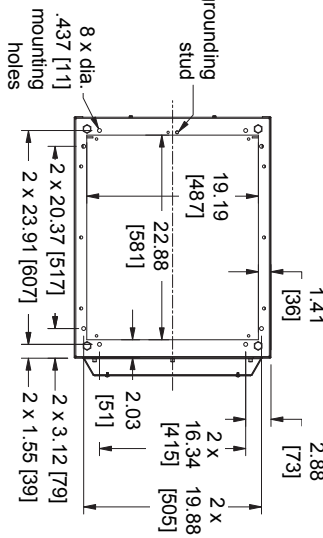
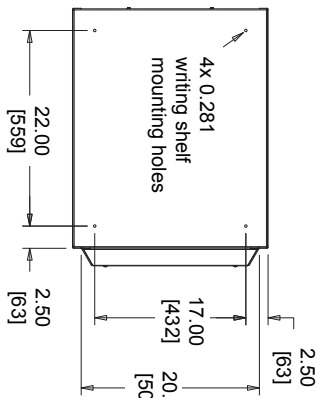
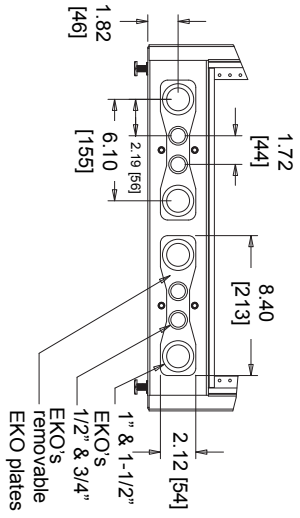

TOP VIEW

BOTTOM VIEW

REAR VIEW

(shown with rear door removed for clarity)

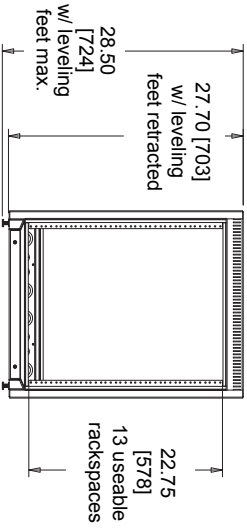
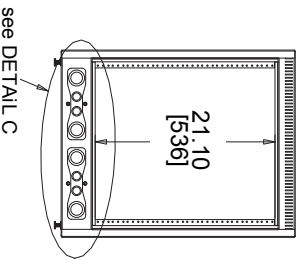

FRONT VIEW

SIDE VIEW, EXTERIOR

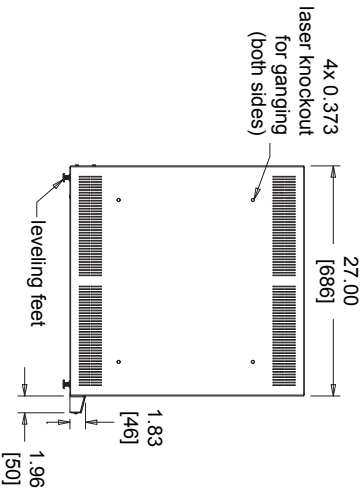

SIDE VIEW, INTERIOR

