

NOTES:

1. DUSTCAPS ARE PROVIDED INSTALLED.
2. DIMENSIONS ARE IN INCHES.
3. THE "-XX" AT THE END OF THE PART NUMBER SHALL INDICATE THE COLOR OF HOUSING. COLOR SHALL BE IN ACCORDANCE WITH ORTRONICS SPECIFICATION #OR-71601388.

 INDICATES NOTE REFERENCE

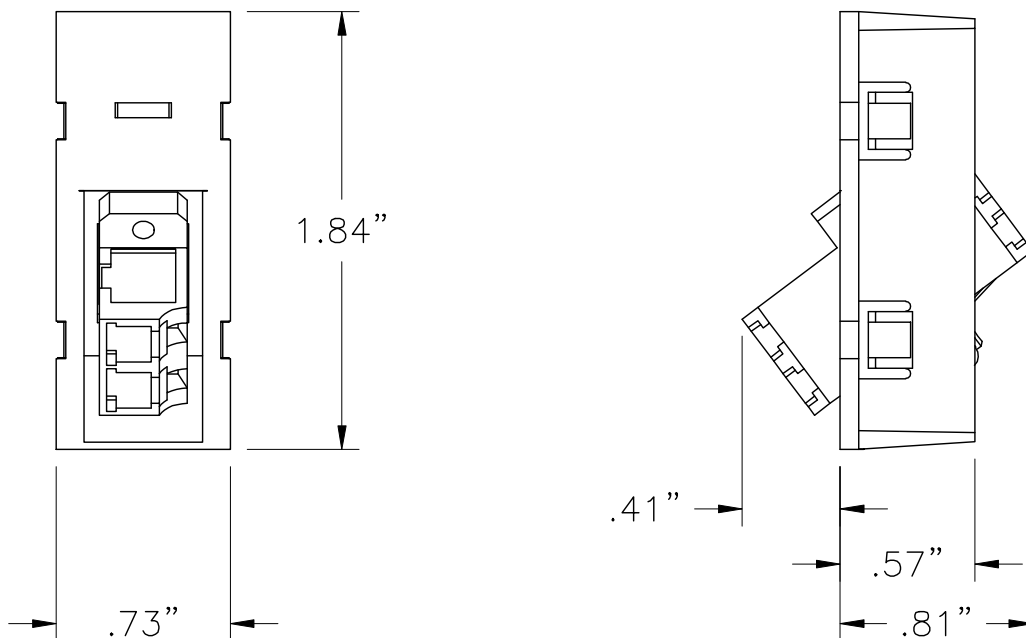
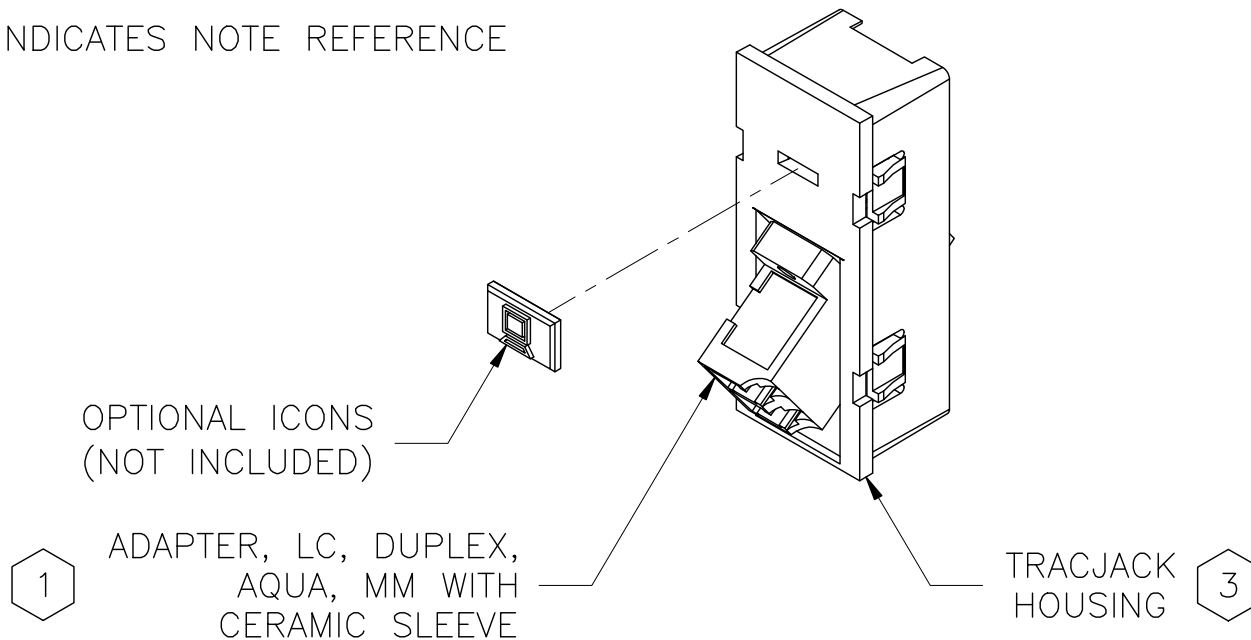

\*\*\* NOTICE \*\*\*

THIS DOCUMENT CONTAINS CONFIDENTIAL AND/OR PROPRIETARY INFORMATION INTENDED FOR USE ONLY BY THE INDIVIDUAL(S) SPECIFIED HEREIN AND ONLY FOR THE PURPOSE(S) PROVIDED. NEITHER THIS DOCUMENT, NOR ANY INFORMATION CONTAINED HEREIN, MAY BE COPIED, DISTRIBUTED, DISCLOSED TO ANY THIRD PARTY OR USED IN ANY MANNER OTHER THAN FOR WHICH IT HAS BEEN PROVIDED, WITHOUT THE PRIOR WRITTEN CONSENT OF ORTRONICS, INC.



NEW LONDON, CT 06320  
(860) 445-3800

DWN.BY:	RYNASKI	DATE	11/21/07
CHK.BY:	AM	DATE	12/19/07
APP.BY:	MEM	DATE	12/19/07

TITLE

TRACJACK, ANGLED WITH  
LC ADAPTER

SIZE	CAD FILE	PART NUMBER	REV
A	63700080XXC	OR-63700080-XX	01
SCALE	REL DATE	SHEET	
NONE	06/03/09	1 OF 1	