

THIS COPY IS PROVIDED ON A RESTRICTED BASIS AND IS NOT TO BE USED IN ANY WAY DETRIMENTAL TO THE INTERESTS OF PANDUIT CORP.

NOTES:

1. VISIT OUR ONLINE CATALOG AT WWW.PANDUIT.COM FOR A LIST OF USE WITH THIS PRODUCT.
2. PRIMARY DIMENSIONS ARE IN MILLIMETERS (mm) DIMENSIONS IN PARENTHESES ARE IN INCHES (IN).
3. PARTS SUPPLIED:
 - 2 - BOTTOM SIDE PANELS
 - 2 - TOP SIDE PANELS
 - 1 - TOP FRONT PANEL
 - 1 - TOP REAR PANEL
 - 2 - BOTTOM FRONT AND REAR PANELS
 - 2 - HORIZONTAL ADJUSTMENT BRACKETS
 - 1 - HARDWARE KIT

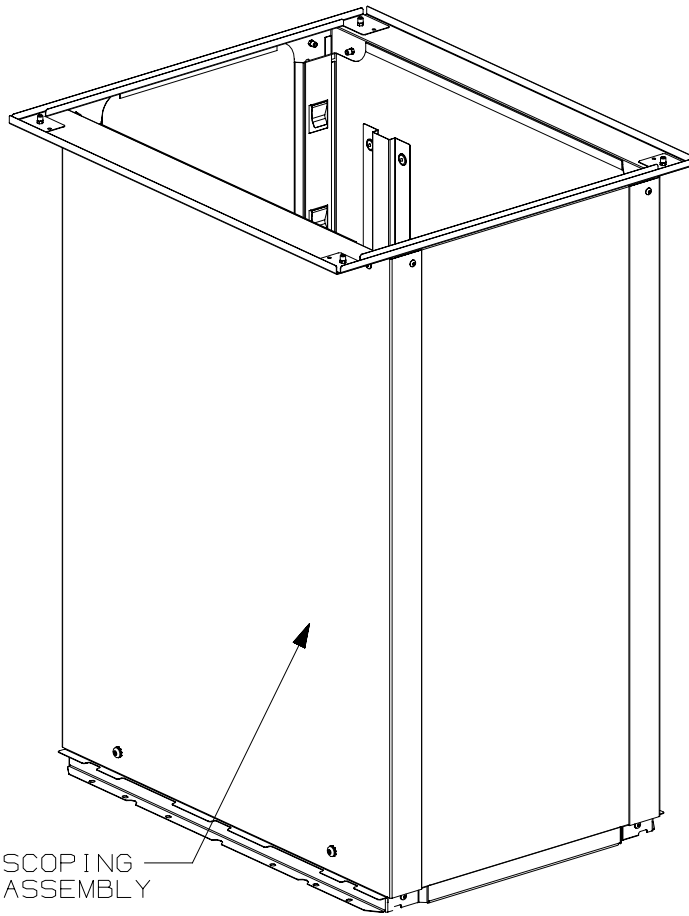

PANDUIT PART NO.	HEIGHT	FOR USE WITH CABINET SIZE (WIDTH X DEPTH)
C2VED06I1626XX	406mm [16"] - 660mm [26"]	600mm X 1200mm
C2VED06I2638XX	660mm [26"] - 965mm [38"]	600mm X 1200mm
C2VED06I3866XX	965mm [38"] - 1676mm [66"]	600mm X 1200mm
C2VED07I1626XX	406mm [16"] - 660mm [26"]	700mm X 1200mm
C2VED07I2638XX	660mm [26"] - 965mm [38"]	700mm X 1200mm
C2VED07I3866XX	965mm [38"] - 1676mm [66"]	700mm X 1200mm
C2VED08I1626XX	406mm [16"] - 660mm [26"]	800mm X 1200mm
C2VED08I2638XX	660mm [26"] - 965mm [38"]	800mm X 1200mm
C2VED08I3866XX	965mm [38"] - 1676mm [66"]	800mm X 1200mm

*XX = COLOR
 B1 = BLACK
 W1 = WHITE

REV	DATE	BY	CHK	APR	DESCRIPTION	ECN
01A	02/11/13	ERK			C. UPDATED PARTS SUPPLIED LIST B. ADDED SHEET 4 A. UPDATED TO REFLECT NEW GEOMETRY AND HARDWARE	12V285ZV
00A	10/16/12	PJST	BKR	BKR	RELEASED TO PRODUCTION	12V285ZV

TITLE NET-CONTAIN™ VERTICAL EXHAUST DUCT FOR N OR S TYPE CABINETS CUSTOMER DRAWING					
ITEM REVISION NAME 12V285ZV/01			PANDUIT™		
DATASET FILE NAME 12V285ZV_DC/01A					
DRAWN BY PJST			DATE 10/16/12		CHK BKR
SCALE N/A			DRAWING NUMBER: 12V285ZV		SIZE A
SHT 1 OF 4					

D10100DA/12

2

1

THIS COPY IS PROVIDED ON A RESTRICTED BASIS AND IS NOT TO BE USED IN ANY WAY DETRIMENTAL TO THE INTERESTS OF PANDUIT CORP.

PANDUIT PART NO.	WIDTH	WEIGHT
C2VED0611626XX	588mm [23.1"]	12.13 Kg (26.7 LBS) EA.
C2VED0612638XX	588mm [23.1"]	17.35 Kg (38.2 LBS) EA.
C2VED0613866XX	588mm [23.1"]	28.33 Kg (62.4 LBS) EA.
C2VED0711626XX	688mm [27.1"]	13.10 Kg (28.8 LBS) EA.
C2VED0712638XX	688mm [27.1"]	18.64 Kg (41.0 LBS) EA.
C2VED0713866XX	688mm [27.1"]	30.48 Kg (67.2 LBS) EA.
C2VED0811626XX	788mm [31.0"]	14.07 Kg (31.0 LBS) EA.
C2VED0812638XX	788mm [31.0"]	20.00 Kg (44.0 LBS) EA.
C2VED0813866XX	788mm [31.0"]	32.72 Kg (72.1 LBS) EA.

A

REV	DATE	BY	CHK	APR	DESCRIPTION	ECN
--	---	--			SEE SHEET 1 OF 4 FOR REVISIONS	12V285AP

TITLE		MATERIAL:	
NET-CONTAIN™ VERTICAL EXHAUST DUCT FOR N OR S TYPE CABINETS CUSTOMER DRAWING		N/A	
ITEM REVISION NAME	12V285ZV/01	PANDUIT™	
DATASET FILE NAME	12V285ZV_DC/01A		
DRAWING NUMBER:		12V285ZV	
DRAWN BY	DATE	CHK	SCALE
PJST	10/16/12		N/A
SHT 3 OF 4			SIZE A

2

1

D10100DA/12

THIS COPY IS PROVIDED ON A RESTRICTED BASIS AND IS NOT TO BE USED IN ANY WAY DETRIMENTAL TO THE INTERESTS OF PANDUIT CORP.

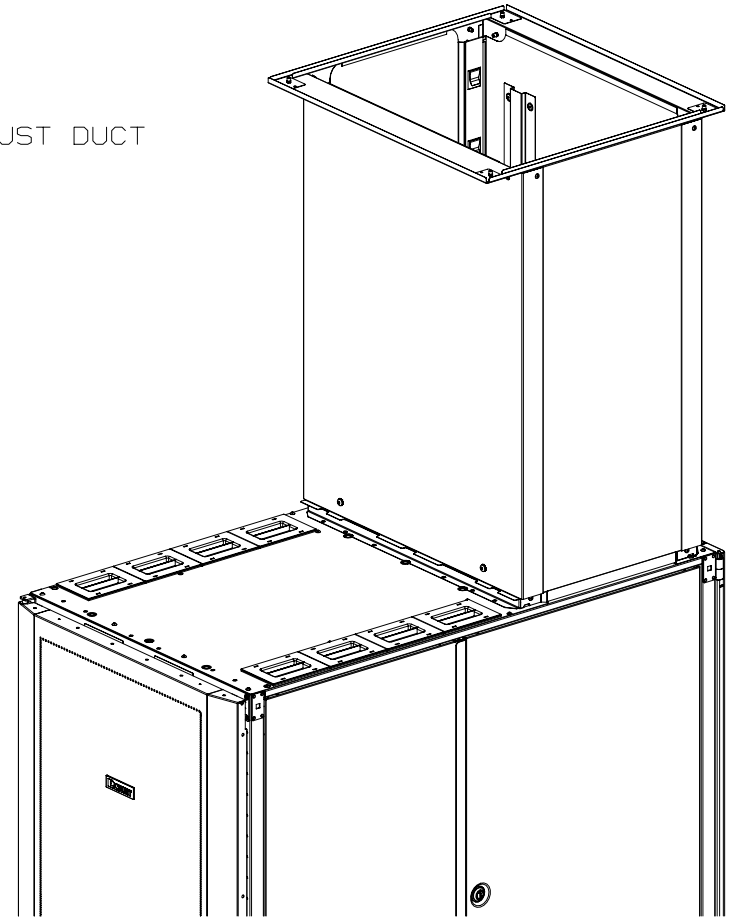
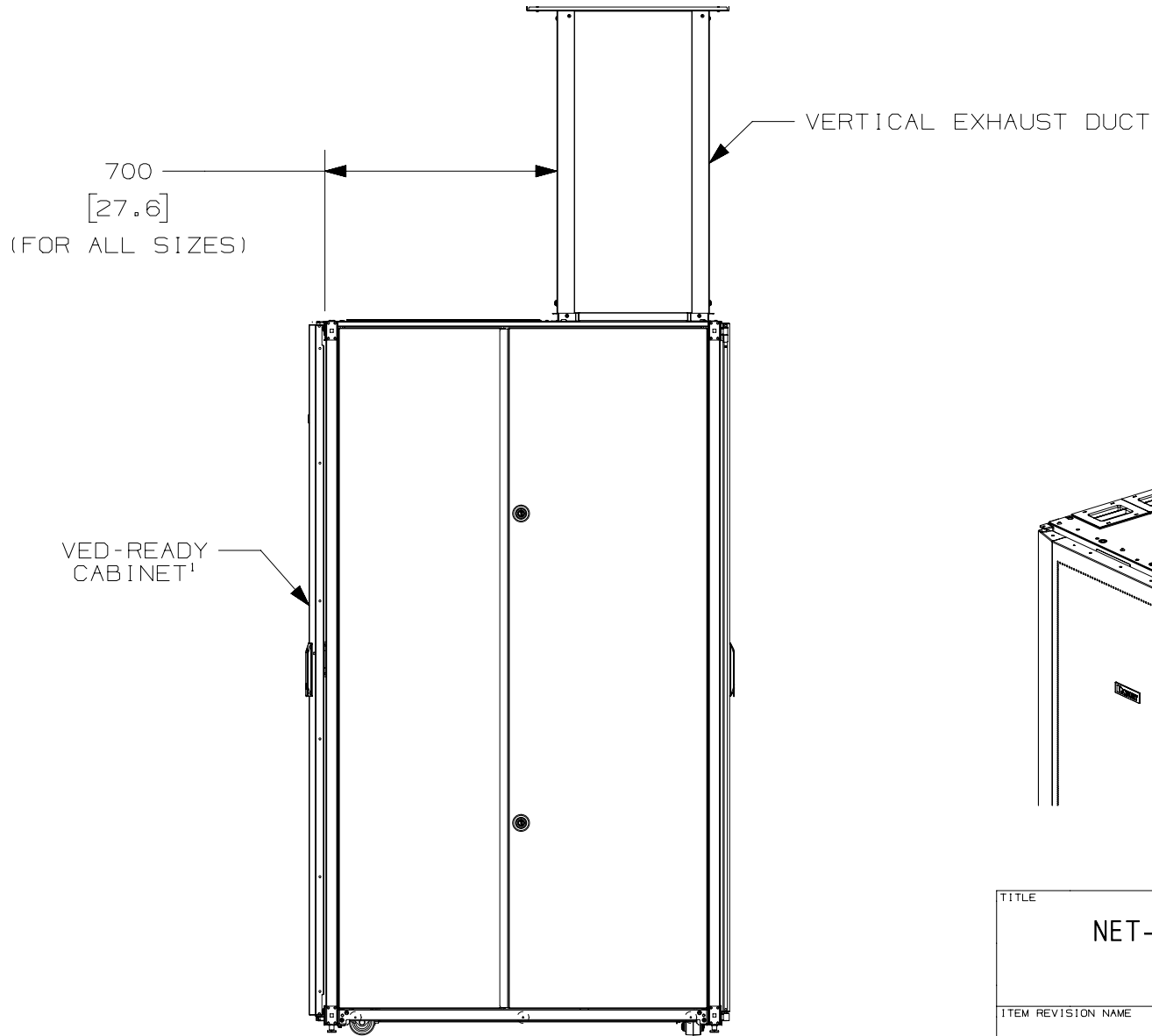

1. THE NET-CONTAIN™ VERTICAL EXHAUST DUCT CAN ONLY BE USED WITH A VED-READY TYPE CABINET (PURCHASED SEPARATELY).

TITLE										
NET-CONTAIN™ VERTICAL EXHAUST DUCT FOR N OR S TYPE CABINETS										
CUSTOMER DRAWING										
ITEM REVISION NAME					12V285ZV/01					
DATASET FILE NAME					12V285ZV_DC/01A					
					MATERIAL:					
					N/A					
					DRAWING NUMBER:					
					12V285ZV					
DRAWN BY		DATE		CHK		SCALE				
PJST		10/16/12				N/A				
SEE SHEET 1 OF 4 FOR REVISIONS					ECN		SHT 4 OF 4			SIZE
					12V285AP					A
REV	DATE	BY	CHK	APR	DESCRIPTION				ECN	SIZE
--	---	--			SEE SHEET 1 OF 4 FOR REVISIONS				12V285AP	A

D10100DA/12