

OMNI CONSOLE FLUSH MOUNT KIT

Cat. No. 33A00-3

Installation Instructions and User's Guide



DI-022-OA333-05AAR2243
(33100-3)

INSTALLATION

ENGLISH

WARNINGS AND CAUTIONS

- Read and understand all instructions. Follow all warnings and instructions marked on the product.
- Do not use this product near water - e.g., near a tub, wash basin, kitchen sink or laundry tub, in a wet basement, or near a swimming pool.
- Never push objects of any kind into this product through openings, as they may touch dangerous voltages.
- SAVE THESE INSTRUCTIONS.

WARNINGS AND CAUTIONS

- Never install communications wiring or components during a lightning storm.
- Never install communications components in wet locations unless the components are designed specifically for use in wet locations.
- Never touch uninsulated wires or terminals unless the wiring has been disconnected at the network interface.
- Use caution when installing or modifying communications wiring or components.

INSTALLING THE FLUSH MOUNT CONSOLE KIT

1. Place the Flush Mount back box against the wall at the desired location with the top and bottom edges level. Note the orientation in the figure.

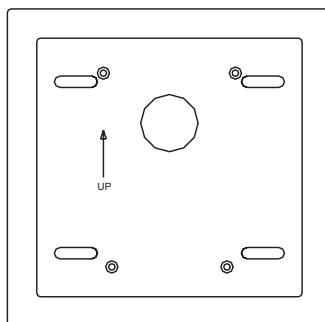

2. Mark an outline around the base of the back box. Carefully cut along this mark. Do not over size. Check the fit of the back box into the cut-out. Resize if necessary.
3. Attach the Flush Mount Retention Brackets to the Back Box using the #8 machine screws and flat washers provided. Mount the Back Box into the cut-out as shown.

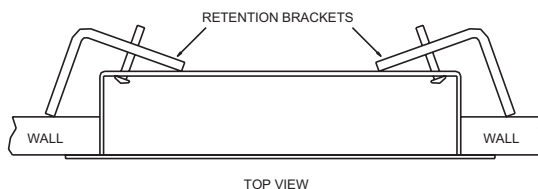

4. Alternatively, the Flush Mount Back Box can be located near and attached to a stud. See figure.
5. Attach the Console Back Housing into the Flush Mount Back Box using the #6 screws provided.

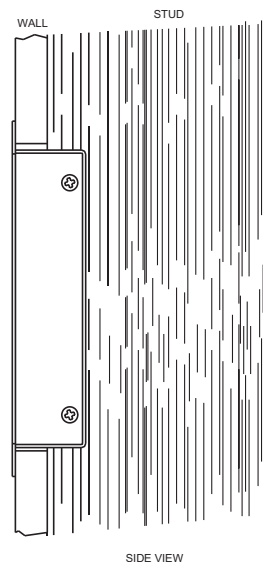

6. Wire according to the Controller installation instructions.
7. Snap the Console Front to the Console Back.

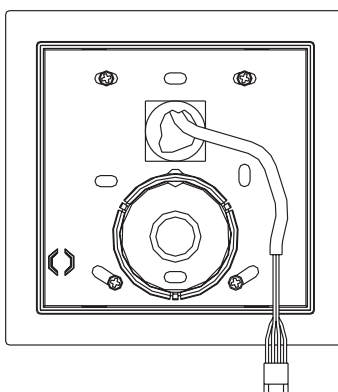

FOR CANADA ONLY

For warranty information and/or product returns, residents of Canada should contact Leviton in writing at **Leviton Manufacturing of Canada Ltd to the attention of the Quality Assurance Department, 165 Hymus Blvd, Pointe-Claire (Quebec), Canada H9R 1E9** or by telephone at **1 800 405-5320**.

LEVITON LIMITED WARRANTY

Leviton warrants to the original consumer purchaser and not for the benefit of anyone else that products manufactured by Leviton under the Leviton brand name ("Product") will be free from defects in material and workmanship for the time periods indicated below, whichever is shorter: • **OmniPro II and Lumina Pro:** three (3) years from installation or 42 months from manufacture date. • **OmniLT, Omni II, and Lumina:** two (2) years from installation or 30 months from manufacture date. • **Thermostats, Accessories:** two (2) years from installation or 30 months from manufacture date. • **Batteries:** Rechargeable batteries in products are warranted for ninety (90) days from date of purchase. **Note:** Primary (non-rechargeable) batteries shipped in products are not warranted. **Products with Windows® Operating Systems:** During the warranty period, Leviton will restore corrupted operating systems to factory default at no charge, provided that the product has been used as originally intended. Installation of non-Leviton software or modification of the operating system voids this warranty. Leviton's obligation under this Limited Warranty is limited to the repair or replacement, at Leviton's option, of Product that fails due to defect in material or workmanship. Leviton reserves the right to replace product under this Limited Warranty with new or remanufactured product. **Leviton will not be responsible for labor costs of removal or reinstallation of Product.** The repaired or replaced product is then warranted under the terms of this Limited Warranty for the remainder of the Limited Warranty time period or ninety (90) days, whichever is longer. This Limited Warranty does not cover PC-based software products. **Leviton is not responsible for conditions or applications beyond Leviton's control. Leviton is not responsible for issues related to improper installation, including failure to follow written installation and operation instructions, normal wear and tear, catastrophe, fault or negligence of the user or other problems external to the Product.** To view complete warranty and instructions for returning product, please visit us at www.leviton.com.

Use herein of third party trademarks, service marks, trade names, brand names and/or product names are for informational purposes only, are/may be the trademarks of their respective owners; such use is not meant to imply affiliation, sponsorship, or endorsement.

WEB VERSION