

1", 2", AND 3" REAR SECTION
NOMINAL CONCENTRIC CONDUIT
KNOCKOUT

2 FAN UNIT MOUNTING SHOWN FOR
GL24WM, GL36WM, & GL48WM.
2 FAN UNIT MOUNTING IS ROTATED
90 DEGREES ON GL2418WM.

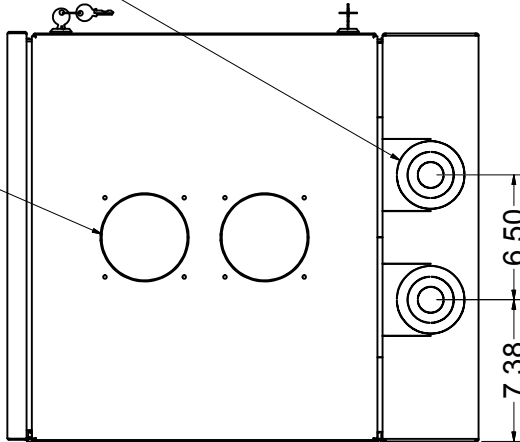

TOP VIEW

INDEPENDENT LOCKING FRONT
AND REAR DOOR SECTION

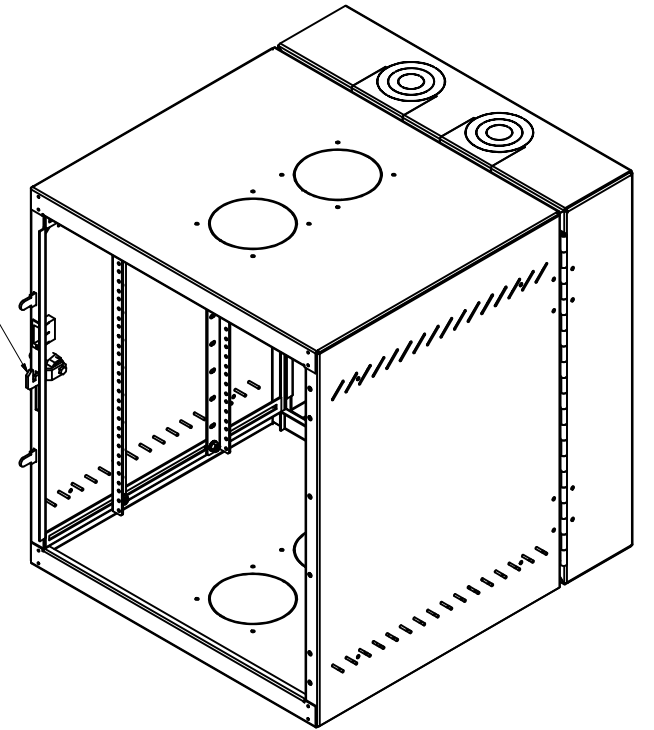

ISO COLLAPSED
(without Door)

MOUNTING HOLES FOR
3/8" HARDWARE

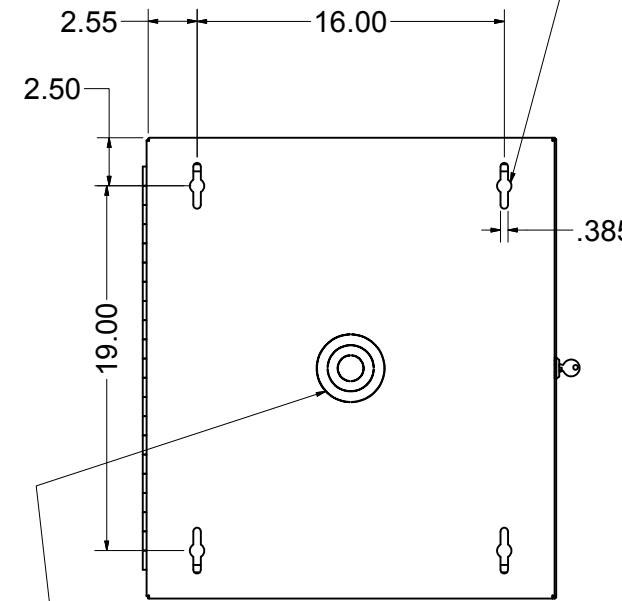

BACK VIEW

1", 2", 3", AND 4" REAR SECTION
NOMINAL CONCENTRIC CONDUIT
KNOCKOUT

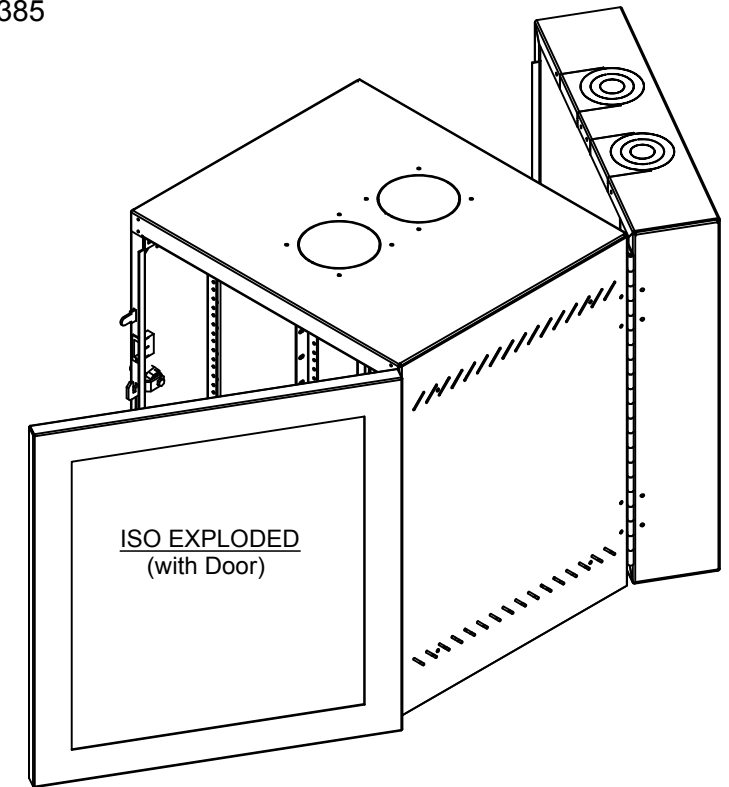

ISO EXPLODED
(with Door)

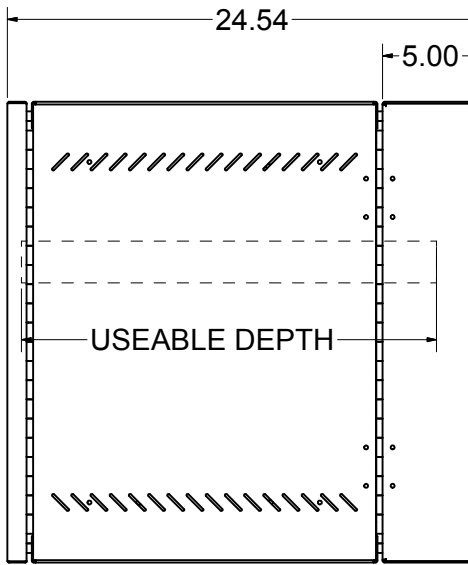

RIGHT SIDE VIEW

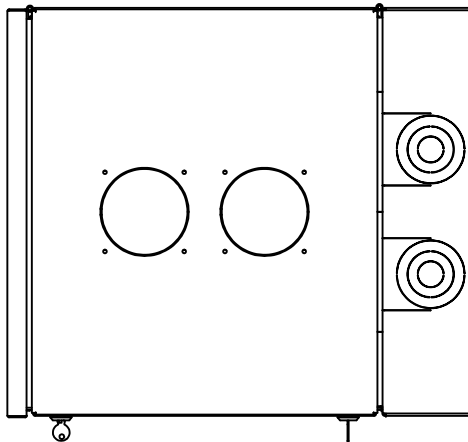

BOTTOM VIEW

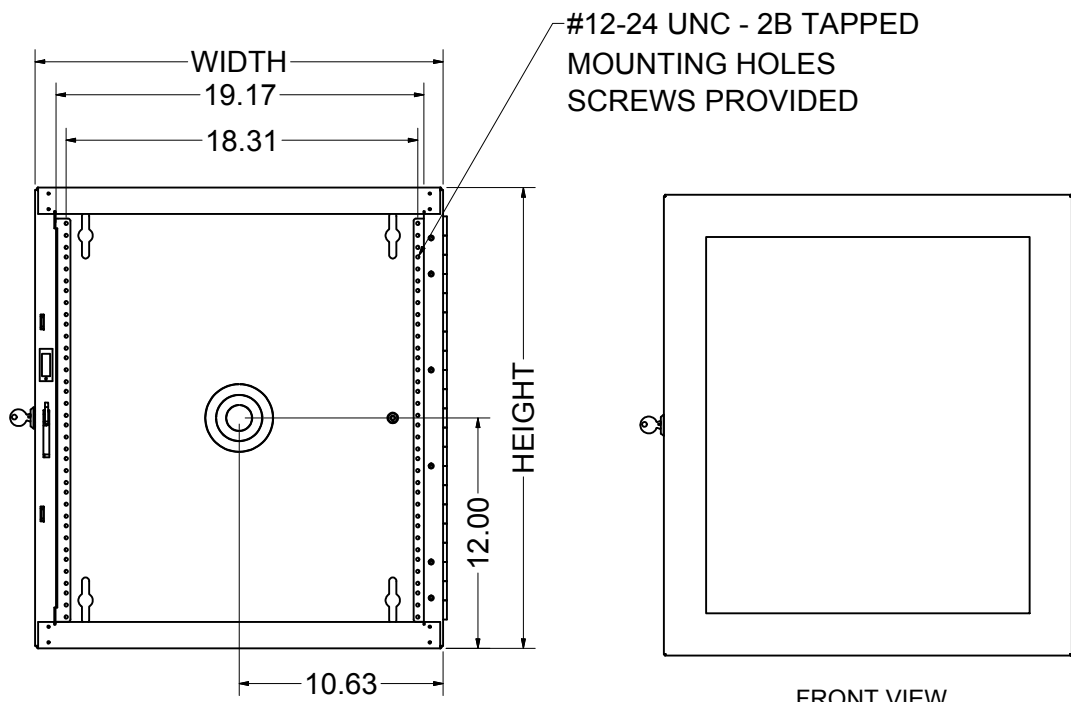

FRONT VIEW
(without Door)

FRONT VIEW
(with Door)

PART No.	HEIGHT	WIDTH	DEPTH	UABLE DEPTH	RMU
GL2418WM	24.00"	21.25"	18.00"	15.5"	12
GL24WM	24.00"	21.25"	24.50"	22.0"	12
GL36WM	36.00"	21.25"	24.50"	22.0"	19
GL48WM	48.00"	21.25"	24.50"	22.0"	25

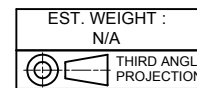

EST. WEIGHT :
N/A

INTERPRET DRAWING PER ASME Y14.5M-1994
DIMENSIONAL LIMITS APPLY
AFTER APPLICATION OF FINISH
DRAWING NOT TO SCALE
TOLERANCE UNLESS OTHERWISE NOTED:
ANGULAR +/- .1"
.XXXX +/- .010
.XXX +/- .015
.XX +/- .030
.X FOR REF. ONLY

UNLESS OTHERWISE SPECIFIED
ALL DIMENSIONS ARE IN INCHES

NOTICE:

Use of this document is subject to a confidentiality and nondisclosure agreement with Great Lakes Case & Cabinet Co., Inc. (GLCC) and may not be reproduced, disclosed or utilized in whole or in part without prior written authorization from GLCC.

PART NUMBER: SEE CHART	
QTY PER UNIT:	1
MATERIAL TYPE:	C.R.S.
MATERIAL GAUGE:	VARIABLE
FINISH:	TXT POWDER COAT
DRAWN CD	DATE 3/4/2011
CHECKED & APP. WSS	DATE 3/4/2011

TITLE WM Wall Mount Enclosures	
GREAT LAKES CASE & CABINET CO., INC. P.O. BOX 551 EDINBORO, PA 16412 PHONE (814) 734-7303 FAX (814) 734-3907 E-MAIL glcc@greatcabinets.com	
DWG NO. 1005292	REV 0
SHEET: 1 OF 1	