

REVISION HISTORY			
REV	DESCRIPTION	DATE	APPROVED
2	ECO-02787	2/15/2010	FED
3	ECO-03254	6/14/2011	FED

Bill of Material						
ITEM	PART NUMBER	STOCK NUMBER	QTY	DESCRIPTION	FILE NAME	REVISION
1			1	MOUNTING BRACKET FOR CM09	I011588.ipt	2
2	S01-001		9	CABLE RING FOR CM05 & CM09	I011591.ipt	3

NOTES:

- DIMENSIONS APPLY BEFORE APPLICATION OF FINISH:
ADD .005" TO EACH SURFACE FOR INSPECTION.**
- FINISH PER TD-09-103 (POWDER COAT), CLASS B,
TEXTURE LEVEL 3, ALL SURFACES UNLESS OTHERWISE NOTED.**

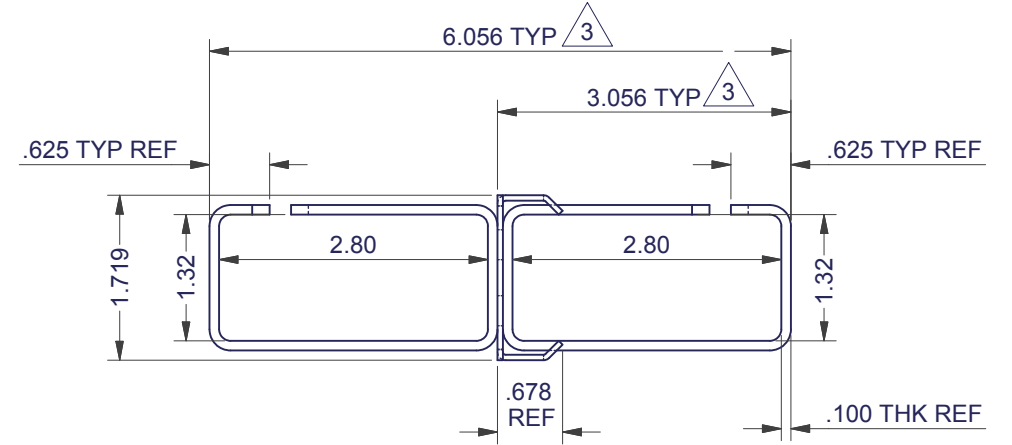
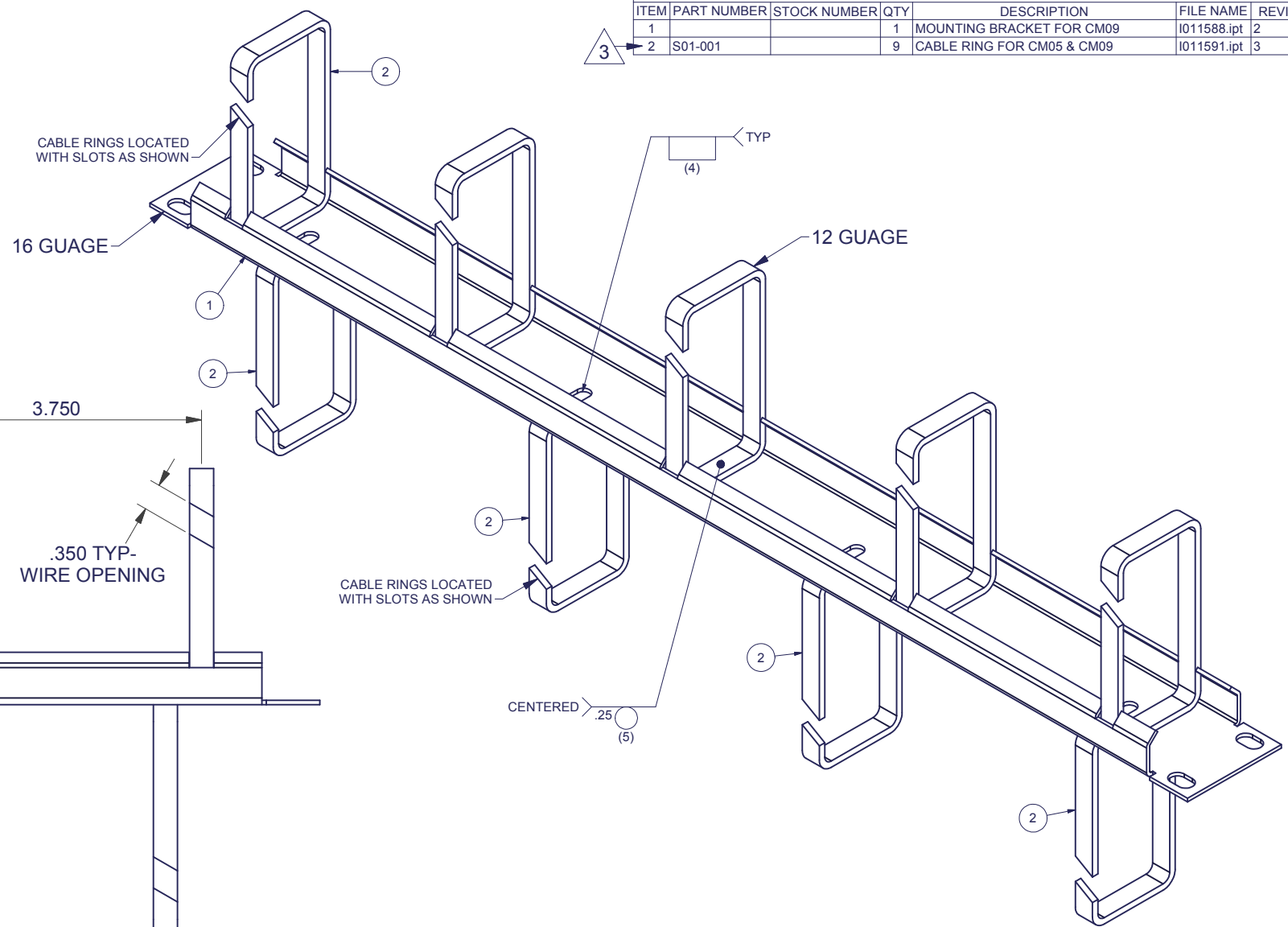
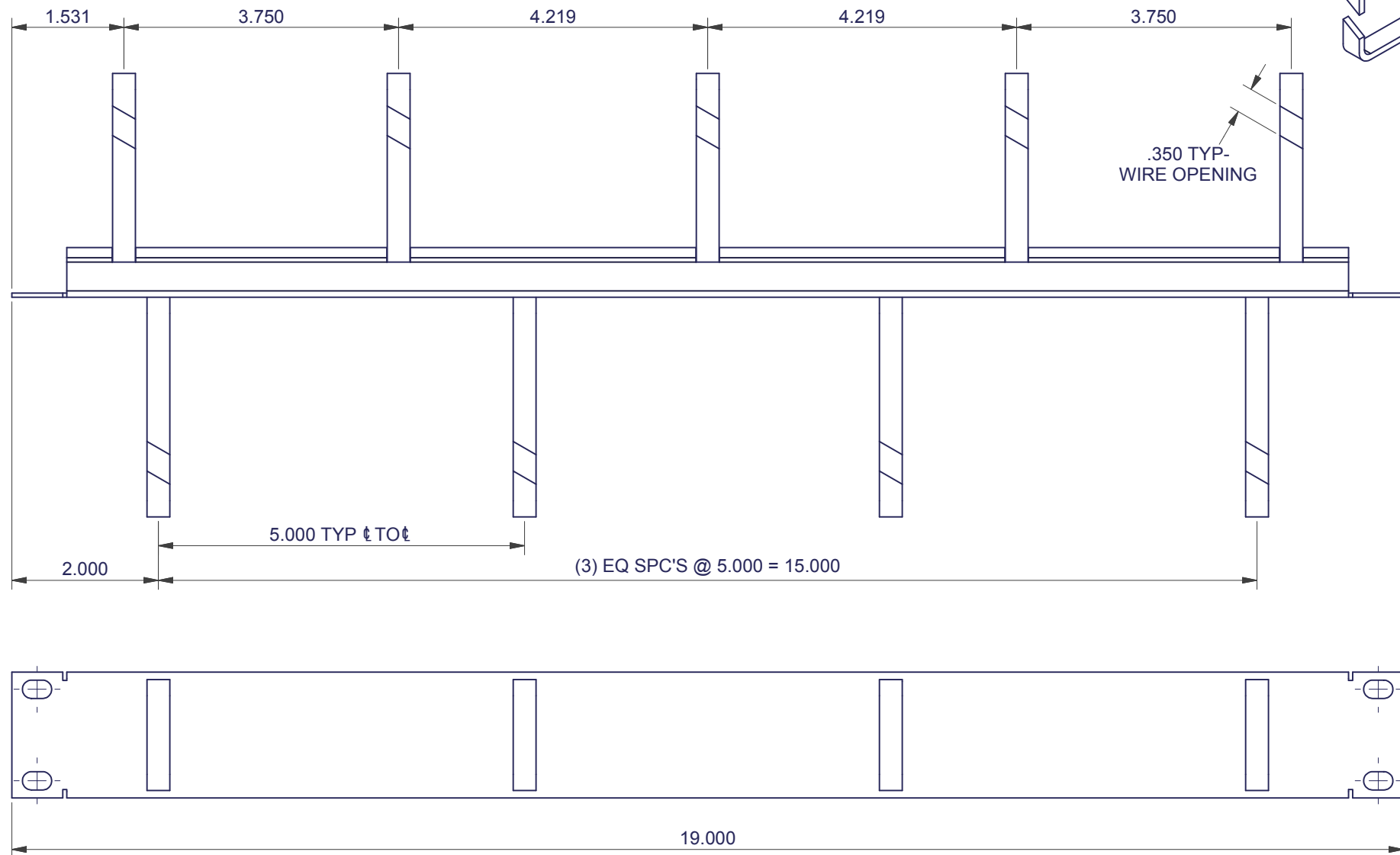

INTERPRET DRAWING PER ASME Y14.5M-1994
DIMENSIONAL LIMITS APPLY AFTER APPLICATION OF FINISH
DRAWING NOT TO SCALE
TOLERANCE UNLESS OTHERWISE NOTED:
ANGULAR +/- 1°
.XXXX +/- .010
.XXX +/- .015
.XX +/- .030
.X FOR REF. ONLY
UNLESS OTHERWISE SPECIFIED ALL DIMENSIONS ARE IN INCHES

NOTICE:
Use of this document is subject to a confidentiality and nondisclosure agreement with Great Lakes Case & Cabinet Co., Inc. (GLCC) and may not be reproduced, disclosed or utilized in whole or in part without prior written authorization from GLCC.

PART NUMBER:	CM09
QTY PER UNIT:	1
MATERIAL TYPE:	CRS
MATERIAL GAUGE:	SEE DETAILS
FINISH:	SEE NOTES
DRAWN:	DATE: 2/15/2010
FED:	DATE: 2/15/2010
CHECKED & APP.:	DATE: 2/15/2010
WSS:	

TITLE		CABLE MANAGEMENT CM09 WELDMENT/ ASSEMBLY, 19" EIA MOUNTING	
GREAT LAKES CASE & CABINET CO., INC.			
P.O. BOX 551 EDINBORO, PA 16412			
PHONE (814) 734-7303 FAX (814) 734-3907			
E-MAIL glcc@greatcabinets.com			
DWG NO:	REV	SHEET: 1 OF 1	
I011587	3		

