

Frequently Asked Questions

Adjustable ServerRack and Adjustable QuadraRack™

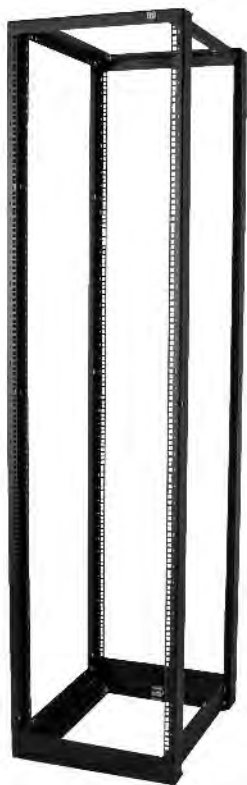

Q. What is the difference between the Adjustable ServerRack and Adjustable QuadraRack™?

A. The only difference between the Adjustable ServerRack and the Adjustable QuadraRack is the equipment mounting hole style. The Adjustable ServerRack has square mounting holes that accept cage nut hardware with various threads. Cage nuts snap into the holes allowing the threads at each rack-mount unit space to be changed to match equipment requirements. The Adjustable QuadraRack has #12-24 threaded mounting holes to accept #12-24 screws.

Q. When should I use the Adjustable ServerRack?

A. Use the Adjustable ServerRack with square equipment mounting holes in data centers and computer rooms to support rack-mount server and data storage equipment. Square-punched mounting holes let you change mounting hardware at each rack-mount unit to match equipment requirements. Rack-mount server and data storage equipment usually includes mounting rails and each type of equipment may require a different type of installation hardware.

Q. When should I use the Adjustable QuadraRack?

A. Use the Adjustable QuadraRack with #12-24 threaded equipment mounting holes in network facilities to support patch panels, fiber enclosures and network switches. This type of equipment typically attaches to the rack with a fixed mounting bracket. Threaded mounting holes speed equipment installation because a cage nut does not have to be added at each attachment point.

Q. Which rack should I use if I am using a mix of computer and network equipment or don't know what type of equipment I will place in the rack?

A. If you are not certain what type of equipment will be placed in the rack, use the Adjustable ServerRack with square equipment mounting holes. The Adjustable ServerRack will support most types of equipment.

Q. What is "adjustable" about the rack?

A. The rack is adjustable because the front and rear equipment mounting channels can be adjusted up to 5.91" (150 mm) in .98" (25 mm) increments during assembly. Adjusting the depth changes the front-to-rear mounting distance and usable depth for equipment. Once assembled the front-to-rear depth is fixed.



Q. Which "depth" rack should I use to support my equipment?

A. The Adjustable ServerRack and the Adjustable QuadraRack are available in four mounting depth ranges: 15.75" to 21.65" (400 mm-550 mm), 22.64" to 28.54" (575 mm-725 mm), 29.53" to 35.43" (750 mm-900 mm) and 36.42" to 42.32" (925 mm-1075 mm). Each range represents seven specific front-to-rear mounting channel depth settings as listed in the table on the next page. Whenever possible, channel depth should exceed equipment depth. Generally, rack-mount server equipment is at least 30" (762 mm) deep and network equipment is at least 24" (610 mm) deep. Check equipment specifications for the exact depth and mounting requirements of equipment.



CHATSWORTH PRODUCTS, INC.

+1-800-834-4969
www.chatsworth.com

Frequently Asked Questions

Adjustable ServerRack and Adjustable QuadraRack™

Part Number		Channel Depth	
Adjustable ServerRack	Adjustable QuadraRack™	in.	mm
15211-XXX	15215-XXX	15.75	400
		16.73	425
		17.72	450
		18.70	475
		19.69	500
		20.67	525
15212-XXX	15216-XXX	21.65	550
		22.64	575
		23.62	600
		24.61	625
		25.59	650
		26.57	675
15213-XXX	15217-XXX	27.56	700
		28.54	725
		29.53	750
		30.51	775
		31.50	800
		32.48	825
15214-XXX	15218-XXX	33.46	850
		34.45	875
		35.43	900
		36.42	925
		37.40	950
		38.39	975
15214-XXX	15218-XXX	39.37	1000
		40.35	1025
		41.34	1050
		42.32	1075

Note: Overall depth is channel depth +.21" (5.3 mm).

Q. Is rack-mount installation hardware included with the rack?

A. Yes, each Adjustable ServerRack includes (25) #12-24 cage nuts with screws. Each Adjustable QuadraRack includes (50) #12-24 mounting screws. You can order additional hardware with the part numbers listed in the table below.

Part Number	Description	Quantity
12637-001	Cage nuts/screws, M6	25
12638-001	Cage nuts/screws, #10-32	25
12639-001	Cage nuts/screws, #12-24	25
40605-001	Screws, #12-24, zinc	50
40605-005	Screws, #12-24, black	50

Q. The equipment mounting brackets included with my rack-mount equipment are not deep enough to span front-to-rear between the rack-mounting channels. How do I attach or place equipment in the rack?

A. Use an Adjustable ServerRack or Adjustable QuadraRack with Solid or Vented Shelves (P/N 15245-XXX or P/N 15255-XXX) or Equipment Support Rails (P/N 15235-XXX) to help

support equipment. The shelves use 1U, hold 200 lb (90.7 kg) of equipment and have mounting brackets that adjust in depth front-to-rear to match the rack. Equipment Support Rails attach to the sides of the rack, use no rack-mount units and help support up to 200 lb (90.7 kg) of equipment. Equipment Support Rails are L-shaped supports that span front-to-rear along the side of the rack and help support rack-mount equipment. The front of equipment is attached to the rack-mount channel at the front of the rack. The table below lists shelf-to-rack compatibility:

Rack		Shelf Part Number, Style, Depth Range & Description			
Part Number	Channel Depth Setting	15245-X01 (Solid) 15255-X01 (Vented) (400 mm to 550 mm) 1U, 19"EIA, 13.8"D	15245-X02 (Solid) 15255-X02 (Vented) (575 mm to 725 mm) 1U, 19"EIA, 20.7"D	15245-X03 (Solid) 15255-X03 (Vented) (750 mm to 900 mm) 1U, 19"EIA, 27.6"D	15245-X04 (Solid) 15255-X04 (Vented) (925 mm to 1075 mm) 1U, 19"EIA, 34.5"D
15211-XXX 15215-XXX	400 mm	Yes			
	425 mm	Yes			
	450 mm	Yes			
	475 mm	Yes			
	500 mm	Yes			
	525 mm	Yes			
15212-XXX 15216-XXX	550 mm	Yes			
	575 mm		Yes		
	600 mm		Yes		
	625 mm		Yes		
	650 mm		Yes		
	675 mm		Yes		
15213-XXX 15217-XXX	700 mm		Yes		
	725 mm		Yes		
	750 mm			Yes	
	775 mm			Yes	
	800 mm			Yes	
	825 mm			Yes	
15214-XXX 15218-XXX	850 mm			Yes	
	875 mm			Yes	
	900 mm			Yes	
	925 mm				Yes
	950 mm				Yes
	975 mm				Yes
15214-XXX 15218-XXX	1000 mm				Yes
	1025 mm				Yes
	1050 mm				Yes
	1075 mm				Yes

Note: Rack depth adjusts in 25 mm increments. Divide by 25.4 to find inch equivalents. All shelves will support a 200 lb (90.7 kg) load.



Frequently Asked Questions

Adjustable ServerRack and Adjustable QuadraRack™

The table below lists rails-to-rack compatibility:

Rack		Equipment Support Rails Part Number & Depth Range					
Part Number	Channel Depth Setting	15235-X01 (400 mm to 500 mm)	15235-X01 (525 mm to 625 mm)	15235-X01 (650 mm to 750 mm)	15235-X01 (775 mm to 875 mm)	15235-X01 (900 mm to 1000 mm)	15235-X01 (1025 mm to 1125 mm)
15211-XXX 15215-XXX	400 mm	Yes					
	425 mm	Yes					
	450 mm	Yes					
	475 mm	Yes					
	500 mm	Yes					
	525 mm		Yes				
15212-XXX 15216-XXX	550 mm		Yes				
	575 mm		Yes				
	600 mm		Yes				
	625 mm		Yes				
	650 mm			Yes			
	675 mm			Yes			
15213-XXX 15217-XXX	700 mm			Yes			
	725 mm			Yes			
	750 mm			Yes			
	775 mm				Yes		
	800 mm				Yes		
	825 mm				Yes		
15214-XXX 15218-XXX	850 mm				Yes		
	875 mm				Yes		
	900 mm					Yes	
	925 mm					Yes	
	950 mm					Yes	
	975 mm					Yes	
15214-XXX 15218-XXX	1000 mm					Yes	
	1025 mm						Yes
	1050 mm						Yes
	1075 mm						Yes

Note: Rack depth adjusts in 25 mm increments. Divide by 25.4 to find inch equivalents.

Q. Can I use the QuadraRack 4-Post Frame and QuadraRack Server Frame fixed shelves and accessories on the Adjustable QuadraRack or Adjustable ServerRack?

A. No, these are different products and the shelves and accessories are not compatible. The QuadraRack 4-Post Frame and the QuadraRack Server Frame are designed around a 29" D (740 mm) rack footprint. The Adjustable QuadraRack and Adjustable ServerRack are metric footprint racks designed around stepped 25 mm changes from 400 mm to 1075 mm in depth.

Q. Are there other shelves that can be used with the Adjustable ServerRack and Adjustable QuadraRack?

A. Yes, you can use the Extra Heavy Duty Sliding Shelf (P/N 12700-X19), 32" D (810 mm) Sliding Shelf (P/N 11913-X19 and P/N 11914-X19) and several cabinet Sliding Shelves (P/N 12338-X19, P/N 12339-X19, P/N 12345-X19 and P/N 12346-X19) with the Adjustable ServerRack and Adjustable QuadraRack. The table below lists shelf-to-rack compatibility.

Rack		Shelf Part Number, Style, Depth Range & Description			
Part Number	Channel Depth Setting	12700-X19 (Solid) (510 mm to 860 mm) 2U, 19" EIA, 26" D 300 lb/136 kg capacity	11913-X19 (Vented) 11914-X19 (Solid) (810 mm) 2U, 19" EIA, 32" D 160 lb/72.5 kg capacity	12338-X19 (Solid) 12339-X19 (Vented) (460 mm to 760 mm) 2U, 19" EIA, 18" D 140 lb/63.5 kg capacity	12345-X19 (Solid) 12346-X19 (Vented) (360 mm to 610 mm) 2U, 19" EIA, 24" D 140 lb/63.5 kg capacity
15211-XXX 15215-XXX	400 mm			Yes	
	425 mm			Yes	
	450 mm			Yes	
	475 mm			Yes	Yes
	500 mm			Yes	Yes
	525 mm	Yes		Yes	Yes
15212-XXX 15216-XXX	550 mm	Yes		Yes	Yes
	575 mm	Yes		Yes	Yes
	600 mm	Yes		Yes	Yes
	625 mm	Yes			Yes
	650 mm	Yes			Yes
	675 mm	Yes			Yes
15213-XXX 15217-XXX	700 mm	Yes	Yes		Yes
	725 mm	Yes	Yes		Yes
	750 mm	Yes	Yes		Yes
	775 mm	Yes	Yes		
	800 mm	Yes	Yes		
	825 mm	Yes	Yes		
15214-XXX 15218-XXX	850 mm	Yes	Yes		
	875 mm	Yes	Yes		
	900 mm	Yes	Yes		
	925 mm	Yes	Yes		
	950 mm	Yes	Yes		
	975 mm	Yes	Yes		
15214-XXX 15218-XXX	1000 mm	Yes	Yes		
	1025 mm	Yes	Yes		
	1050 mm	Yes	Yes		
	1075 mm	Yes	Yes		

Note: Rack depth adjusts in 25 mm increments. Divide by 25.4 to find inch equivalents.



Frequently Asked Questions

Adjustable ServerRack and Adjustable QuadraRack™

Q. When should you use a Center Rail?

A. Adjustable QuadraRack (AQR) and Adjustable ServerRack (ASR) provide front and rear support for equipment with two fixed pairs of equipment mounting rails located at the front and rear of the rack. The corner posts of the rack are the mounting rails and are fixed in place (depth) once the rack is assembled and installed. In many instances, one depth of rack will work because most four-post rack-mount equipment includes adjustable depth mounting rails. However, in some instances, customers may require a third pair of equipment rails positioned between the front and rear of the rack to provide support for other equipment or shelves. Use Center Rail (P/N 15330-XXX or 15335-XXX) whenever a third pair of equipment mounting rails is required. Center Rail is particularly useful in the deepest racks because these racks exceed the mounting depth of typical four-post rack-mount equipment.

Q: Does the Center Rail reduce the load bearing capacity of the rack?

A. No, the Center Rail (P/N 15330-XXX or 15335-XXX) does not reduce the load bearing capacity of the rack. Adjustable QuadraRack (AQR) and Adjustable ServerRack (ASR) have a 2,000 lb (907.2 kg) equipment load bearing capacity. Center Rail has a 1,000 lb (453.6 kg) load bearing capacity. When Center Rail is added to a rack, the total load bearing capacity of the rack remains 2,000 lb (907.2 kg), but no more than 1,000 lb should be placed on the Center Rail. So, you can support up to 2,000 lb (907.2 kg) of four-post equipment when one side is attached to the rack and one side is attached to the Center Rail or you can support up to 1,000 lb (453.6 kg) if equipment is only attached to Center Rail.

Q. Can the Adjustable ServerRack and Adjustable QuadraRack be assembled into multi-rack bays?

A. Yes, the Adjustable ServerRack and Adjustable QuadraRack have the same side hole pattern as the Standard Rack, Universal Rack, 6"D (150 mm) Standard Rack, QuadraRack 4-Post Frame and QuadraRack ServerFrame and can be bayed together with these racks to create a multi-rack bay. Use the Rack Line-Up Spacer Kit (P/N 40702-X00 for Standard and Universal Racks or P/N 16342-X02 for QuadraRacks) to connect the racks together side-by-side.

Q. Can CPI vertical cable managers be used with the Adjustable ServerRack and Adjustable QuadraRack?

A. Yes, the Adjustable ServerRack and Adjustable QuadraRack have the same side hole pattern as CPI's Standard Rack, Universal Rack, 6D (150 mm) Standard Rack, QuadraRack 4-Post Frame and QuadraRack Server Frame and can be used with all CPI vertical cabling sections and managers; VCS Vertical Cabling Sections, MCS Master Cabling Sections, CCS Combination Cabling Sections, Evolution™ Cable Management and Velocity™ Cable Management. The cable manager and rack must be the same height and can be used in between racks in a multi-rack bay to create vertical cable pathways between racks.

Q. Can CPI horizontal cable managers be used with the Adjustable ServerRack and Adjustable QuadraRack?

A. Yes, the racks support 19" wide EIA equipment. All CPI 19"W horizontal cable managers including the Universal Horizontal Cable Manager, 19" Horizontal Wire Management Panel, Large Horizontal Ring Panel, Rack Cabling Managers, Jumper Trays, Evolution™ or Velocity™ Cable Management will attach to the Adjustable ServerRack and Adjustable QuadraRack. CPI recommends planning 1U of horizontal cable management space for every 2U of connectivity.

Q. Can CPI Cable Runway (ladder rack) be attached directly to the top of the Adjustable ServerRack and Adjustable QuadraRack?

A. Yes, certain sizes of cable runway can attach directly to the top of the racks with a J-Bolt Kit (P/N 11308-X01) or a Cable Runway Elevation Kit (P/N 10506-X02 or 10506-X06) as indicated in the tables below. As an alternative, the Cable Runway Mounting Bracket (P/N 15205-X01) can be used to attach Cable Runway 6" to 24"W (150 mm - 610 mm) to the top of the racks in either the perpendicular (front-to-back) or parallel (side-to-side) orientation.

Part Number Depth Range - (mm) Perpendicular	Width of Cable Runway - in (mm)							
	6 (150)	9 (230)	10 (250)	12 (300)	15 (380)	18 (460)	20 (510)	24 (610)
15211-XXX, 15215-XXX (400 - 550)	•	•	•	•	•	•		
15212-XXX, 15216-XXX (575 - 725)	•	•	•	•	•	•		
15213-XXX, 15217-XXX (750 - 900)	•	•	•	•	•	•		
15214-XXX, 15218-XXX (925 - 1075)	•	•	•	•	•	•		



Frequently Asked Questions

Adjustable ServerRack and Adjustable QuadraRack™

Parallel Orientation (Side-to-Side)								
Part Number Depth Range - (mm) Parallel	Width of Cable Runway - in (mm)							
	6 (150)	9 (230)	10 (250)	12 (300)	15 (300)	18 (460)	20 (510)	24 (610)
15211-XXX, 15215-XXX (400 to 550)	•	•	•	•				
15212-XXX, 15216-XXX (575 mm to 725 mm D)	•	•	•	•	•	•		
15213-XXX, 15217-XXX (750 mm to 900 mm D)	•	•	•	•	•	•	•	•
15214-XXX, 15218-XXX (925 mm to 1075 mm D)	•	•	•	•	•	•	•	•

Q. Do the Adjustable ServerRack and Adjustable QuadraRack deliver assembled or unassembled?

A. The Adjustable ServerRack and Adjustable QuadraRack are delivered unassembled.

Q. How long does it take to assemble an Adjustable ServerRack or an Adjustable QuadraRack?

A. It takes one person approximately 20 minutes to assemble each rack. The Adjustable ServerRack and Adjustable QuadraRack are delivered unassembled in a single carton. The rectangular front and rear rack-mount frames are welded. There are four side brackets that attach at the corners of the frames. Each rack can adjust up to 5.91" (150 mm) in depth front-to-rear in .98" (25 mm) increments during assembly. Depth adjustments are made at the corners by selecting the appropriate set of assembly holes in the side bracket to determine overall front-to-rear depth of the rack. There are three bolts in each bottom corner and two bolts in each top corner. Carriage bolts are used to assemble the rack so a single wrench is all that is required.

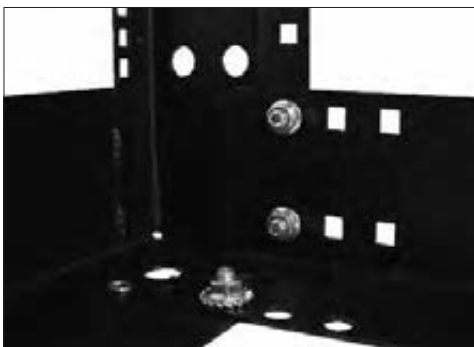

Note: The rack includes 8 mm assembly hardware. Use a 13 mm (1/2") wrench or an adjustable wrench to assemble the rack.

Q. Is the rack base pre-punched with floor installation holes?

A. Yes, the rack base is pre-punched with floor installation holes. A pair of holes is located at the front and rear of the rack frame. The hole centers are 16" (406.4 mm) wide. The front-to-rear distance between the holes is the channel depth minus 3.28" (83.3 mm). Install the rack on concrete slab floors with the Rack Installation Kit (P/N 40604-003) and on wood floors with the Rack Installation Kit (P/N 40607-001). Use 3/8" or M10 threaded rods to attach the rack to the finished floor in raised access floor environments.

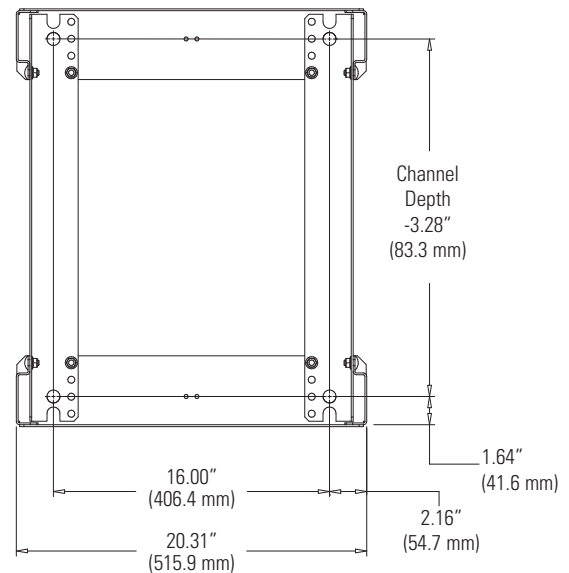

Q. How do I bond the Adjustable ServerRack or Adjustable QuadraRack to the Telecommunications Grounding Busbar?

A. The Adjustable ServerRack and Adjustable QuadraRack have a pair of threaded studs pressed into the front and rear base of the frame. The area around the studs is masked. Each rack includes a Two Mounting Hole Ground Terminal Block (P/N 40167-001) and Antioxidant Joint Compound. Remove the masking, apply the joint compound and install the ground terminal block with included hardware. Then attach an appropriately sized ground conductor (not included) from the ground terminal block to the Telecommunications Grounding Busbar or signal reference grid.