

Installation Instructions

ADJUSTABLE SERVERRACK AND QUADRARACK

Safety Information



WARNING: To reduce the risk of personal injury or damage to equipment, the rack must be bolted to the floor. Two or more racks can be bayed to enhance stability, but they must still be anchored to the floor.



WARNING: Improper use of this product may lead to serious injury or death. Read and understand all instructions for proper installation and use of this product.



WARNING: Be sure to use sufficient personnel to safely assemble and install the rack.



WARNING: Do not load equipment into the rack prior to it being bolted to the floor, as it could tip over.



WARNING: For protection of the equipment and personnel, ground each rack individually to a busbar or signal reference grid.

Always load heavier equipment, such as a UPS, at the bottom of the rack. Extend only one server at a time. Unload equipment from the rack before moving it.

Intended Use

Install this rack only in a restricted service environment, such as a data center. Use indoors only, in environmentally controlled areas; do not use outdoors, in harsh environments or in air-handling spaces. Use this rack for computer equipment, including servers and peripherals. Allow only qualified service personnel to use this rack.

Tools Required

10mm open end wrench
13mm socket wrench
Pliers (to install cage nuts in Adjustable ServerRack)

Included Hardware

12 each
8 mm x
16 mm Bolt



20 each
8mm
Flange Nut



8 each
8mm
Lock Washer



2 each
6mm Lock Nut



1 each
Grounding Block

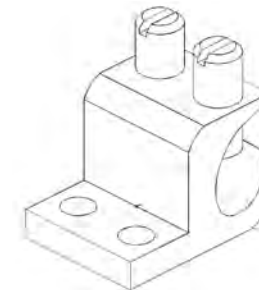

1 tube Antioxidant Compound

50 each 12-24 x 5/8 Screws, For QuadraRack only

25 each 12-24 Cage Nuts, For ServerRack only



CHATSWORTH PRODUCTS, INC.

IIS-715210, 01/15/07, Rev. 1, CPI/B Krietzman
800-834-4969 • techsupport@chatsworth.com • www.chatsworth.com

This drawing contains proprietary and confidential information and is protected by U.S. and international law. Unauthorized reproduction, disclosure or use of the drawing or the information therein is expressly forbidden except as agreed to in writing by Chatsworth Products, Inc.

Installation Instructions

ADJUSTABLE SERVERRACK AND QUADRARACK

Assembly Sequence

1. Lay one frame down on the floor with the rear flange facing up.
2. Determine the mounting position of the connecting brackets using the chart shown below. First find the desired rack depth in the chart that corresponds to the rack part number. The letter to the right of the depth is the hole position to use.

	RACK PART NUMBER					HOLE POSITION
	15211	15212	15213	15214		
	15215	15216	15217	15218		
RACK DEPTH (mm)	400	575	750	925	A	
	425	600	775	950	B	
	450	625	800	975	C	
	475	650	825	1000	D	
	500	675	850	1025	E	
	525	700	875	1050	F	
	550	725	900	1075	G	

The letter is stamped in the bracket adjacent to the hole to be used. Position the bracket with the indicated hole on the bracket stud. For example if a 400 mm depth rack is desired, the brackets would use all holes marked with an "A". The picture below shows the base stud at the "A/B" hole.

3. Install the two base brackets to the frame. Use an 8 mm star lock washer and 8 mm nut on each stud. Important: the star washer must be used to ensure electrical bonding throughout the entire rack frame. Install two 8 mm x 16 mm bolts and 8 mm nuts through the rear frame flange. Do not fully tighten the nuts, leave them finger tight..

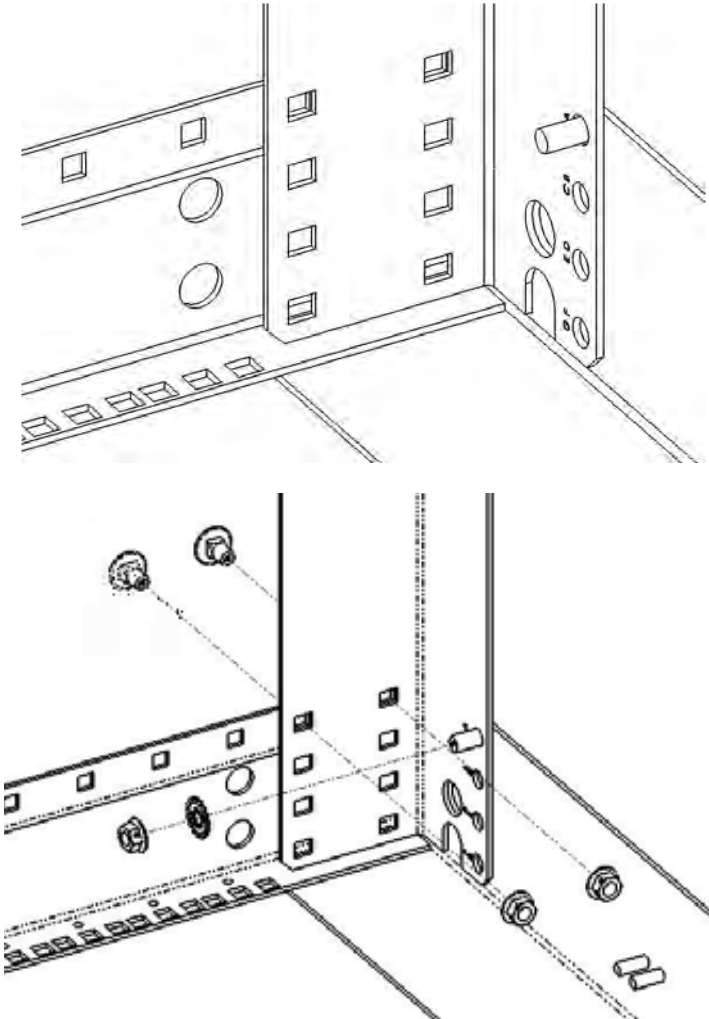

Installation Instructions

ADJUSTABLE SERVERRACK AND QUADRARACK

4. Turn the assembly onto its side. Attach the remaining frame to the base angles. Be sure to use the same mounting holes from step 2. Leave hardware finger tight.

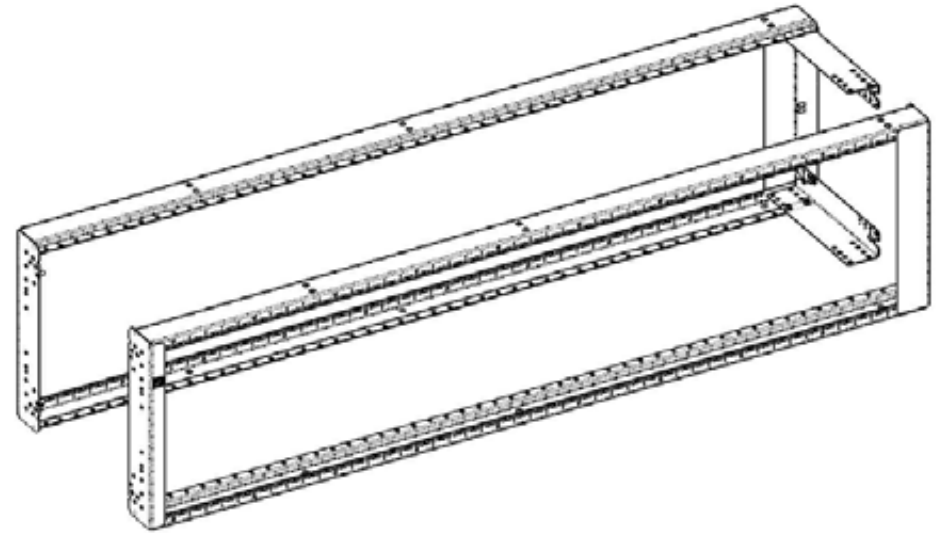

5. Attach the two top angles in the same way as the base angles. Again, be sure to use the same lettered mounting holes as the base. Use an 8 mm star lock washer and 8 mm nut on each stud. Important: the star washer must be used to ensure electrical bonding throughout the entire rack frame. Only one 8 mm x 16 mm bolt and 8 mm nut are used at each end of the angle to attach to the rear frame flange.

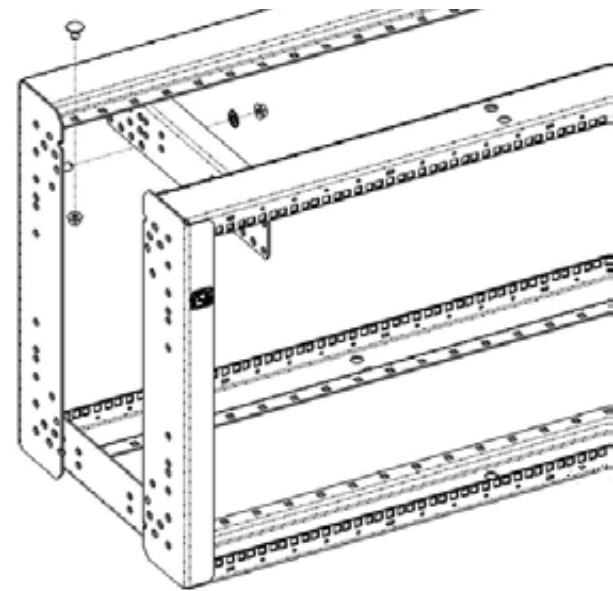

6. Tighten all nuts at the base and top. The rack can now be stood up on its base.

Installation Instructions

ADJUSTABLE SERVERRACK AND QUADRARACK

7. Optional grounding block mounting: The grounding block can be mounted to the base of either the front or rear frame. Remove the paint masking material from around the two mounting studs. Apply supplied Antioxidant Joint Compound to exposed steel area. Mount the block to the studs with two 6 mm lock nuts

