

QuickPort® eXtreme® CAT 6A High-Density Shielded Connector

APPLICATION

Leviton CAT 6A shielded products are designed to support all 10GBase-T networks. Leviton CAT 6A shielded connectors meet TIA-568-C.2 (CAT 6A) and ISO/IEC 11801 (Class EA) requirements for all internal and Alien Crosstalk parameters up to 500 MHz. The shielded connector provides superior Alien Crosstalk suppression and protects critical data from potential EMI/RFI (electromagnetic interference/ radio frequency interference). The connector is part of a complete CAT 6A shielded system ideal for government, healthcare, manufacturing, transportation, gaming, and other environments where EMI/RFI may be a concern.



front view



rear view

SPECIFICATION

CAT 6A shielded connector shall provide electrical TIA-568-C.2 (Augmented CAT 6) and ISO/IEC 11801 (Class EA) performance for all internal and alien crosstalk parameters up to 500 MHz. Up to six connectors shall be able to fit in a single-gang faceplate for high density applications. The connector shall be encased in a die-cast housing with a wide angle, hinged design that allows easy access for termination. The connector shall allow termination without a 110 punch down tool. The connector shall include T568A and T568B universal color codes.

FEATURES

- Backwards compatible to support CAT 6 and CAT 5e performance
- Provides seamless migration from 1000Base-T to 10GBase-T network performance
- Shielding provides EMI/RFI protection, signal isolation, and excellent alien crosstalk (AXT) suppression
- Connector features robust die-cast housing
- Unique design requires no punch-down tool
- Connector incorporates a wide-angle, hinged design for easy access and termination
- Supports CAT 6A performance in short permanent link applications

DESIGN CONSIDERATIONS

- Can be used to terminate all types of shielded cable
- Use flush cut trimmers to remove exposed conductors prior to termination
- Fits most Leviton Quickport applications in patch panels, faceplates and surface mount boxes

STANDARDS COMPLIANCE

Connector is part of a complete CAT 6A shielded solution that meets the following standards:

- TIA-568-C.0
- TIA-568-C.1
- TIA-568-C.2 CAT 6A
- ISO 11801 Class E_a
- IEEE 802.3an 10GBASE-T
- IEEE 802.3af Power over Ethernet (PoE)
- IEEE 802.3at Power over Ethernet Plus (PoE+)
- FCC Part 68
- EN 50173

PHYSICAL SPECIFICATIONS

Dimensions: See page two

WARRANTY INFORMATION

For a copy of Leviton product warranties, visit www.leviton.com.

ELECTRONIC FILES

For CAD files, typical specs, or dimensional line art. (.DXF, .DWG, Visio), visit www.leviton.com.

TIA-568-C.2 CAT 6A CHANNEL PERFORMANCE

Frequency	Channel IL	Channel NEXT	Channel PS NEXT	Channel ACRF	Channel PSACRF	Channel RL	CH PSAACRF	AVE CH PSAACRF	CH and PL PSANEXT IL>7	AVE CH and PL PSANEXT IL>7
1	2.3	65.0	62.0	63.3	60.3	19.0	67.0	67.0	67.0	67.0
4	4.2	63.0	60.5	51.2	48.2	19.0	65.0	67.0	67.0	67.0
8	5.8	58.2	55.6	45.2	42.2	19.0	58.9	62.9	67.0	67.0
10	6.5	56.6	54.0	43.3	40.3	19.0	57.0	61.0	67.0	67.0
16	8.2	53.2	50.6	39.2	36.2	18.0	52.9	56.9	67.0	67.0
20	9.2	51.6	49.0	37.2	34.2	17.5	51.0	55.0	67.0	67.0
25	10.2	50.0	47.3	35.3	32.3	17.0	49.0	53.0	66.0	67.0
31.25	11.5	48.4	45.7	33.4	30.4	16.5	47.1	51.1	65.1	67.0
62.5	16.4	43.4	40.6	27.3	24.3	14.0	41.1	45.1	62.0	64.3
100	20.9	39.9	37.1	23.3	20.3	12.0	37.0	41.0	60.0	62.3
200	30.1	34.8	31.9	17.2	14.2	9.0	31.0	35.0	55.5	57.7
250	33.9	33.1	30.2	15.3	12.3	8.0	29.0	33.0	54.0	56.3
300	37.4	31.7	28.8	13.7	10.7	7.2	27.5	31.5	52.8	55.1
400	43.7	28.7	25.8	11.2	8.2	6.0	25.0	29.0	51.0	53.2
500	49.3	26.1	23.2	9.3	6.3	6.0	23.0	27.0	49.5	51.8

6ASHD-S6A

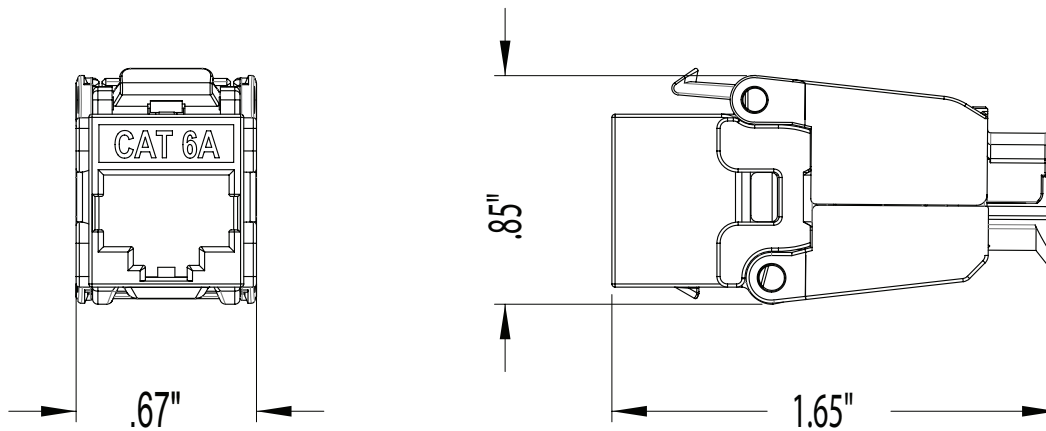

PART NUMBERS

Description	Part No.
QuickPort® CAT 6A Shielded Connector	6ASHD-S6A



Leviton Network Solutions
2222 - 222nd St. SE
Bothell, WA 98021-4416

Asia / Pacific
T +1.631.812.6228
E infoasean@leviton.com

Canada
T +1.514.954.1840
E pcservice@leviton.com

Caribbean
T +1.954.593.1896
E infocaribbean@leviton.com

China
T +852.2774.9876
E infochina@leviton.com

Colombia
T +57.1.743.6045
E infocolombia@leviton.com

tel 1-800-824-3005
tel +1-425-486-2222
appeng@leviton.com
www.leviton.com

Europe
T +33.6.8869.1380
E infoeurope@leviton.com

India / SAARC
T +91.80.4322.5678
E infoindia@leviton.com

Mexico
T +52.55.5082.1040
E lsamarketing@leviton.com

Middle East & Africa
T +971.4.886.4722
E lmeinfo@leviton.com

South Korea
T +82.2.3273.9963
E infokorea@leviton.com