



Fusion Pressurized Housings

Pressurized and Dust-Proof Tubular Environmental Camera Housings

The Fusion Pressurized and Dust-Proof Housings for fixed cameras are engineered with camera protection, ease of installation and true flexibility in mind. The Moog “elegantly simple by design” philosophy ensures affordability in the finished product.

The Fusion tubular housing body is constructed of treated aircraft-grade aluminum and 316 stainless steel hardware to ensure camera protection in harsh, corrosive environments. Pressurization protects the camera and lens from debris, chemicals and other contaminants, extending the life of the camera and reducing service calls. Each pressurized unit includes a 16-pin hermetically-sealed connector to simplify connections. A heavy-duty feed through wall / pole mount, with conduit input, protects and conceals wiring.

Fusion Pressurized Housings are potentially the easiest pressurized enclosure to install and maintain on the market. Easy access to the camera and all serviceable parts allows service to be performed while the camera position and viewing angle are maintained. Other easy-to-install features include: a camera sled that can be rotated within the housing to ensure the desired field of view; a rear endcap that allows for easy wire installation through the mount; and a simple plug-in connection board.

Flexible features include: 12/24v or PoE Plus option, with patent pending Dynamic Power Allocation™ (DPA); and distinct models offering dust proof or pressurization to meet required levels of protection.

Available Features

- Powder coated aluminium and 316 stainless steel hardware
- Thermostatically controlled heater, with continuous blower
- Meets IP67 and NEMA Type 4 standards
- 5-7psi pressure relief valve eliminates over pressurization
- Schraeder valve to fill the housing with Nitrogen or another clean stable gas
- Standard wall / pole mount (no pole adapters needed)
- IK10 vandal resistant (model available upon request)
- PoE or 12/24v input model
- PoE Ready™ models:
 - PoE Plus IEEE802.3at compliant device, compatible with any PoE IEEE802.3af camera
 - True PoE power to the camera (no splitter needed for camera)
 - DPA ensures maximum power to the camera with remaining power provided to the H&B
 - Automatically adjusts to power loss for long cable runs



PFH10

Models:

PFH10C2W

Pressurized tubular housing, 24Vac or 12Vdc input, heater & blower with feed-thru wall / pole mount

PFH10C2WY

Pressurized tubular housing, 24Vac or 12Vdc input, heater & blower with feed-thru wall / pole mount, adjustable sunshield

PFH10C8W

Pressurized tubular housing, PoE input with Dynamic Power Allocation, 30 watt midspan included, heater & blower with feed-thru wall / pole mount, supports .af PoE cameras, adjustable sunshield

DFH10C2W

Dust-Proof tubular housing, 24Vac or 12Vdc input, heater & blower with feed-thru wall / pole mount

DFH10C2WY

Dust-Proof tubular housing, 24Vac or 12Vdc input, heater & blower with feed-thru wall / pole mount, adjustable sunshield

DFH10C8W

Dust-Proof tubular housing, PoE input with Dynamic Power Allocation, 30 watt midspan included, heater & blower with feed-thru wall / pole mount, supports .af PoE cameras, adjustable sunshield

Multiple Options For Camera Access:

- 1 FRONT LENS: Remove front cover for lens adjustment
- 2 MAIN BODY: Remove to access the camera
- 3 REAR: Loosen cover and rotate to access the wiring
- 4 MOUNTING BRACKET: Remove entire enclosure from mount while maintaining camera positioning, to send in for maintenance and servicing

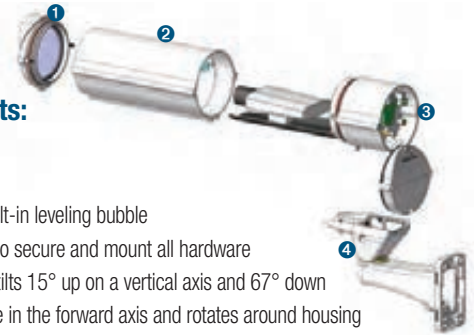

Available Benefits:

- Easy installation
- PED compliant
- Camera sled has a built-in leveling bubble
- Only one tool needed to secure and mount all hardware
- The wall mount pan / tilts 15° up on a vertical axis and 67° down
- Sunshield is adjustable in the forward axis and rotates around housing
- Front window with standard model glass, options for alternate coating and material

General Specifications	
Max Camera Length:	10" (250mm)
Mounting Style:	Wall or Pole (STANDARD)
Product Dimensions:	20" x 12" x 6" (510 x 305 x 153mm)
Product Weight:	10 lbs (4.6 Kg) (WITH MOUNT AND SUNSHIELD)

Electrical Specifications		
Input Voltage:	PoE or 12/24v input model	
Power Consumption	24Vac:	29 watts: Heater & Blower
	12Vdc:	11 watts: Heater & Blower
	PoE:	25 watts: Camera, Blower & Heater
Power Output	24/12v:	Same as input, minus power for Heater & Blower
	PoE:	IEEE802.3af

Shipping Specifications		
Model	Shipping Weight	Box Dimensions
PFH10 Series:	11 lbs (EST.)	8.25" x 11.75" x 19.5" (209 x 298 x 495mm)

Environmental Specifications	
Blower:	Yes (Continuous)
Effective Projected Area (EPA):	99 square inches (including wall mount)
Heater:	Yes
Heater Activates at:	60°F (15.5°C)
Heater Deactivates at:	80°F (27°C)
IP Rating (Weather Rating):	IP67
Maximum Windload:	150 mph (240 kph)
Operating Temperature-Ambient:	-58°F to 158°F (-50°C to 70°C)

Mechanical Specifications	
Construction Body:	Aluminum, all hardware is 316 stainless steel
Construction Endcaps:	Front: Cast aluminum; Rear: Plastic
Mounting Bracket Construction:	Cast aluminum
Mounting Pattern (W x H):	2" x 4.25" (51 x 108mm)
Pressure Relief Valve:	5-7 psi (Pressurized models only)
Schraeder Valve:	Yes (Pressurized models only)
Viewing Window Construction:	Tempered Glass

Architectural Drawings

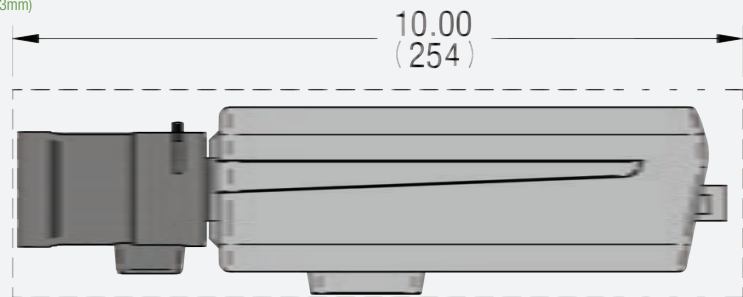
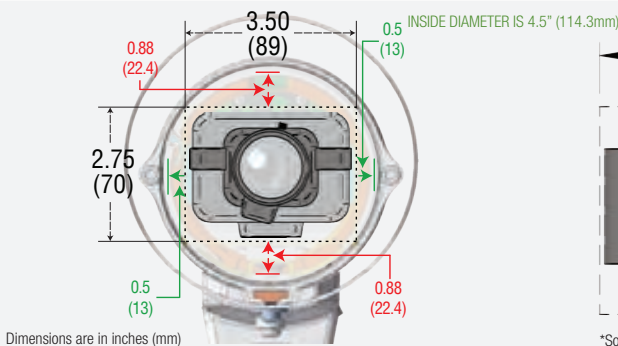

*Some cameras outside of the shown dimensions may be compatible with this housing. Contact Moog for assistance.

Regulatory and Certifications



MOOG

Sensor and Surveillance Systems