

CABLERACK™



INDUSTRY STANDARDS

UL 1863 Listed; File Number E230874
 Rated to 60 lbs. with a 4X safety factor

EIA 310-D

APPLICATION

CABLERACK™ is used for ladder or basket tray mounting and securing 19-inch rack equipment for Data centers, Telecommunication rooms and other locations. The fixed, open frame rack allows suspending 19-inch rack equipment from Ladder Rack or Basket Tray. The rack has universal tapped holes per industry standards to accommodate typical applications. These open frame racks are ideal for high-density cabling applications which require above-the-cabinet mounting of equipment, and provide maximum access to cables and equipment. CABLERACK is ideal for Data Center applications, expanding equipment to above-the-cabinet while providing increased equipment and cable densities.

FEATURES

- Designed to accommodate all standard 19-inch rack equipment
- Easy, single-tool assembly reduces installation time and cost
- Preamsembled for fast, time-saving installation
- Securely mounts to either Cable Runway (Ladder Rack) or Basket Tray
- UL double lug ground holes provide easy adherence to local bonding and grounding codes
- Cable tie down points, sized for up to 1-inch Velcro® straps, provided in horizontal and vertical positions in multiple locations
- Parallel or perpendicular mounting to cable pathway

- Multi-point mounting provisions address various application needs
- Open design provides for maximum access to cables and equipment
- Smart packaging with hand-carrying holes allow for easy transportation

SPECIFICATIONS

- Wall section made of heavy gauge cold rolled steel welded construction
- Side supporting fingers made of composite material with black finish
- Tapped holes (12-24UNC) per EIA Universal pattern standard (1/4-5/8-5/8-1/4)

FINISH

- Pretreated steel coated with RAL 9005 black textured, low-gloss polyester powder paint
- Hardware is clear or plated black

LOAD RATING

Static load rating is 100 lbs.

ACCESSORIES

- Cable Bend Radius Accessory
- Blanking Panels
- Grounding kits
- PDUs
- Shelves

BULLETIN: DOFRW

Standard Product

Catalog Number	AxBxC in./mm	Rack Units	Cable Bend Radius Accessory
E19T6U	12.44 x 20.16 x 11.50 316 x 512 x 292	6	ECMBA4

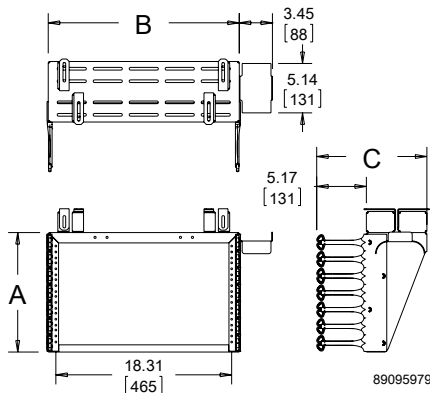

CABLERACK™ CABLE BEND RADIUS ACCESSORY



CABLERACK™ has a complimentary cable bend radius accessory which easily attaches to multiple locations on the rack. Each kit includes four bend radius brackets and mounting hardware.

BULLETIN: DOFRW

Standard Product

Catalog Number	AxBxC in./mm	Use With
ECMBA4	2.24 x 5.16 x 3.46 57 x 131 x 88	E19T6U