



### 1. SAFETY PRECAUTIONS

#### 1.1. Confined Space Precaution

 **WARNING:** Follow all OSHA regulations concerning confined space entry and work.

#### 1.2. Lead Exposure Warning

 **WARNING:** Lead dust may be released into the manhole atmosphere any time the sheath of older lead sheath cable is disturbed. When working in manholes, precautions must be taken to limit the amount of exposure to lead. Strictly observe your company's lead handling procedures to eliminate this hazard. Failure to do so may result in serious, long-term health problems.

#### 1.3. Cable Handling Precautions

 **CAUTION:** Care must be taken to avoid cable damage during handling and placing. Fiber optic cable is sensitive to excessive pulling, bending, and crush forces. Any such damage may alter the cable's characteristics to the extent that the cable section may have to be replaced. To ensure all specifications are met, consult the specific cable specification sheet for the cable you are installing.

**1.4.** Corning Cable Systems' cable specification sheets are available which list the maximum tensile load for various cable types. The maximum pulling tension for stranded loose tube cable and ribbon cable is 600 lb<sub>F</sub> (2,700 Newtons).

**1.5.** Corning Cable Systems' cable specification sheets also list the minimum cable bend radius both "Loaded" (during installation) and "Installed" (after installation). If these sheets are not available on the job-site, the following formulas may be used to determine general guidelines for installing Corning Cable Systems' fiber optic cable:

To arrive at a working bend radius for cable installation, multiply 15 times (15 x) the cable outside diameter.

Example:

Cable Diameter = 0.46 in (11.8 mm)

15 x 0.46 in = 6.9 in (177 mm)

Minimum Working Bend Radius = 6.9 in (17.7 cm)

To find the minimum diameter requirement for pull wheels or rollers, simply double the minimum working bend radius.

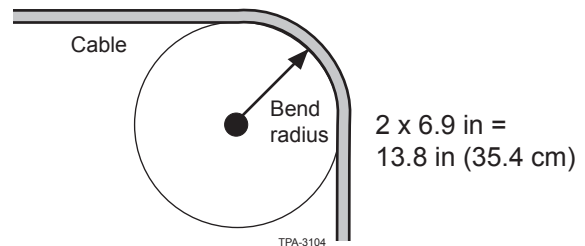

**1.6.** Whenever unreeled cable is placed on the pavement or surface above a manhole, provide barricades or other means of preventing vehicular or pedestrian traffic through the area.

**1.7.** The figure-eight configuration should be used to prevent kinking or twisting when the cable must be unreeled or backed.

Fiber optic cable should not be coiled in a continuous direction except for lengths of 100 ft (30 m) or less. The preferred size for the figure-eight is about 15 ft (4.5 m) in length, with each loop 5 ft (1.5 m) to 8 ft (2.4 m) in diameter.

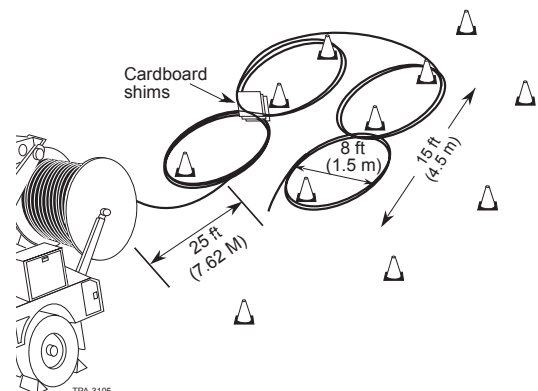



**2.6.** Factors to consider in developing the pull plan include changes in elevation and the locations of bends and offsets.

- For ease of installation, pull cables from higher elevation manholes to lower ones, whenever possible.
- Bends describe pronounced turns in the routing of a duct system.
- Offsets in a duct system are more gradual variations from the ideal, straight path of a duct section. Offsets can impose greatly increased pulling tension.

For example, a three foot offset in a 10-foot run of duct can add an estimated 120 lb<sub>F</sub> of tension to a pull<sup>1</sup>.

To minimize the effect of bends and offsets, begin such pulls at the end of the innerduct section nearest the difficult area.

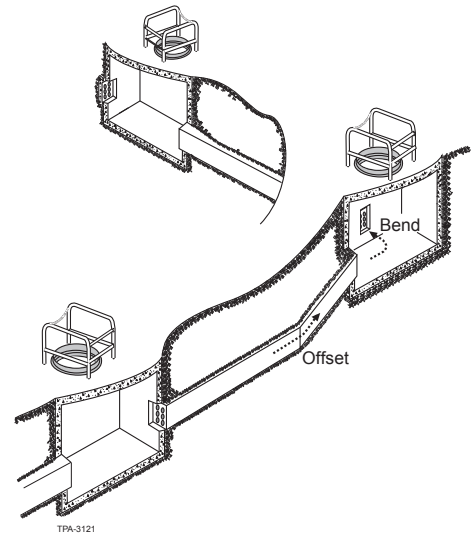

<sup>1</sup>John Anderson, "Assist Device Proves Itself In Long F O Pulls" Outside Plant, March 1986, p 40.

### 3. INSTALLATION EQUIPMENT AND ACCESSORIES

#### Innerduct

**3.1.** Innerduct is a way to subdivide the duct and to provide for future cable pulls. Three 1.25-inch inside diameter (I.D.) innerducts can usually be pulled into a 4-inch duct. Proper size and installation of the innerduct is critical for ease of cable installation.

**3.2.** Innerduct is available in ribbed, corrugated, and smooth-walled constructions of polyethylene or PVC material. Corning Cable Systems' fiber optic cable is compatible with all major brands of innerduct. Consult your company's practices for innerduct specifications.

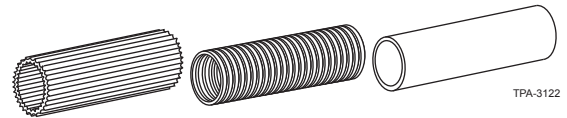

**3.3.** Fill ratios are calculated by comparing the area of an inner diameter cross-section of the innerduct to the outer diameter cross-section area of the fiber optic cable. Larger diameter innerducts (which result in smaller fill ratios) will normally reduce pulling tension.

To calculate a fill ratio, use the following formulas from the chart. For a quick calculator, see [www.corning.com/cablesystems/fillratio](http://www.corning.com/cablesystems/fillratio)

**3.4.** Multiple cables may be pulled simultaneously into one innerduct. Pulling a new fiber optic cable over an existing one is not recommended due to the possibility of entanglement.

Formulas Used to Calculate Fill Ratio		
First Cable	Second Cable	Third Cable
$\frac{d^2}{D^2} < 65\%$	$\frac{d_1^2 + d_2^2}{D^2} \leq 31\%$	$\frac{d_1^2 + d_2^2 + d_3^2}{D^2} \leq 40\%$
<b>Legend</b> d = Cable Diameter d <sub>1</sub> = First Cable Diameter d <sub>2</sub> = Second Cable Diameter d <sub>3</sub> = Third Cable Diameter D = Innerduct Diameter		

**3.5.** Should an innerduct become twisted during installation, the twisting (helixing) can dramatically increase pulling tension during cable installation. Corrugated innerduct has less "memory" than other types of innerduct, and may tend to lay flatter in the duct.

**3.6.** Innerduct often stretches during installation. Allowance must be made for the relaxation of this stretch by planning for extra slack to be pulled into manholes.

**3.7.** At points where innerduct will be continuous through a manhole, allow sufficient slack so that the innerduct may be secured on the manhole racks and maintain the cable's minimum bend radius.

**3.8.** At points where the innerduct is not continuous through a manhole, some provision must be made to provide a section to cover the cable in the manhole during and after placement. This may be accomplished through one of the following methods:

- a. Couplers which “splice” innerduct sections together are available from most innerduct manufacturers. Do not use couplers which reduce the inside diameter of the innerduct.
- b. Split duct may be applied to the cable during racking
- c. A section of innerduct which has an inside diameter greater than the outside diameter of the installed innerduct may be used in a sleeve operation. This section of innerduct must be slid over the innerduct coming from the entrance duct BEFORE the pull-line is installed. The section of larger innerduct must be long enough to reach from the entrance duct to the exit duct while passing around the periphery of the manhole where it will be racked, plus an additional 9 ft (3 m) on each end which will be inside the duct bank after racking.

**3.9.** After placement, all innerduct must be capped or plugged to prevent moisture or foreign matter from entering until the cable installation starts.

### Pull-Line

**3.10.** Various types of pull-line have been used successfully with fiber optic cable. Pull-lines can be of either a round or flat cross section. Selection of a pull-line will depend upon the length and conditions of the pull. Small diameter pull-line may have a tendency to cut innerduct when under tension.

**3.11.** Available pull-line materials include wire rope, polypropylene, and aramid yarn. For pulls using winches, materials with low elasticity such as wire rope and aramid yarn can minimize surge-induced fluctuation in pull-line tension. Consult your company’s standard practices with regards to pull-line materials.

**3.12.** Some innerduct is available with preinstalled pull tape or line. Otherwise, pull-line can be installed by rodding or blowing. Lubrication of the pull-line may be necessary for ease of installation or to prevent the line from cutting the innerduct.

### Pulling Grips

**3.13.** Corning Cable Systems recommends the use of a factory or field-installed wire mesh pulling grip and swivel during cable pulls. Pulling grips provide effective coupling of pulling loads to the jacket, aramid yarn, and central member of fiber optic cables.



**3.14.** For instructions on field installation, refer to SRP 004-137, Installing a Wire Mesh Pulling Grip.

**3.15.** The use of a swivel between the pull-line and pulling grip is required to prevent the pull-line from imparting a twist to the cable. A swivel that contains ball-bearings is recommended to prevent binding at high tensions.

### Lubricants

**3.16.** Cable lubricant is recommended for most fiber optic cable pulls as a means of lowering pulling tension. Short hand-pulls may not require lubricant. Considerations in choosing a lubricant are material compatibility, drying time, temperature performance, and handling characteristics.

**3.17.** As noted in the cable precautions, cable lubricants must be compatible with the fiber optic cable’s outer sheath. Refer to the lubricant manufacturer’s specifications. Use of incompatible liquids, such as liquid detergent, for a lubricant can cause long term sheath damage.

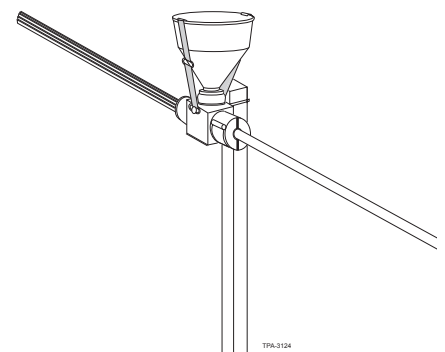

**3.18.** Lubricant should be applied according to the manufacturer's recommendations. Some lubricant vendors recommend an applicator to coat the cable as it enters the innerduct, others suggest distributing lubricant throughout the innerduct by pulling a swab through the innerduct as part of the pull-line placement. Pumps or gravity feed devices can also be used to inject lubricant into the innerduct.

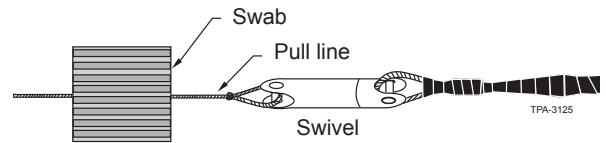

**3.19.** Additional lubricant should be added before bends and known severe offsets and sections with "uphill" elevation changes.

### Tension-Monitoring Equipment

**3.20.** Fiber optic cable is subject to damage if the cable's specified maximum tensile force is exceeded. Except for short runs or hand-pulls, tension must be monitored. Refer to cable specification sheets for maximum tension. Exceeding the specified maximum tension will void the warranty of the cable product.

**3.21.** The use of a winch with a calibrated maximum tension is an acceptable procedure. The control device on such winches can be hydraulic or in the form of a slip clutch. Such winches should be calibrated frequently.

**3.22.** The use of a breakaway link (swivel) can be used to ensure that the maximum tension of the cable is not exceeded. Breakaway links react to tension at the pulling eye and should be used as a fail-safe rather than a primary means of monitoring tension.

**3.23.** A dynamometer or in-line tensiometer may also be used to monitor tension in the pull-line near the winch. This device must be visible to the winch operator or used to control the winch. Special winches are available that monitor the tension remotely at the pulling eye via a wire in the pull-line. Such winches may also provide a record of the tension during pulls.

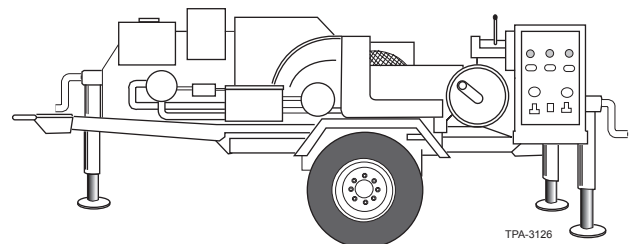

**NOTE:** Carefully select equipment that maintains bend radius. Not all outside plant equipment is well-suited for fiber optic cable installation.

### Pulling Equipment

**3.24.** All pulling equipment and hardware which will contact the cable during installation must maintain the cable's minimum bend radius. Such equipment includes sheaves, capstans, bending shoes, and quadrant blocks designed for use with fiber optic cable.

**3.25.** Situations that require use of a radius-maintaining device are encountered at feed and pull manholes, at bends, and where entrance and exit ducts in a manhole are offset.

## 4. INSTALLATION TECHNIQUES

**4.1.** Various techniques are available to ease the installation of long lengths of fiber optic cable. All have been used extensively in the field.

**4.2.** The length of cable that can be pulled in one operation will vary with duct conditions, the equipment used, pulling technique selected, and the skill of the craftsmen. Normally, a short pull [less than 3000 ft (913 m)] with two or fewer 90-degree bends may be pulled without an intermediate-assist winch or hand assistance.

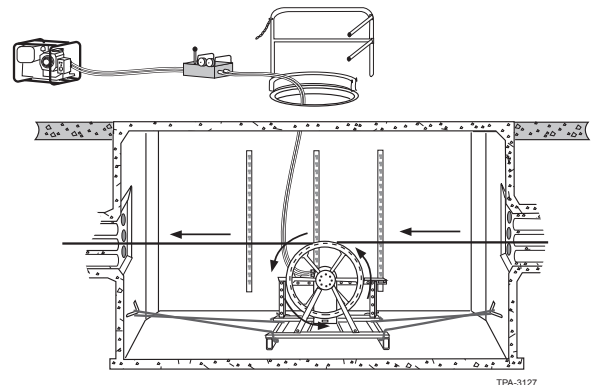

**4.3.** Use of multiple winches requires compatible pulling equipment and careful coordination of winch speeds. Consult the equipment manufacturer's instructions for necessary details.

### Center-Pulls and Backfeeding

**4.4.** Longer cable pulls, or those involving many bends, may also use center-pull and "backfeeding" techniques.

**4.5.** In a center-pull operation, set up the cable reel near the center of the duct run to be pulled. Pull the cable in one direction to the next designated splice point.

**4.6.** Unreel the remaining cable in a figure-eight configuration.

**4.7.** Flip over the figure-eight so that the pulling-eye end of the cable is on top. This can be easily accomplished by three installers, one at each end of the eight, and one at the center.

**4.8.** Pull the exposed end of the cable in the opposite direction to complete the pull. Hand tending of the cable paying off from the figure-eight is normally required.

### Backfeeding

**4.9.** "Backfeeding" may be used to provide a series of shorter, lower-tension pulls in one direction. When backfeeding, pull enough cable out of the manhole to reach the intended end point of the pull, plus racking and splicing slack. This cable should be figure-eighted as it emerges from the manhole.

**4.10.** Flip over the figure-eight so that the pulling-eye end of the cable is on top. This can be easily accomplished by three installers, one at each end of the eight, and one at the center.

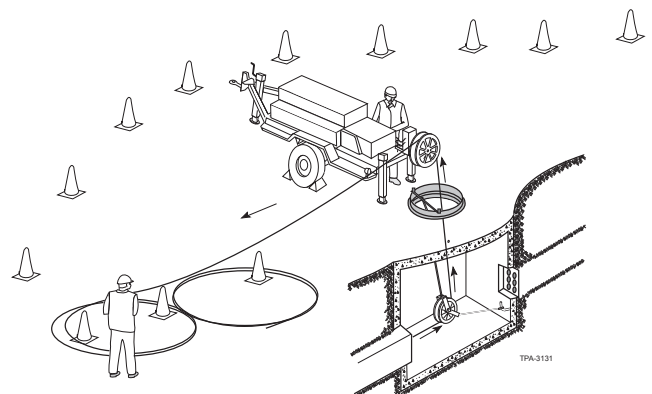
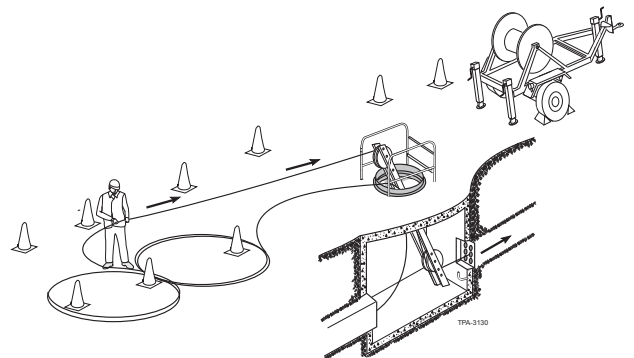
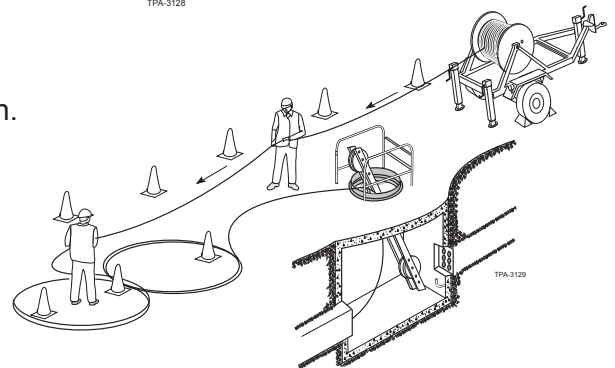
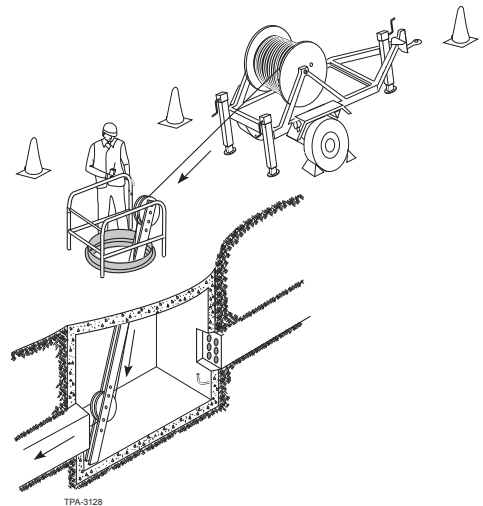

**4.11.** After the pulling eye is connected to the next section of the pull-line, feed the cable by hand back into the manhole and pull it to its next destination. The cable may be pulled directly from a figure-eight by a winch, provided the capstan or sheave used at the entry manhole ensures sufficient bend radius. Hand tending of cable paying off from figure-eights is normally required.

	<p><b>WARNING:</b> Before pulling cable directly from a figure-eight, make sure that the area inside the loops of the cable is clear of personnel and equipment. Failure to do so may result in injury to personnel or damage to the cable.</p>
--	---

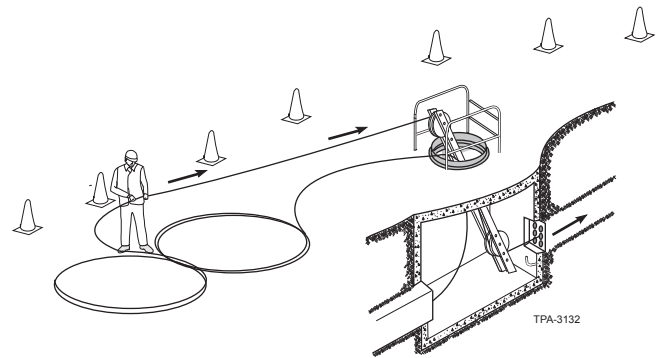

## 5. INSTALLATION PROCEDURE

**5.1.** This section will provide an overview of an installation operation. As noted earlier, your company's practices and local conditions may take precedence over these guidelines.

**5.2.** Prepare the manholes in the duct section where the cable is to be placed:

- a. Place barricades
- b. Monitor gas
- c. Establish ventilation
- d. Pump water
- e. Inspect ladders, racks, and duct banks

**5.3.** If not already in place, install the innerduct and pull-line. Tie down exposed innerduct in manholes to prevent dragging of innerduct during pulling operations.

Relocate existing utilities if necessary.

**5.4.** Set up winches, monitoring devices, lubrication points, bend radius devices (sheaves, capstans, bending shoes, etc.), and means of communications along the route prescribed in the pull plan.

**5.5.** Locate the cable reels at the appropriate points of the route.

**5.6.** Remove reel lagging and retrieve the cable data sheets (if present) from each reel for your company's as-built records.

**5.7.** Inspect the reels and equipment on which they are mounted for any bolts, nails or other protrusions that could damage the cable as it is paid off.

**5.8.** Ensure that the reel trailer or jack stands are stable, and that the reel may turn freely without binding. The reel must be level to allow proper pay off of cable.

**NOTE:** Jack stands can be unstable if not set up properly. Consult your company's practices if jack stands are going to be used in your installation.

**5.9.** Align the reel at the feed hole so that the cable can be routed from the top of the reel into the duct bank in as straight a path as possible.

**5.10.** If not previously installed, attach the pulling grip to the cable, and attach the grip to a swivel. The swivel should be securely fastened to the pull-line. See the pull-line manufacturer's recommendations for appropriate knots.

- 
- 5.11.** A warning marker (colored tape or similar material) may be attached to the pull-line several feet in front of the pulling grip to alert observers at manholes that the cable is approaching.
- 5.12.** Apply cable lubricant as required.
- 5.13.** Verify that communication lines are functional and crews are in place at feed, pull, and intermediate manholes.
- 5.14.** Start the pull at a slow speed, passing the pull-line and cable over and around the capstans, sheaves, and other devices required to maintain the minimum bend radius. Begin tension monitoring with a calibrated device as soon as tension is applied to the cable. If necessary, aid the cable feed by turning the reel by hand. Ensure that the cable is fed only as fast as the pull-line is moving. Back tension on the reel will prevent too much cable being fed off.
- 5.15.** Once the cable has moved a minimum of 5 ft (1.3 m) into the innerduct, accelerate the pull smoothly to its intended speed [50-100 ft (15.2-30.4 m) per minute is desirable].
- 5.16.** Continue the pull at a steady rate. If it is necessary to stop the pull at any point, the winch operator should stop the pull, but NOT release the tension unless instructed to do so. Pulls can be easily resumed if tension is maintained on the pull-line and cable.
- 5.17.** The cable should be visually observed during the following situations:
- When it passes through any intermediate manhole in which innerduct continuity is broken.
  - Where use of a radius-maintaining device is required due to a bend or offset of entrance and exit ducts.
  - At intermediate-assist winches.
- 5.18.** Ensure that the bend radius is maintained, and that the cable is properly routed through the sheaves, capstans, bending shoes, etc.. Stop the pull if the cable is misrouted, and correct the problem before resuming. If the innerduct is being pulled along with the cable, stop the pull and secure the innerduct with temporary cable ties.
- 5.19.** When the cable end reaches a backfeed point or splice point manhole, pull the cable out of the hole using a setup similar to that at the feed hole to maintain bend radius.
- After passing around the winch, the cable slack should be figure-eighted in an area where it will not be subject to damage by personnel or traffic. Follow the procedure in Step 4.9 for flipping the figure-eight so that the pulling grip end of the cable will be on top before the pull is resumed.
- NOTE:** Pulls which have a large number of intermediate manholes will require a large quantity of cable slack. This slack must be pulled from the two end points and backfed to provide racking slack.

**5.20.** At splice points, pull sufficient slack (typically 40 ft [10 m] of slack from the lip of the manhole) to reach the intended splicing location, plus enough slack to permit closure preparation and splicing.

**5.21.** Verify and record the distance markings printed on the cable for as-built documentation.

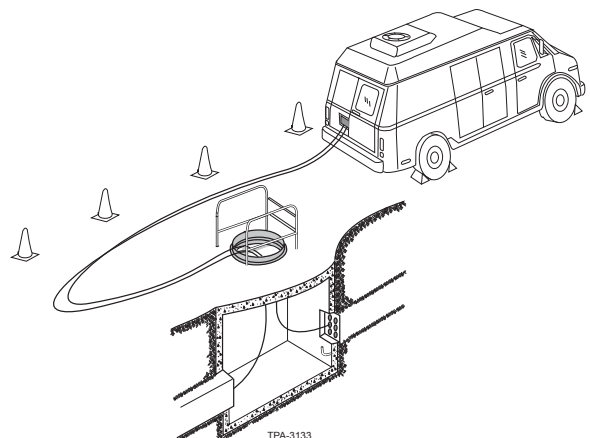



**5.22.** Once the cable is pulled into place and appropriate slack is available at splice or termination points, begin securing all the innerduct to cable racks on the manhole walls. Begin racking at the center manhole and proceed to the end manholes. Maintain the cable's specific minimum bend radius.

**5.23.** At points where the innerduct is continuous through the manhole, push the innerduct and cable to the rack and secure with appropriate cable ties. Maintain the cable's minimum bend radius.

**5.24.** If the innerduct is not continuous, rack the split duct, or the larger outside diameter section of innerduct before the pull.

**5.25.** Store coiled splicing slack in the splicing manholes so that it is not likely to be damaged during later work in the manhole. If possible, store the slack in an enclosure designed to store splicing slack and a splice closure. Place an end cap on any bare cable ends to prevent moisture or dirt intrusion.

**5.26.** Fiber optic warning signs should be placed on all innerduct containing fiber optic cable. Warning signs can help prevent damage resulting from the cable being mistaken for something else.

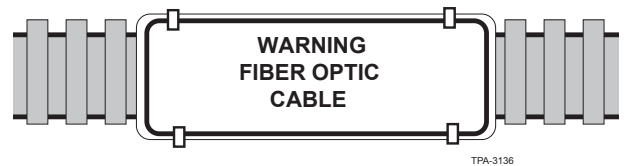
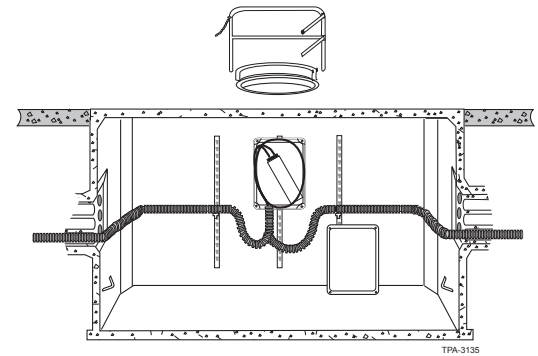
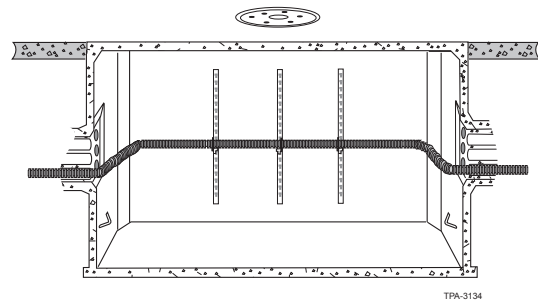

Corning Cable Systems LLC • PO Box 489 • Hickory, NC 28603-0489 USA  
1-800-743-2671 • FAX +1-828-325-5060 • International +1-828-901-5000 • <http://www.corning.com/cablesystems>

Corning Cable Systems reserves the right to improve, enhance, and modify the features and specifications of Corning Cable Systems' products without prior notification. Altos is a registered trademark of Corning Cable Systems Brands, Inc. SST-Ribbon and SST-UltraRibbon and trademarks of Corning Cable Systems Brands, Inc. All trademarks are the properties of their respective owners. Corning Cable Systems is ISO 9001 certified.

© 1988, 1998, 2001, 2008, 2010 Corning Cable Systems. All rights reserved. Published in the USA.