



- Visit <http://www.corning.com/cablesystems/videos> for additional information and videos
- Visit www.corning.com/cablesystems/safety for full safety precautions

CAUTION: Recommend the use of safety glasses (spectacles) conforming to ANSI Z87, for eye protection from accidental injury when handling chemicals, cables, or working with fiber. Pieces of glass fiber are very sharp and have the potential to damage the eye.

WARNING: DO NOT use magnifiers in the presence of laser radiation. Diffused laser light can cause eye damage if focused with optical instruments. Should accidental eye exposure to laser light be suspected, arrange for an eye examination immediately.

WARNING: Never look directly into the end of a fiber that may be carrying laser light. Laser light can be invisible and can damage your eyes. Viewing it directly does not cause pain. The iris of the eye will not close involuntarily as when viewing a bright light. Consequently, serious damage to the retina of the eye is possible. Should accidental eye exposure to laser light be suspected, arrange for an eye examination immediately.

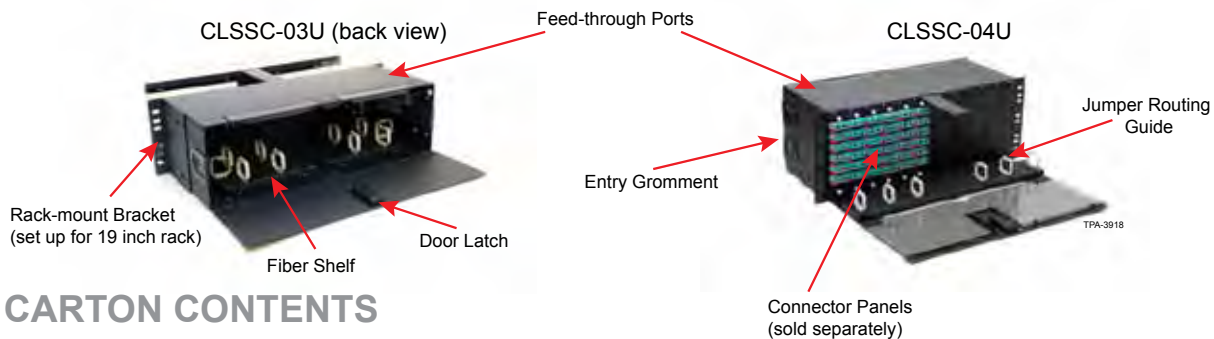

1. CARTON CONTENTS

- Closet Connector Housing
- Hardware Kit containing:
 - (1) Unit identification label
 - (1) Label, 12 x 12 position
 - (3 feet) Spiral wrap
 - (12) Cable ties
 - (1) Universal Cable Clamp (UCC) kit
 - (1) Strain-relief bracket
 - (1) 8-32 x 0.5 in Phillips-head screw
 - (4) 12-24 x 0.5 in Phillips-head screws
 - (2) 6-32 Wing nuts
 - (1) M6 washer
 - (2) U-shaped washers

2. TOOLS REQUIRED

- Phillips-head screwdriver
- 3/8 inch socket or wrench
- 5/16 inch socket or wrench
- Sand paper

3. ADDITIONAL MATERIALS (PURCHASED SEPARATELY)

May or may not be required depending on your application.

- Connector Panels (CCH-CPXX-YY)
- Grounding kit (HDWR-GRND-KIT) for armored cable
- Additional UCC kits (UCC-001/-005)
- Buffer Tube Fan-Out kit (FAN-XX36-YY)
- Closet Splice Housing (CSH-05U-F)
- Pigtailed Panels (CCH-CPXX-YY-P03ZZ)
- Pigtailed Modules (CCH-RMXX-YY-P03ZZ)
- 23- or 24-in rack-mounting brackets

4. MOUNT THE HOUSING TO THE RACK

IMPORTANT: If installing in a 23- or 24-in rack, brackets must be ordered separately and installed prior to mounting the housing to the rack.

- Step 1:** Position the housing in the desired location in the rack.
- Step 2:** Use two 12-24 x 0.5 Phillips-head screws (or hardware provided by rack manufacturer) per side. Recommend two people to install this, one to hold it and one to insert the screws.

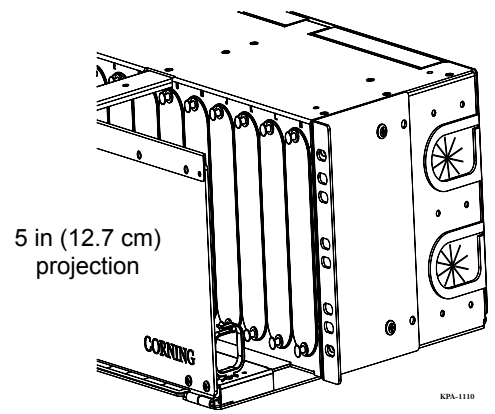

5. HOUSING PREPARATION

- Remove the Front or Rear Doors (to facilitate cable and connector panel install)

- Step 1:** Open the door by pressing down on the door latch.
- Step 2:** Slide the door to the left.
- Step 3:** Slightly bow the door to release the hinges.

- Remove Feed-through Ports (if routing pigtails to a Closet Splice Housing)

Use Phillips-head screwdriver to remove two screws per port.

6. CABLE PREPARATION

IMPORTANT: Pierce entry grommet and slide down cable before accessing.

- Indoor Cables: Access 79 in (2 m)

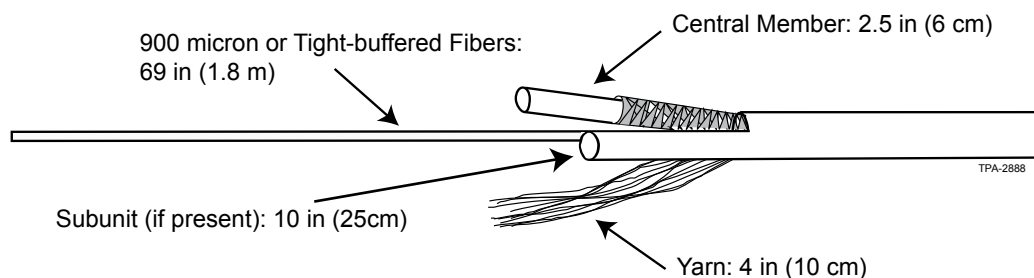

- Outdoor Cables with 36-inch Fan-Out Kit: Access 56 in (1.4 m)

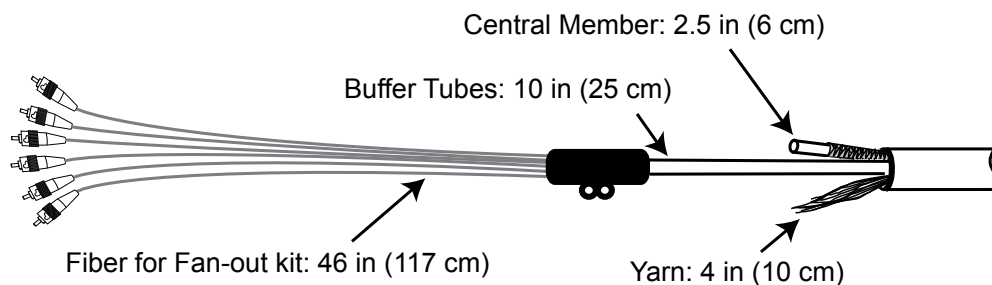

7. CABLE STRAIN-RELIEF

IMPORTANT: If you are installing outside plant cable or temperature fluctuates widely along any part of the cable, the strength members of the cable must be strain-relieved. Failure to do so may result in damage to the cable as temperature varies. Other situations only require the cable to be strain-relieved by sheath retention only.

- **Sheath retention strain-relief using the UCC**

- Step 1:** Cut strength member(s) flush with outer jacket (see note).
- Step 2:** Follow instructions provided with UCC kit to secure cable.
- Step 3:** Attach UCC clamshell to the strain-relief bracket.
- Step 4:** Determine location of cable entry and attach strain-relief bracket using two 6-32 wing nuts.

NOTE: If using cable with 900 micron fibers and no subunit jacketing, use about a foot of spiral wrap to completely cover the fibers until they are well inside the housing. Make sure the spiral wrap extends up over the cable jacket.

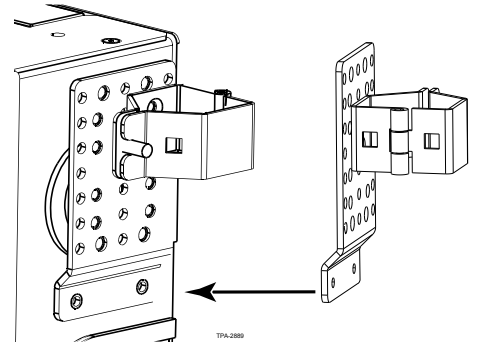

- **Sheath retention strain-relief using Cable Ties**

- Step 1:** Cut strength member(s) flush with outer jacket (see note).
- Step 2:** Use two cable ties to secure cable strain-relief bracket.
- Step 3:** Attach strain-relief bracket to the housing using two 6-32 wing nuts.

NOTE: You may also use this method inside the housing by attaching the cable to the feed-through port holes with two cable ties.

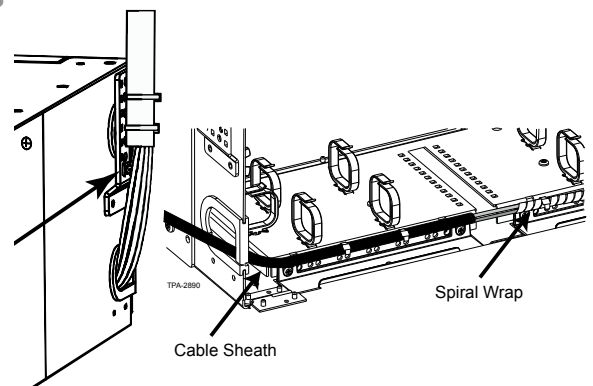

- **Strength member strain-relief**

- Step 1:** Install the U-shaped washer and the flat washer to the strain-relief bracket in the order shown using the 8-32 x 0.5 Phillips-head screw.
- Step 2:** Place the central member and yarn, if present, between the U-shaped and flat washers.
- Step 3:** Wrap yarn around the screw in a clockwise direction under the U-shaped washer.
- Step 4:** Tighten the screw and trim off the excess yarn.

- **Grounding armored cable**

Use one HDWR-GRND-KIT per armored cable. Follow instructions provided with kit to properly ground the cable.

- Step 1:** Remove the paint from the rack with sand paper to ensure metal-to-metal contact at the grounding location.

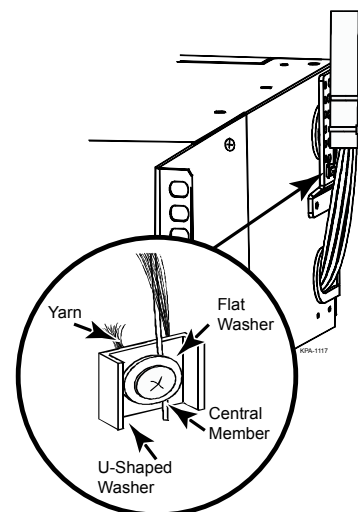

Step 2: Attach the other end of the ground wire from the cable to the rack. The rack must be grounded to the primary building ground for this to work properly.

OR

Step 2: Attach the other end of the ground wire from the cable to a rack-mount grounding bus.

8. CABLE ROUTING



CAUTION: Fiber optic cable is sensitive to excessive pulling, bending, and crushing forces. Consult the cable specification sheet for the cable you are installing. Do not bend the cable more sharply than the minimum recommended bend radius. Do not apply more pulling force to the cable than specified. Do not crush the cable or allow it to kink. Doing so may cause damage that can alter the transmission characteristics of the cable; the cable may have to be replaced.

• Installing Indoor Cable with Factory or Field-Installed Connectors

Route fiber slack through routing clips after installing connectors if needed..

IMPORTANT: Ensure there is enough slack to allow the panel to be removed from the front.

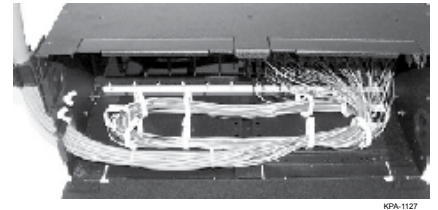

• Installing Cable with a Buffer Tube Fan-Out (BTF) Kit

Step 1: Install BTF onto cable.

Step 2: Slide the fan-out body into the cut-out in the fiber shelf.

Step 3: Secure the fan-out body to the fiber shelf with a cable tie.

Step 4: Route fiber slack through the routing clips.

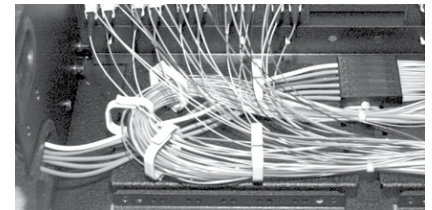

• Installing Pigtailed Panels/Modules

Step 1: Mark ends of pigtails to identify which panel they are coming from.

Step 2: If installing a pigtailed module, remove the fiber shelf with a Phillips-head screwdriver.

Step 3: Feed pigtail through appropriate feed-through slot and into a splice housing (CSH-05U-F) mounted above or below.

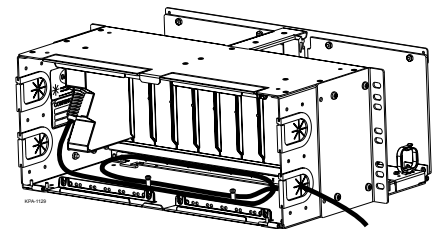

9. COMPLETE INSTALLATION

Step 1: Reinstall any doors that were removed earlier.

Step 2: Close both front and rear doors.

Step 3: Record fiber identification on the 12 x 12 position label in a logical way and attach to the slide-out label plate.

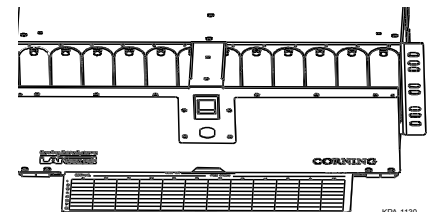

Corning Cable Systems LLC • PO Box 489 • Hickory, NC 28603-0489 USA
1-800-743-2671 • FAX +1-828-325-5060 • International +1-828-901-5000 • <http://www.corning.com/cablesystems>

Corning Cable Systems reserves the right to improve, enhance, and modify the features and specifications of Corning Cable Systems' products without prior notification. LANscape is a registered trademark of Corning Cable Systems Brands, Inc. All trademarks are the properties of their respective owners. Corning Cable Systems is ISO 9001 certified.
© 2011 Corning Cable Systems. All rights reserved. Published in the USA.