

- Refer to Installation Guides 003-427 and 003-428 for complete instructions.
- Visit <http://www.corning.com/cablesystems/videos> for additional information and videos.
- Visit [www.corning.com/cablesystems/safety](http://www.corning.com/cablesystems/safety) for full safety precautions.

### Carton Contents

- (2) Dust covers

### Tools Required

- 5/16-inch socket or nut driver

- (2) 6-32 self-locking nuts

### Specifications

|             | WCH-04P      | WCH-06P        | WCH-12P                   |
|-------------|--------------|----------------|---------------------------|
| Part Number | WCH-DUST-CVR | WCH-DUST-CVR-D | WCH-DUST-CVR-D (2 needed) |

### Installation

- Step 1:** Loosen the 6-32 self-locking nut holding the top right strain-relief bracket using a 5/16-inch nut driver but do not remove.
- Step 2:** Remove the vinyl cap from the pem stud.
- Step 3:** Place dust cover with TWO holes over the top right jumper port (and/or the bottom left jumper port for WCH-12P). Ensure that dust cover is over the pem studs and between the jumper strain-relief bracket and the housing.
- Step 4:** Place dust cover with ONE hole on the bottom right jumper port (and/or the top left jumper port for the WCH-12P).
- Step 5:** Adjust the dust cover to fit flush with the housing and secure with a 6-32 self-locking nut. Retighten the previously loosened nut where applicable.

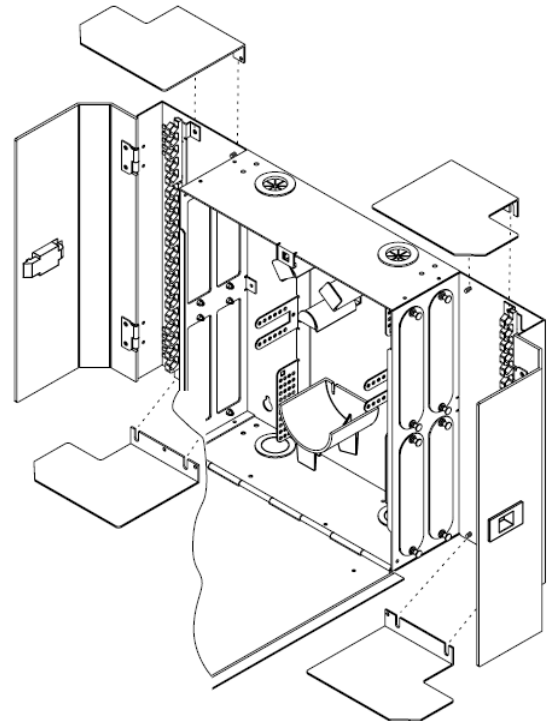

Corning Cable Systems LLC • PO Box 489 • Hickory, NC 28603-0489 USA  
1-800-743-2671 • FAX +1-828-325-5060 • International +1-828-901-5000 • <http://www.corning.com/cablesystems>

Corning Cable Systems reserves the right to improve, enhance, and modify the features and specifications of Corning Cable Systems' products without prior notification. All trademarks are the properties of their respective owners. Corning Cable Systems is ISO 9001 certified.

© 1996, 1998, 200, 2010 Corning Cable Systems. All rights reserved. Published in the USA.