

These commodities/technical data are controlled for export by the U.S. State Department. They may not be transferred, transshipped on a non-continuous voyage, or otherwise be disposed of outside of the United States, either in their original form or after being incorporated into other end-items, without the prior written approval of the U.S. Department of State.

REVISIONS				
LTR	DESCRIPTION	ECN	DATE	APPROVED
C	UPDATED SPECIFICATIONS	7008	9/25/07	JDW
D	UPDATE PHASES – SEC 2.1.5	8272	9/18/09	MPD
E	UPDATE TO 1449 THIRD ED.	8893	7/13/10	JDW



**STEEL
ENCLOSURE**



**FIBERGLASS COMPOSITE
ENCLOSURE**

DRAWN	MLH	DATE	3/12/06	 Transtector Systems, Inc. 10701 Airport Road, Hayden, ID 83835 800.882.9110 208.772.8515 www.transtector.com
CHECKED	RRR	DATE	3/23/06	
ENGRG APPD	JDW	DATE	3/23/06	
PROJ APPD	JN	DATE	3/24/06	
APPROVED				
NOTICE: THE INFORMATION AND DESIGN IN THIS DOCUMENT IS THE PROPERTY OF TRANSECTOR SYSTEMS. ALL RIGHTS RESERVED.				TITLE Specification APEX I max 120V AC Surge Protector
DOCUMENT NUMBER		1400-581		REV E
CAGE		30992		PAGE 1 of 7

TABLE OF CONTENTS

- 1.0 GENERAL MODEL DESCRIPTION3
- 2.0 SPECIFICATION/PERFORMANCE3
 - 2.1. Continuous Operating Electrical Specifications:3
 - 2.2. Non-Metallic Enclosure Mechanical Specifications:3
 - 2.3. Metallic Enclosure Mechanical Specifications:4
 - 2.4. Surge Specifications:4
 - 2.5. Electrical Connections/Installation Requirements:4
- 3.0 INSTALLATION INSTRUCTIONS5
 - 3.1. Disconnect Means:5
 - 3.2. Remote Annunciation Program Settings:6
- 4.0 ENVIRONMENTAL6
- APPENDIX A: SYSTEM WIRING DIAGRAM7

1.0 GENERAL MODEL DESCRIPTION

Apex Imax Series AC Power Surge Protector

The APEX Imax Series of surge protection devices is a UI type 2 SPD designed to protect a wide range of 120VAC power configurations. The standard surge protector enclosure is a fiberglass composite, UL Type 4, with metal enclosure options depending on user requirements. The design is based around a modular approach using robust surge assemblies that each bolt directly across AC bus bars. Each surge element connects to the monitoring board through a card edge connector system and its functional health can be discriminated through the visual and relay alarm connection point features. All visual indication is shown through the front panel window, and the annunciation contacts are located conveniently on the interior main board assembly and multiplexed for easy failure demonstration. The surge elements are constructed inside 94V0 flame rated plastic housings. The APEX Imax utilizes an extraordinarily robust combination of silicon avalanche suppressor diode (SASD) and metal oxide varistor (MOV) technologies to achieve a balance of very low voltage protection levels at high induced surge currents, with effective abnormal over-voltage fault current fail safe mode. The surge elements are constructed using Transtector's ASAT™ patented assembly construction to achieve this premier performance. The surge protector is constructed in such a manner as to effectively couple the surge performance of high endurance SASD and MOV elements along with safe, built in disconnect elements. The Apex Imax Series are listed to UL 1449 and are Motorola R56 compliant.

2.0 SPECIFICATION/PERFORMANCE

2.1. Continuous Operating Electrical Specifications:

- 2.1.1. Nominal Operating Voltage: 120V, 120/240V, 120/208V
- 2.1.2. Amperage Rated at Maximum: up to 2000A Service
- 2.1.3. Frequency Range: 50 to 400Hz
- 2.1.4. Fault Current Rating: up to 65kAIC
- 2.1.5. Phases Single and 3-Wye
- 2.1.6. Modes L-L and L-N
- 2.1.7. Maximum Continuous Operating Voltage (MCOV)
 - 2.1.7.1. 138VAC L-N
 - 2.1.7.2. 276VAC L-L
- 2.1.8. Relay Contact Ratings 250VAC, 6A

2.2. Non-Metallic Enclosure Mechanical Specifications:

- 2.2.1. Enclosure Type UL Type 4, Screw Access
- 2.2.2. Enclosure Material Fiberglass Composite
- 2.2.3. Enclosure Dimensions 12"x10"x6" (30.5cmx24.5cmx15.3cm)

2.2.4. Weight, 3 Phase, Fully Configured 14lb (6.5kg)

2.3. Metallic Enclosure Mechanical Specifications:

2.3.1. Enclosure Type..... UL Type 4, Screw Access

2.3.2. Enclosure Material.....Steel, Grey Powder Coat

2.3.3. Enclosure Dimensions..... 12"x10"x8" (30.5cmx24.5cmx20.3cm)

2.3.4. Weight, Fully Configured 24lb (10.9kg)

2.4. Surge Specifications:

2.4.1. UL Voltage Protection Rating (VPR), Type 2 SPD

2.4.1.1. 900V (peak) L-L

2.4.1.2. 1200V (peak) L-N

2.4.2. Testing Per ANSI/IEEE C62.45 2002,IEEE C62.41 2002 Wave Shapes Location Category C High and C Low.

2.4.3. Lightning Test per IEC 61643-1, Class II.....>4kV max @ 160kA

2.4.4. Long Wave 10/1000 Stress Surge Per IEEE C62.41 2002..... < 700V @ 1.5kA

2.4.5. Primary Suppressor (Max. Design Limit): SASD 20kA

2.4.6. Secondary Suppressor (Max. Design Limit): MOV 200kA

2.4.7. Combined Primary Secondary 160kA

2.4.8. Response Time (Max.) : 1ns

2.4.9. Standby Power (Max.) : 1W

2.4.10. UL "In" 20kA

2.5. Electrical Connections/Installation Requirements:

2.5.1. AC Power Input Wire Size:.....#4AWG-1/0 (9.3mm max)

2.5.2. Wire connections.....Phase/Neutral Plus Safety Ground

2.5.3. Isolated Relay Terminals.....3-Pin connector, #22 – 14 AWG (2mm max)

2.5.4. Fault Current Rating...NEC 285.6 Upto 65k Amps Asymmetrical Interrupt Current

3.0 INSTALLATION INSTRUCTIONS

3.1. Disconnect Means:

It is recommended that the suppressor be installed off a dedicated disconnect, molded case switch or circuit breaker with a minimum 60 Amp rating. This provides a safe means for electrical system power up or disconnect. The disconnect means should be sized for use with the appropriate gauge wire for the application and fault current rating of the power distribution system components.

Refer to Figure 1 for mechanical mounting requirements for wall space and adequate door clearance.

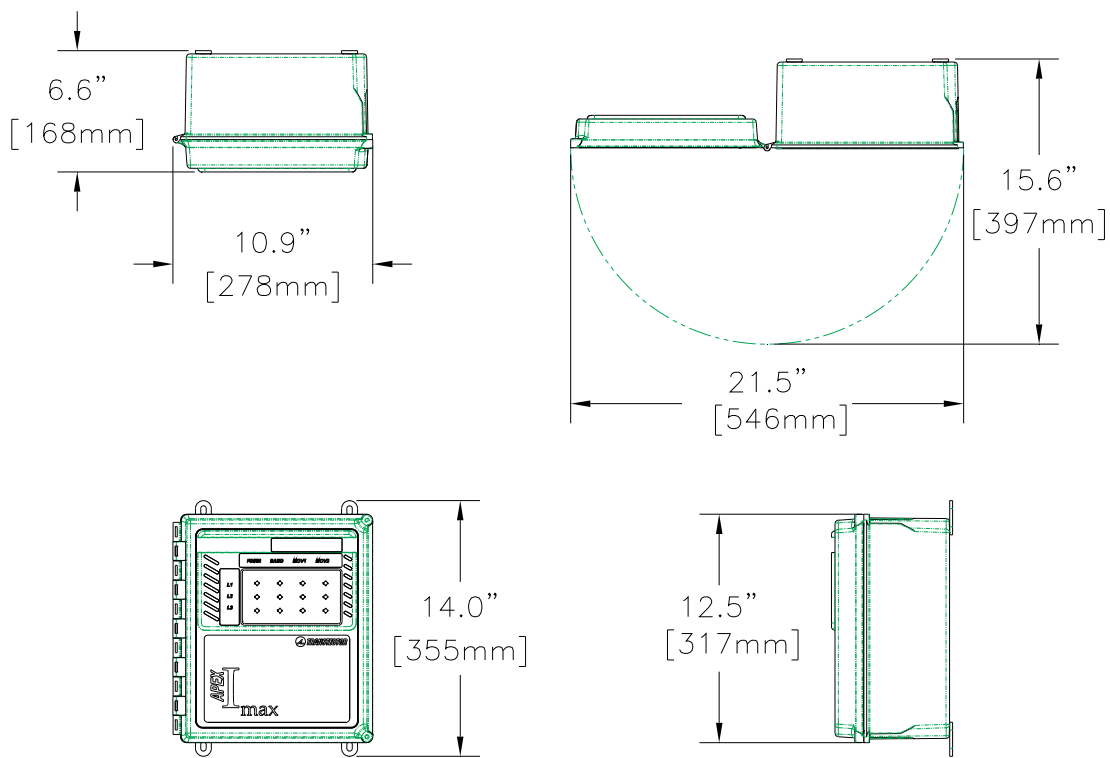
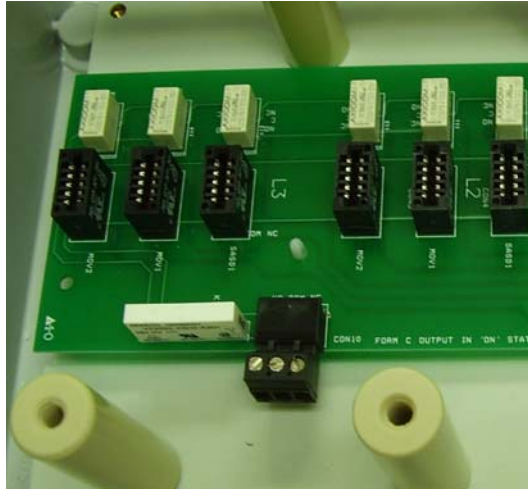

Figure 1

3.2. Remote Annunciation Program Settings:

The form C isolated relay contacts are factory configured series/parallel with all modules interconnected to a single connector for ease of monitoring the status of the entire Imax suppressor. Figure 2 shows connector location. Relay contact positions are identified in a power applied state with the three terminal positions NO-C-NC as illustrated.



Connector Positions NO-C-NC as indicated on PCB
Figure 2 – Bus bar Removed for Clarity

A typical application circuit is shown in Figure 3, where a power source can be used to turn off a lamp in the event of suppressor failure.

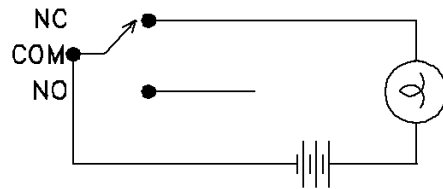

LAMP CIRCUIT WITH POWER SOURCE
LAMP TURNS OFF UPON TVSS FAIL

Figure 3

4.0 ENVIRONMENTAL

- 4.1. Operating Temperature:..... -40C to +75C
- 4.2. Storage Temperature: -40C to +75C
- 4.3. Relative Humidity: 100% non-condensing
- 4.4. Ventilation: not required, direct sun loading is not recommended

APPENDIX A: SYSTEM WIRING DIAGRAMS

