

THIS DRAWING HAS BEEN GENERATED AND IS MAINTAINED BY A CAD SYSTEM. CHANGES SHALL ONLY BE INCORPORATED AS DIRECTED BY THE DESIGN ACTIVITY.

REVISIONS				
LTR	DESCRIPTION	ECO NUM.	DATE	APPROVED
B	UPDATE PERFORMANCE NUMBERS, ADD MODELS		6/3/04	JDW

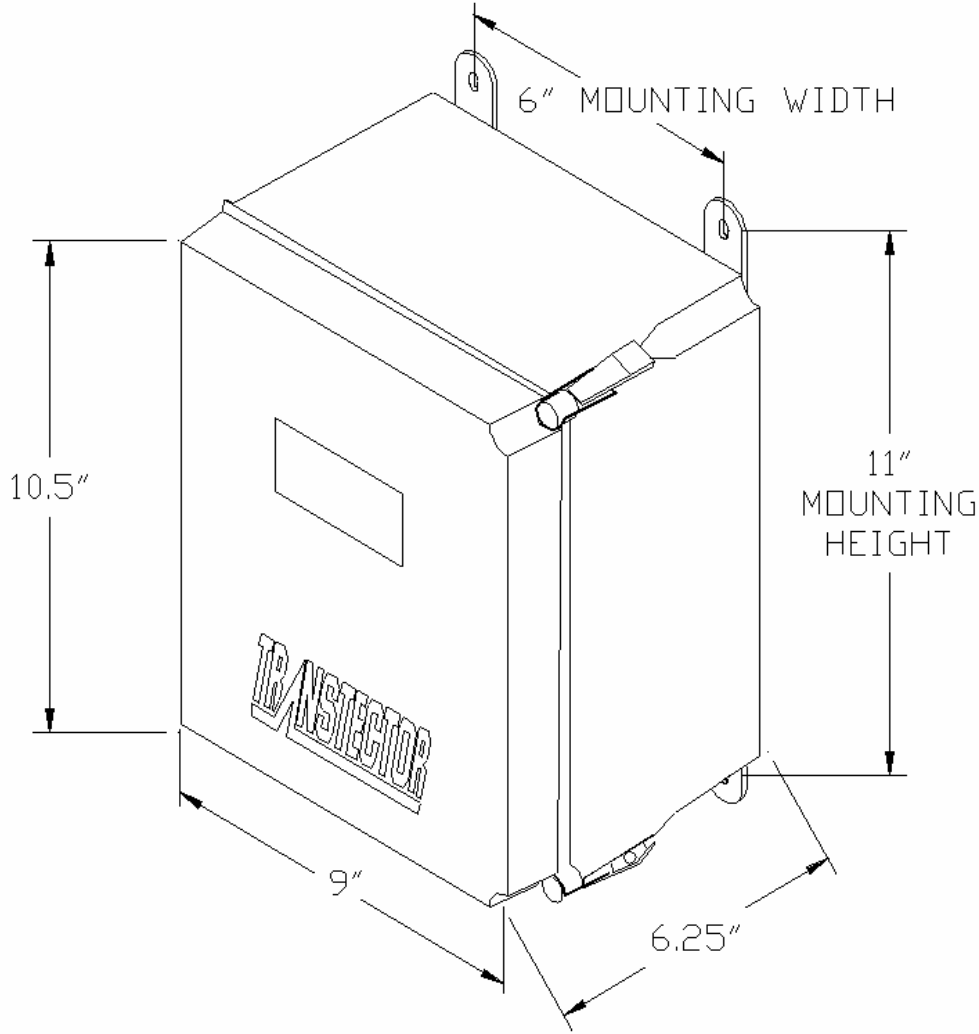

UNLESS OTHERWISE SPECIFIED DIM. IN INCHES BEFORE PLATING

DRAWN: <b>MLH</b>	DATE 04/30/04
CHECKED: JDW	5/16/02
ENGR. APPD: <b>CDD</b>	5/16/02
PROJ. APPD: <b>MLH</b>	5/17/02
APPROVED:	



**Transtector Systems, Inc.**  
 10701 Airport Road, Hayden, ID 83835  
 800.882.9110 208.772.8515 www.transtector.com

TITLE: **SPECIFICATION  
 MCP-OD SERIES PROTECTORS**

MATERIAL:  
**NOTED**

**NOTICE:** THE INFORMATION AND DESIGN CONTAINED HEREIN IS THE PROPERTY OF TRANSECTOR SYSTEMS. WHO RESERVES ALL RIGHTS THERETO

SIZE <b>A</b>	CAGE <b>30992</b>	DRAWING NUMBER <b>1400-447</b>	REV <b>B</b>
SCALE = N/A		PAGE 1 OF 3	

## A.C. VOLTAGE SURGE SUPPRESSOR Model: MCP-OD SERIES

**1.0 GENERAL DESCRIPTION:** The MCP-OD Series A.C. Voltage Surge Suppressors are fast responding, high current handling, solid-state devices designed to protect electronic equipment and systems from transient over voltages on 120/240 VAC, single phase, 3-wire services and 120/208 VAC three phase, 4-wire services. These suppressors are designed for the highest system exposure per category C2 and IEEE C62.41 1991 for the MCP 120TA-5M-OD and category C3 for the MCP 120TA-10M-OD and MCP 120W-10k-OD. The MCP 120W SASD/MOV surge suppressor features the most advanced SASD and MOV combination designed to exceed IEEE standard surge test waveforms and levels with 320kA of MOV device ampacity. The suppressor performs this function by limiting the magnitude of transient over voltages that are present upon the A.C. power lines. Continuous bipolar, bi-directional, non-interrupting protection is provided. The MCP 120-OD Series products automatically reset after each suppression function with no degradation of protection capabilities. These suppressors utilizes silicon junction avalanche suppressor diodes (SASD) in a Lattice Matrix configuration as its primary suppression technology with a 300 and 500 Joule energy rating, respectively. A secondary suppressor is provided on the MCP 120TA-5M-OD and MCP 120TA-10M-OD units that consists of metal oxide varistors (MOV) with a 5000 Joule energy rating. The MCP 120-OD devices begin to suppress transient over voltages at approximately 120% of the peak nominal voltage of the A.C. sine wave (para. 2.2.1.1). At maximum power dissipation the primary suppressor will not exceed the maximum voltage protection level. The MCP 120-OD Series are equipped with isolated, form-C relay contacts (C, NO, NC) that change state to show the suppressor operational status for each suppressor. LED indicators are provided on the face of each suppressor that illuminate to show Power On and Suppressor Operational. They are housed inside a pad lockable, non-metallic enclosure with a U.L. fire rating of 94-5V and a NEMA type 4X rating. These products are designed to attach in parallel with the load requiring protection. In the unlikely event that the suppressors are damaged, it is can easily be replaced or upgraded in the field. The MCP 120-OD Series is listed to UL 1449 2<sup>nd</sup> Edition.

**2.0 PERFORMANCE REQUIREMENTS:** Refer to each MCP product specification for specific details.

2.1 Electrical Service:

- 2.1.1 Service Voltage:.....120/240 and 120/208 VAC
- 2.1.2 Frequency: ..... 50/60 Hz
- 2.1.3 Phases:..... 1 and 3 Phase
- 2.1.4 Wiring Configuration: ..... 3 and 4-Wire
- 2.1.5 Maximum Continuous Operating Voltage: ..... 140/280 VRMS
- 2.1.6 Remote Relay Contact Rating:..... 3A/250VDC
- 2.1.7 Relay Contact to Coil Isolation:..... 3000V

2.2 Surge Performance:

- 2.2.1 Testing: Per ANSI/IEEE C62.45 1992, IEEE C62.41 1991 Wave Shapes

- 2.2.1.1 Location Category A: 6kV, 200A, 100kHz Ring Wave.
- 2.2.1.2 Location Category B3: 6kV, 500A, 100kHz Ring Wave and 6kV, 3kA Combination Wave.
- 2.2.1.3 Location Category C2: 10kV, 5kA Combination Wave, model MCP 120TA-5M-OD.
- 2.2.1.4 Location Category C3: 20kV, 10kA Combination Wave, model MCP 120TA-10M-OD.
- 2.2.1.5 Long Wave 10/1000 Stress Surge Per IEEE C62.41 1991 (Section 10.2 and Table 8).
- 2.2.1.6 Testing to IEC 61643-1, 120kA 8/20us surge current, model MCP 120W SASD/MOV

2.3 Mechanical: The construction and physical characteristics of the suppressors are as outlined herein. Refer to page 1 for a detailed mechanical sketch of the OD unit.

2.3.1 Enclosure Description: Each suppressor is housed inside a grey non-metallic NEMA type 4X enclosure rated to U.L. 94-5V. The overall dimensions are 11"H x 9"W x 6.25"D (179mm x 228mm x 159mm). The weight is 5.8lb (2.6kg).

2.3.2 Material: The material shall be as specified herein. However, when a definite material is not specified, the material utilized will enable each device to meet the performance requirements of this specification. Each enclosure is fabricated from a non-metallic fiberglass/polyester resin composite that can be drilled as required for installation purposes. The suppressors are comprised entirely of solid state devices.

**3.0 INSTALLATION REQUIREMENTS:** The installation of each suppressor is as outlined herein.

3.1 Electrical Connections:

3.1.1 Refer to the illustrations on pages 1, 4, and 5 in this document for electrical and mechanical mounting details.

3.1.2 A terminal block is provided within each enclosure for connecting the wire leads. Each terminal is marked for the appropriate phase and neutral leads, and GND is for the enclosure ground wire.

3.1.3 Refer to local and national electric codes for raceway requirements.  
WARNING! All electrical codes must be followed for installation.

3.2 Disconnect: Each suppressor is connected in parallel with the A.C. power source. A 20 amp, two (2) pole circuit breaker for 120/240VAC or a three (3) pole circuit breaker for 120/208VAC is recommended to be installed in series between each

suppressor assembly and the A.C. power source for fault protection. The circuit breaker wire terminations must accept #10 wires.

**4.0 ENVIRONMENTAL:**

4.1 Operating Temperature: .....-40° to +85° C

4.2 Storage Temperature: .....-40° to +85° C

4.3 Relative Humidity: ..... 90%

4.4 Ventilation: Each suppressor shall be installed in an area free from direct sun loading, with a maximum ambient temperature of +85° C.

**5.0 STATUS INDICATORS:** Each suppressor is provided with LED's and relay circuits to show the status of the unit during normal operation and fault conditions. The table below defines the operation of the indicators and relay circuits.

<u>Amber LED</u>	<u>Green LED</u>	<u>Relay Contact Connection</u>	<u>Definition of Problem</u>
Off	Off	C to NC	Electrical power is not applied.
On	Off	C to NC	Suppressor fault.
On	On	C to NO	Suppressor Operational.

INSTALLATION DIAGRAM FOR 120/240V, SINGLE Ø VOLTAGE

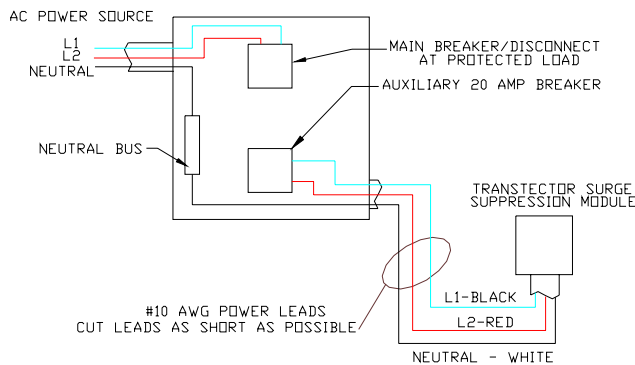

INSTALLATION DIAGRAM FOR 120/208V 3 PHASE VOLTAGE

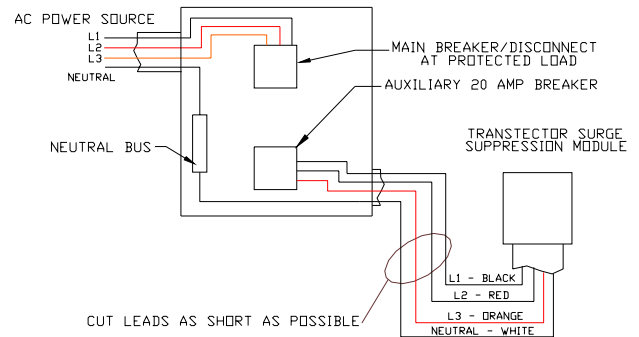

# INTERNAL VIEW AND RELAY CONTACTS INTERCONNECT TERMINAL BLOCK

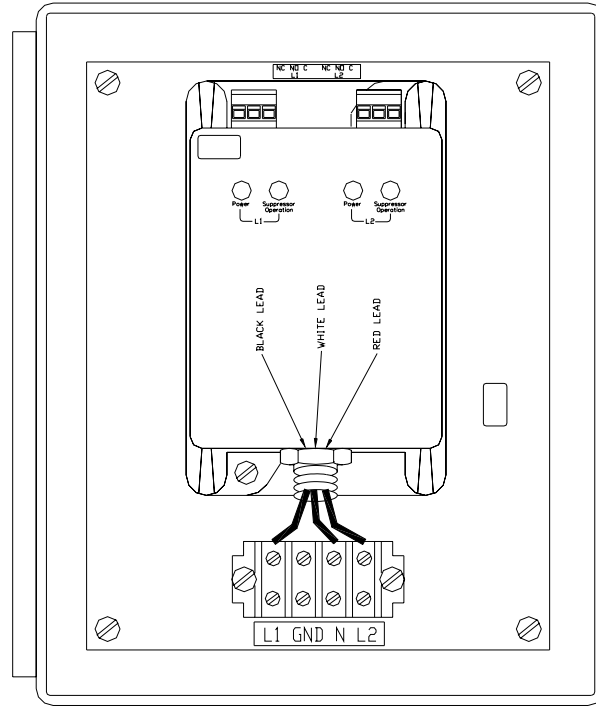

ENCLOSURE SHOWN WITH DOOR REMOVED

