



# DTK-120/240CM+

## 120/240VAC Surge Protective Device General Product Specifications

DITEK's 120/240CM+ is a durable, cost-effective SPD suitable for use in a variety of locations. It is typically used to protect pumps, motors, HVAC condensers, and incoming utility power. Backed by a ten year warranty, the DTK-120/240CM+ is an excellent choice for effective, economical protection.

### DTK-120/240CM+

#### Product Features

- Weatherproof enclosure
- Parallel connection for easy installation
- Diagnostic LED provides positive indication of power, ground presence, and surge protection
- Automatically resets to handle multiple surge events
- Typical Applications: A/C disconnect, small electrical panels, pool/well pumps
- Ten year limited warranty

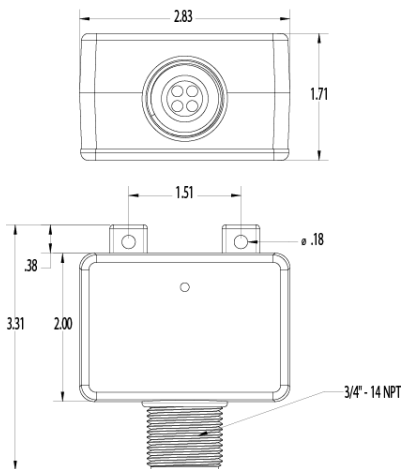

#### Specifications

**Agency Approvals:** UL 1449, 3<sup>rd</sup> Edition, cUL  
**Protector Type:** SPD Type 2  
**Protection Modes:** L-G, L-L  
**Response Time:** <1ns  
**Temperature Range:** -40°F – 185°F (-40°C – 85°C)  
**Maximum Humidity:** 95% non-condensing  
**Operating Frequency:** 0Hz – 400Hz  
**Dimensions:** 2.93" x 2.83" x 1.68"  
 (74.4mm x 71.9mm x 42.7mm)  
**Connection:** 3/4" threaded fitting  
**Weight:** .5lb. (227g)  
**Housing:** ABS

	Service Wiring	Peak Surge Current	MCOV	UL 1449, 3 <sup>rd</sup> Ed. V.P.R.	Short Circuit Current Rating	UL1449, 3 <sup>rd</sup> Ed. I <sub>n</sub> Rating
<b>DTK-120/240CM+</b>	Split $\Phi$ (2W + G), 120/240VAC	72,000A/Phase 36,000A/Mode	130/260V	500V L-G, 900V L-L	10,000A	10,000A