

Net-Contain™ Sliding Door Low Profile Cold Aisle Containment System for N-Type and S-Type Cabinets

Product Available December 15, 2012

specifications

The sliding door low profile aisle containment system shall create a structure including end of row doors and ceiling panels that enclose the cold aisle between rows of cabinets to segregate cold and hot air streams to and from equipment. This passive system shall contain no moving parts. Designed to contain the cold air, the system shall be deployed on raised floors. The system shall leverage existing data center cooling and equipment fans to move the flow of exhaust air and cooling air.

The system shall address heat loads up to 20kW per cabinet to enable dense server applications and eliminate data center hot spots versus conventional raised floor cooling systems that manage heat loads up to 7-8kW/cabinet. The modular system shall be capable of being added without disrupting existing in-cabinet equipment and cabling to enable a migration path.

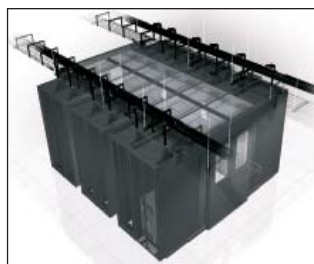

technical information

Integral Low Profile Ceiling Structure Dimensions:

Net-Access™ 800mm Cabinets:

4' (1200mm) aisle width:	C2CAC08F04IRB1*: 800mm W x 1200mm D
6' (1800mm) aisle width:	C2CAC08F06IRB1*: 800mm W x 1800mm D

Net-Access™ 700mm Cabinets:

4' (1200mm) aisle width:	C2CAC07F04IRB1*: 700mm W x 1200mm D
6' (1800mm) aisle width:	C2CAC07F06IRB1*: 700mm W x 1800mm D

Net-Access™ 600mm Cabinets:

4' (1200mm) aisle width:	C2CAC06F04IRB1*: 600mm W x 1200mm D
6' (1800mm) aisle width:	C2CAC06F06IRB1*: 600mm W x 1800mm D

End of row dual sliding doors:	6' (1800mm) aisle width: C2CACT5F06SDB1*: 2313mm H x 1800mm W
	4' (1200mm) aisle width: C2CACT5F04SDB1*: 2313mm H x 1800mm W

key features and benefits

Energy efficiency	Prevents hot spots and allows installation of high-density server cabinets close together in new builds or existing data centers reducing the need for extra real estate and CRAH units lowering operating costs
Optimized airflow distribution	Prevents mixing of cold and hot air streams; eliminates recirculation of hot air to cabinet inlets; provides uniform temperature at the inlets of IT equipment; prevents cold air bypass optimizing cool air delivery
Passive system	Contains no moving parts; provides more efficiency than fan driven products eliminating acoustical noise in the data center for improved system reliability
Improves thermal performance	Allows raising supply air set point temperature; higher return air temperature increases the thermal efficiency of cooling units reducing cooling energy cost up to 25 – 30%
Dual sliding door	Can be installed in either 4' (1200mm) or 6' (1800mm) aisle; mounts to Net-Access™ N-Type and S-Type Cabinets; damper system keeps doors from slamming closed and ensures the doors stay closed; uses gravity to automatically close doors ensuring network protection
Integral roofing	Available in 4' or 6' lengths of 600mm, 700mm, 800mm width roofing sections available; access holes allow fire suppression to enter the containment for improved safety and security
Wall panel roofing	600mm, 700mm, and 800mm wall panel for the roofing sections available

applications

The Net-Contain™ System separates cold and hot data center air streams to and from equipment. It manages airflow at the source, increases CRAH unit cooling efficiency, and significantly lowers operating expenses. The Net-Contain™ System leverages existing data center cooling and equipment fans to move the flow of exhaust air and cooling air, reducing energy costs and noise levels.

This passive system contains no moving parts, resulting in a more energy efficient solution than comparable forced-air options.

This integrated system is compatible with numerous Panduit product lines including: Net-Access™ N-Type and S-Type Cabinets, Net-SERV® Cabinets, CabRunner®, FiberRunner®, and Wyr-Grid® Overhead Cable Routing Systems.

www.panduit.com

Net-Contain™ Sliding Door Low Profile Cold Aisle Containment System

Integral Low Profile Ceiling Structures Net-Access™ 800mm Cabinets:

4' (1200mm) aisle width:	C2CAC08F04IRB1*
6' (1800mm) aisle width:	C2CAC08F06IRB1*

Net-Access™ 700mm Cabinets:

4' (1200mm) aisle width:	C2CAC07F04IRB1*
6' (1800mm) aisle width:	C2CAC07F06IRB1*

Net-Access™ 600mm Cabinets:

4' (1200mm) aisle width:	C2CAC06F04IRB1*
6' (1800mm) aisle width:	C2CAC06F06IRB1*

End of Row Dual Sliding Doors:

4' (1200mm) aisle width:	C2CACT5F04SDB1*
6' (1800mm) aisle width:	C2CACT5F06SDB1*

Net-Contain™ Integral Roof Wall Panel

800mm width:	C2CAC08F08WPB1*
700mm width:	C2CAC07F08WPB1*
600mm width:	C2CAC06F08WPB1*

Net-Access™ N-Type Cabinets

800mm x 45 RU x 1070mm

45 RU, front dual hinge door, rear perforated split doors, (2) side panels, cage nut rails, vertical blanking panels, cable management: N8512BU

45 RU, front dual hinge door, rear perforated split doors, cage nut rails, vertical blanking panels, cable management: N8519BU

800mm x 45 RU x 1200mm

45 RU, front dual hinge door, rear perforated split doors, (1) side panel, cage nut rails, vertical blanking panels, cable management: N8521BU

45 RU, front dual hinge door, rear perforated split doors, cage nut rails, vertical blanking panels, cable management: N8529BU

45 RU, front dual hinge door, rear perforated split doors, (2) side panels, cage nut rails, vertical blanking panels, cable management: N8522BU

800mm x 42 RU x 1070mm

42 RU, front dual hinge door, rear perforated split doors, cage nut rails, vertical blanking panels, cable management: N8219BU

42 RU, front dual hinge door, rear perforated split doors, (2) side panels, cage nut rails, vertical blanking panels, cable management: N8212BU

800mm x 42 RU x 1200mm

42 RU, front dual hinge door, rear perforated split doors, (2) side panels, #12-24 tapped rails, vertical blanking panels, cable management: N8222BM

42 RU, front dual hinge door, rear perforated split doors, #12-24 tapped rails, vertical blanking panels, cable management: N8229BM

Net-Access™ S-Type Cabinets

600mm x 42 RU x 1070mm

42 RU, single hinge perforated front door, rear perforated split doors, (2) side panels, casters, pou brackets, cage nut rails: S6212**

42 RU, single hinge perforated front door, rear perforated split doors, (2) side panels, casters, pou brackets, cage nut rails, zero RU QuickNet™ Style Vertical Patching Panels: S6212**P

Net-Contain™ Sliding Door Low Profile Cold Aisle Containment System for N-Type and S-Type Cabinets

integral low profile ceiling structures
for 4' (1200mm) aisle and for 6' (1800mm) aisle

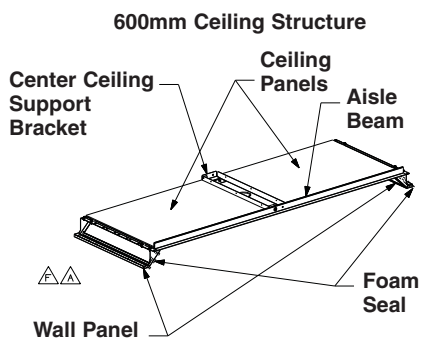
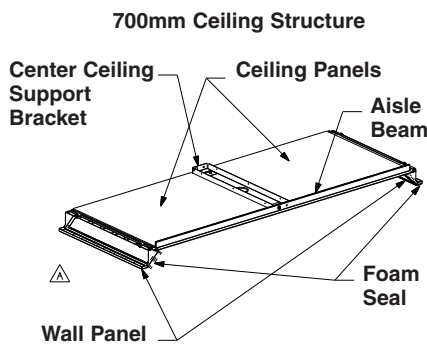
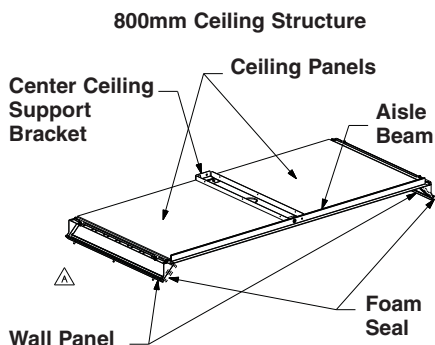

end of row dual sliding door

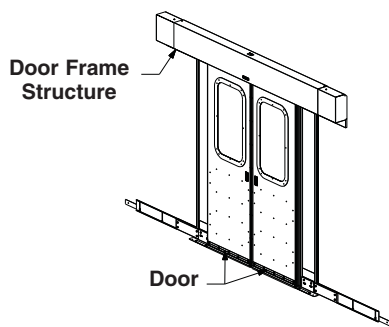

Open position



Uses gravity for automatic closure

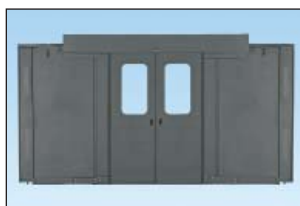

Closed position

Net-Access™ S-Type Cabinets

600mm x 45 RU x 1070mm	
45 RU, single hinge perforated front door, rear perforated split doors, (2) side panels, casters, pou brackets, cage nut rails:	S6512**
45 RU, single hinge perforated front door, rear perforated split doors, (2) side panels, casters, pou brackets, cage nut rails, zero RU QuickNet™ Style Vertical Patching Panels:	S6512**P
600mm x 42 RU x 1200mm	
42 RU, single hinge perforated front door, rear perforated split doors, (2) side panels, casters, pou brackets, cage nut rails:	S6222**
42 RU, single hinge perforated front door, rear perforated split doors, (2) side panels, casters, pou brackets, cage nut rails, zero RU QuickNet™ Style Vertical Patching Panels:	S6222**P
600mm x 45 RU x 1200mm	
45 RU, single hinge perforated front door, rear perforated split doors, (2) side panels, casters, pou brackets, cage nut rails:	S6522**
45 RU, single hinge perforated front door, rear perforated split doors, (2) side panels, casters, pou brackets, cage nut rails, zero RU QuickNet™ Style Vertical Patching Panels:	S6522**P
700mm x 42 RU x 1070mm	
42 RU, single hinge perforated front door, rear perforated split doors, (2) side panels, casters, pou brackets, cage nut rails:	S7212**
700mm x 45 RU x 1070mm	
45 RU, single hinge perforated front door, rear perforated split doors, (2) side panels, casters, pou brackets, cage nut rails:	S7512**
45 RU, single hinge perforated front door, rear perforated split doors, casters, pou brackets, cage nut rails:	S7519**
700mm x 42 RU x 1200mm	
42 RU, single hinge perforated front door, rear perforated split doors, (2) side panels, casters, pou brackets, cage nut rails:	S7222**
700mm x 45 RU x 1200mm	
45 RU, single hinge perforated front door, rear perforated split doors, (2) side panels, casters, pou brackets, cage nut rails:	S7522**
800mm x 42 RU x 1070mm	
42 RU, single hinge perforated front door, rear perforated split doors, (2) side panels, casters, pou brackets, cage nut rails:	S8212**
800mm x 45 RU x 1070mm	
45 RU, single hinge perforated front door, rear perforated split doors, (2) side panels, casters, pou brackets, cage nut rails:	S8512**
45 RU, single hinge perforated front door, rear perforated split doors, (2) side panels, casters, pou brackets, cage nut rails, cable management fingers:	S8512**F
800mm x 42 RU x 1200mm	
42 RU, single hinge perforated front door, rear perforated split doors, (2) side panels, casters, pou brackets, cage nut rails:	S8222**
800mm x 45 RU x 1200mm	
45 RU, single hinge perforated front door, rear perforated split doors, (2) side panels, casters, pou brackets, cage nut rails:	S8522**

* Indicates optional colors. Replace * with: B1= Black, W1= White
** Indicates optional colors. Replace * with: B= Black, W= White

WORLDWIDE SUBSIDIARIES AND SALES OFFICES

PANDUIT CANADA
Markham, Ontario
cs-cdn@panduit.com
Phone: 800.777.3300

PANDUIT EUROPE LTD.
London, UK
cs-emea@panduit.com
Phone: 44.20.8601.7200

PANDUIT SINGAPORE PTE. LTD.
Republic of Singapore
cs-ap@panduit.com
Phone: 65.6305.7575

PANDUIT JAPAN
Tokyo, Japan
cs-japan@panduit.com
Phone: 81.3.6863.6000

PANDUIT LATIN AMERICA
Guadalajara, Mexico
cs-la@panduit.com
Phone: 52.33.3777.6000

PANDUIT AUSTRALIA PTY. LTD.
Victoria, Australia
cs-aus@panduit.com
Phone: 61.3.9794.9020

For a copy of Panduit product warranties, log on to www.panduit.com/warranty

For more information

Visit us at www.panduit.com

Contact Customer Service by email: cs@panduit.com
or by phone: 800.777.3300 and reference RKSP107

PANDUIT®

©2012 Panduit Corp.
ALL RIGHTS RESERVED.
RKSP107--WW-ENG
10/2012