



HPX4-44-D3A/A

1.2 m | 4 ft High Performance Parabolic Shielded Antenna, dual-polarized, 4.400–5.000 GHz, PDR48, gray antenna, enhanced white radome with flash, standard pack—one-piece reflector

General Specifications

Packing	Standard pack
Radome Color	White
Radome Material	Enhanced
Reflector Construction	One-piece reflector
Antenna Input	PDR48
Antenna Color	Gray
Antenna Type	HPX - High Performance Parabolic Shielded Antenna, dual-polarized
Diameter, nominal	1.2 m 4 ft
Flash Included	Yes
Polarization	Dual

Electrical Specifications

Beamwidth, Horizontal	3.8 °
Beamwidth, Vertical	3.8 °
Cross Polarization Discrimination (XPD)	30 dB
Electrical Compliance	ETSI Class 2
Front-to-Back Ratio	56 dB
Gain, Low Band	30.0 dBi
Gain, Mid Band	32.6 dBi
Gain, Top Band	33.1 dBi
Operating Frequency Band	4.400 – 5.000 GHz
Radiation Pattern Envelope Reference (RPE)	LP864
Return Loss	26.4 dB
VSWR	1.10

Mechanical Specifications

Fine Azimuth Adjustment	±15°
Fine Elevation Adjustment	±20°
Mounting Pipe Diameter	115 mm 4.5 in
Net Weight	69 kg 152 lb
Side Struts, Included	1 inboard
Side Struts, Optional	1 inboard
Wind Velocity Operational	110 km/h 68 mph
Wind Velocity Survival Rating	200 km/h 124 mph

HPX4-44-D3A/A



Wind Forces At Wind Velocity Survival Rating

Angle α for MT Max	-130 °
Axial Force (FA)	3158 N 710 lbf
Side Force (FS)	1546 N 348 lbf
Twisting Moment (MT)	1072 N•m
Weight with 1/2 in (12 mm) Radial Ice	356 kg 784 lb
Zcg with 1/2 in (12 mm) Radial Ice	524 mm 21 in
Zcg without Ice	335 mm 13 in

HPX4-44-D3A/A



Wind Forces At Wind Velocity Survival Rating Image



Packed Dimensions

Gross Weight, Packed Antenna	168.0 kg 370.4 lb
Height	840.0 mm 33.1 in
Length	1430.0 mm 56.3 in
Volume	1.7 m ³
Width	1430.0 mm 56.3 in

Antenna Dimensions And Mounting Information

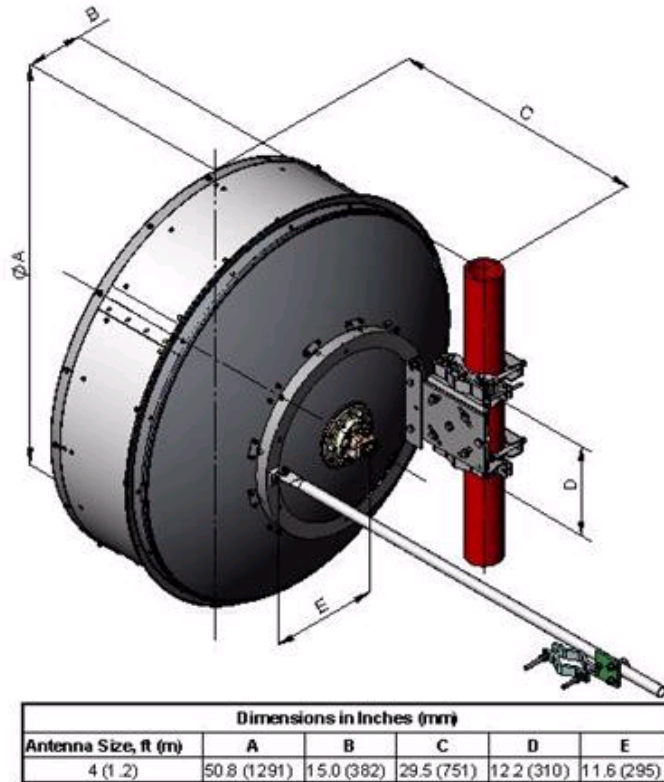

Regulatory Compliance/Certifications

Agency

ISO 9001:2008

Classification

Designed, manufactured and/or distributed under this quality management system

* Footnotes

Axial Force (FA)

Maximum forces exerted on a supporting structure as a result of wind from the most critical direction for this parameter. The individual maximums specified may not occur simultaneously. All forces are referenced to the mounting pipe.

Cross Polarization Discrimination (XPD)

The difference between the peak of the co-polarized main beam and the maximum cross-polarized signal over an angle twice the 3 dB beamwidth of the co-polarized main beam.

Front-to-Back Ratio

Denotes highest radiation relative to the main beam, at $180^\circ \pm 40^\circ$, across the band. Production antennas do not exceed rated values by more than 2 dB unless stated otherwise.

Gain, Mid Band

For a given frequency band, gain is primarily a function of antenna size. The gain of Andrew antennas is determined by either gain by comparison or by computer integration of the measured antenna patterns.



HPX4-44-D3A/A

Operating Frequency Band	Bands correspond with CCIR recommendations or common allocations used throughout the world. Other ranges can be accommodated on special order.
Packing	Andrew standard packing is suitable for export. Antennas are shipped as standard in totally recyclable cardboard or wire-bound crates (dependent on product). For your convenience, Andrew offers heavy duty export packing options.
Radiation Pattern Envelope Reference (RPE)	Radiation patterns determine an antenna's ability to discriminate against unwanted signals under conditions of radio congestion. Radiation patterns are dependent on antenna series, size, and frequency.
Return Loss	The figure that indicates the proportion of radio waves incident upon the antenna that are rejected as a ratio of those that are accepted.
Side Force (FS)	Maximum side force exerted on the mounting pipe as a result of wind from the most critical direction for this parameter. The individual maximums specified may not occur simultaneously. All forces are referenced to the mounting pipe.
Twisting Moment (MT)	Maximum forces exerted on a supporting structure as a result of wind from the most critical direction for this parameter. The individual maximums specified may not occur simultaneously. All forces are referenced to the mounting pipe.
VSWR	Maximum; is the guaranteed Peak Voltage-Standing-Wave-Ratio within the operating band.
Wind Velocity Operational	The wind speed where the antenna deflection is equal to or less than 0.1 degrees. In the case of ValuLine antennas, it is defined as a maximum deflection of 0.3 x the 3 dB beam width of the antenna.
Wind Velocity Survival Rating	The maximum wind speed the antenna, including mounts and radomes, where applicable, will withstand without permanent deformation. Realignment may be required. This wind speed is applicable to antenna with the specified amount of radial ice.