

SENTROL

ShatterPro™ II Advanced Acoustic Sensor with Pattern Recognition Technology™

Protected under U.S. Patent 5,192,931 and 5,510,767

Installation Instructions for Recessed and Surface Mount Models

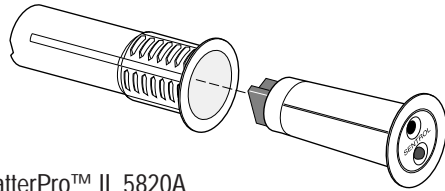

Recessed ShatterPro™ II 5820A

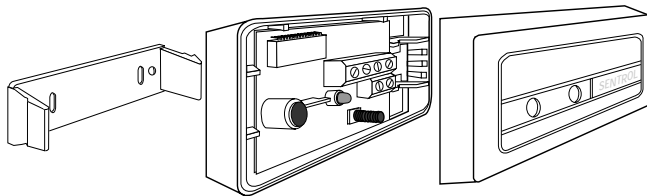

Surface Mount ShatterPro™ II 5812A

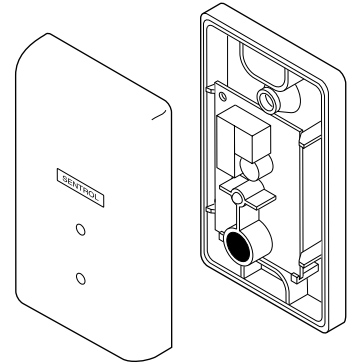

Surface Mount ShatterPro™ II 5812EZ

WIRING

Strip back the outer jacket on your wiring cable. This will allow wires to flex in the case. Make sure the cable is slack in the wall to avoid stressing the wires at their connections.



5812EZ-W
5812A-W

spring clip for latching LED

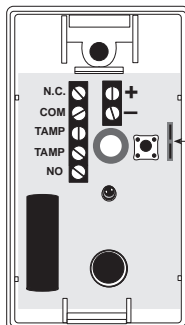

5815EZ-W
5815A-W

spring clip for latching LED

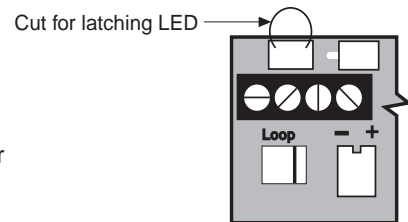

5820A-W and 5822A-W

NOTE: When wiring the 5822A, the tamper is in series with the alarm loop. There is insufficient room for a separate set of terminals for the tamper.

ORDERING INFORMATION

Description	Model No.	Color	Listing
ShatterPro™ II EZ, tamper, latch or non-latch LED	5812EZ-W	White	UL
ShatterPro™ II EZ, tamper, Form C, latch or non-latch LED	5815EZ-W	White	ULC
ShatterPro™ II, tamper, latch or non-latch LED	5812A-W	White	UL
ShatterPro™ II, tamper, Form C, latch or non-latch LED	5815A-W	White	ULC
Recessed ShatterPro™ II, latch or non-latch LED	5820A-W	White	
Recessed ShatterPro™ II, tamper, latch or non-latch LED	5822A-W	White	UL
Single Gang Box ShatterPro™ II	5825A-W	White	
Single Gang Box Kit for Recessed ShatterPro™ II	5829A-W	White	
Hand-held Tester, for testing effective range	5709C-W	White	

RANGE OF COVERAGE

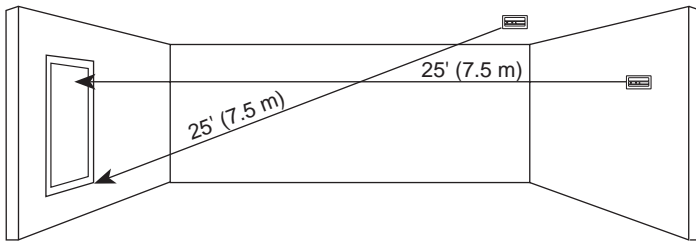

The ShatterPro sensors are omni-directional, providing 360° coverage. Coverage is measured from the sensor to the point on the glass farthest from the sensor. The sensor can be mounted as close as 3.3' (1 m) from the glass.

1. Mounted on opposite wall or adjoining walls, range is 25 ft. (7.5m) for plate, tempered, laminated and wired glass.
2. Mounted on the ceiling, maximum range is 25 ft. (7.5m) for plate, tempered, laminated and wired glass.
3. For armor-coated glass, mount sensor no more than 12 ft. (3.65m) from glass.

Recommended Glass Size:

Minimum 1' x 2' (0.3 m x 0.6 m) or larger

Glass thickness:

- Plate: 3/32" to 1/4" (2.4 mm to 6.4 mm)
- Tempered: 1/8" to 1/4" (3.2 mm to 6.4 mm)
- Wired: 1/4" (6.4 mm)
- Laminated: 1/8" to 1/4" (3.2 mm to 6.4 mm)

For Best Detection, Avoid Installing In:

- Rooms with lined, insulating, or sound deadening drapes.
- Rooms with closed wooden window shutters inside.

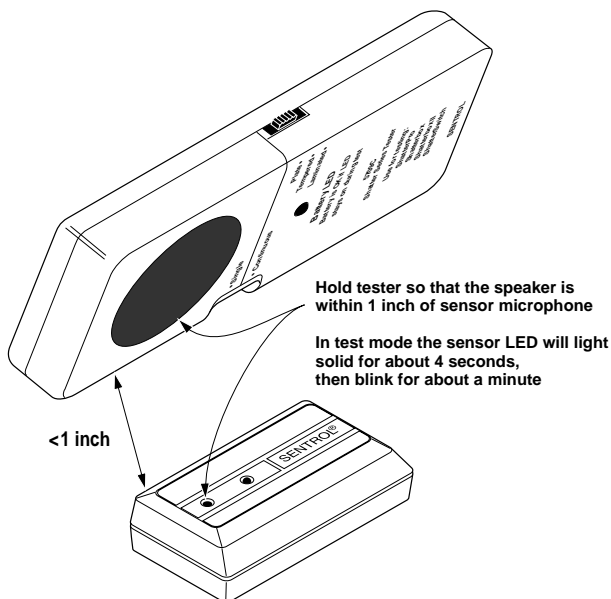

TESTING THE SENSOR

Put Sensor in Test Mode

1. Connect 9-volt battery to sensor for pre-testing.
2. Use double-stick tape provided to temporarily mount sensor in desired location.
3. Use Sentrol 5709C Hand-Held Tester to put sensor into test mode. Set tester to "tempered glass" and hold on top of sensor. Activate tester — this will trip sensor into test mode for one minute. In test mode, LED will blink continuously. To extend test time, activate tester at least once a minute.

Test the Sensor (sensor must be in test mode, blinking)

1. The 5709C tester has settings for different types of glass. Use "tempered" setting if unsure of glass type.
2. Hold tester near surface of glass to be protected and aim at sensor. Press test button.
If drapes or blinds are present, hold the tester behind the closed drapes or blinds.
3. If LED stays on for four seconds, glass is within detection range of sensor.
4. If LED does not stay on, reposition the sensor and retest. (Verify adequate battery strength in tester.)
5. For latching LED: open the spring clip and provide a power reset by removing power and resetting the LED.

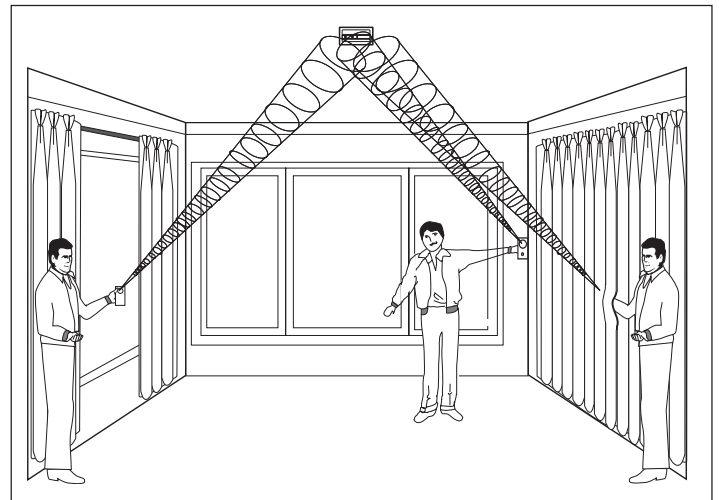

How Test Mode Works:

Test Mode is activated by the hand-held tester when the tester is held directly over the microphone and set off. The sensor's LED will blink continuously for 1 minute. During this time, the installer can test the unit using the instructions above. When the system is armed and the ShatterPro II trips to an alarm condition, the LED will latch solid for 4 seconds and then revert back to a 1 minute test mode. At the end of one minute, the LED will extinguish if in "set up LED" mode, or the LED will latch if set for "Latching LED." Open spring clip for Latching LED.

MOUNTING

Locate sensor at least 4' from noise sources (TVs, speakers, sinks, doors, etc.), and at least 3.3' away from nearest point of glass to be protected.

Sensor location should be in direct line of sight of glass to be protected.

Surface Mount

Wall Mounting

The best location for mounting the sensor is on the opposite wall — assuming the glass to be protected is within the sensor's range and line of sight (see figure). The ceiling and adjoining (side) walls are also good sensor locations.

Ceiling Mounting

Mount the sensor in any type of ceiling in a location which is in direct line of sight of the windows to be protected. However, since sound travels directionally out from the broken window, a position 8' (2.4 m) into the room provides better detection (see figure).

Recessed

Wall or Ceiling Mount

- Drill 1" (2.5 cm) hole. (Spade bit makes cleaner hole than twist bit.) (Drill 1-1/16" (2.7 cm) hole for hard woods.)
- Run wires through hole.
- Connect wires to terminal as shown in wiring diagrams.
- Do not install in rooms with ultrasonic sensors.

Pre-Wire Installation for the 5812EZ

Single Gang Box

1. Place the 5811EZ trim plate accessory over the single gang box.
2. Route wire through wire entry hole.
3. Mount the sensor to the single gang box using the screw holes that align to the gang box.
4. Attach wires to terminal strip and snap front cover in place.

AVOIDING FALSE ALARMS

Areas to Avoid:

- Glass airlocks and glass vestibule areas
- Kitchens
- Corner mounting
- Residential car garages
- Small utility rooms
- Stairwells
- Bathrooms
- Other small acoustically live rooms

For glassbreak protection in such applications, use Sentrol shock or ShatterPoint (model 5600, 5620) sensors on the windows or window frames.

Do Not Install In Humid Rooms

No glassbreak sensor is hermetically sealed. Excess moisture on the circuit board can eventually cause a short and a false alarm.

For Best False Alarm Immunity:

- Avoid 24-hour loop applications (perimeter loop OK).
- Don't use where white noise, such as air compressor noise, is present. (A blast of compressed air may cause a false alarm.)
- Avoid rooms smaller than 10' x 10' (3 m x 3 m) and rooms with multiple noise sources such as kitchens, glass booths, noisy areas, garages, bathrooms, etc.
- In rooms less than 10' x 10', use a reduced-range ShatterPro™ II, (models 5820A-W2, 5812A-W2), or ShatterPoint (model 5600, 5620).

Proper Testing

The ShatterPro II is designed to detect the breaking of framed glass mounted in an outside wall. Testing the sensor with unframed glass, broken bottles, etc., may not trip the sensor. The ShatterPro II typically does not trip to glass breaking in the middle of the room. No burglar breaks glass in the middle of a room, so such breaks are false alarms.

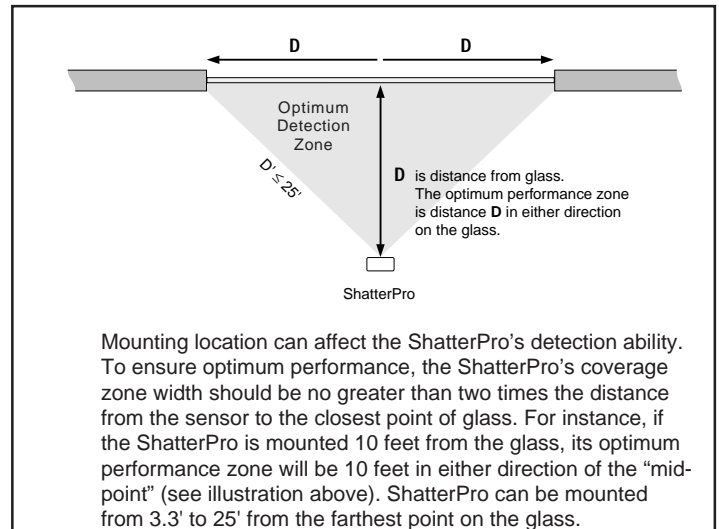

Avoid 24-Hour Loop Applications

The ShatterPro II is recommended for perimeter loops and is designed to function in occupied areas. In 24-hour loop applications, where the sensor is armed all day and all night, the false alarm technology will be pushed to its limit. Some sounds can duplicate the points on the glassbreak pattern the ShatterPro II detects.

Install the ShatterPro II on a perimeter loop which is armed whenever the door and window contacts are armed.

Protecting Occupied Areas

The ShatterPro II's false alarm immunity is best in rooms with only moderate noise. For 24-hour occupied area protection, use Sentrol shock sensors or the ShatterPro™ Plus 5885 or ShatterPoint (5600, 5620).

NOTE: ShatterPro II may not consistently detect cracks in glass, or bullets which break through the glass. Glassbreak sensors should always be complemented with interior protection.

Connection to Panel

The ShatterPro II should be connected to a UL Listed control panel, or a power supply that provides at least four hours of standby power.

SPECIFICATIONS

Electrical

Voltage	9 to 16 VDC
Current	12 mA typical, 25 mA max.
Relay output	Normally closed, open 4 seconds upon alarm
On resistance	10 Ohm - 5 +10
Off resistance	> 1 MOhms
Maximum loop rating (relay or tamper loop)	
.....	16 VDC, 50 mA
Wiring terminals	22-18 AWG

Environmental

Lightning suppression	400 watts for 1 msec pulse
RF Immunity	20V/m min from 1MHz to 1GHz
Microphone	Omni-directional electret
Operating Temperature	0° F to 120° F (-18° C to +50° C)
Humidity	10% to 90% noncondensing

NOTE: This equipment has been tested and found to comply with the limits for a Class B digital device, pursuant to Part 15 of the FCC Rules. These limits are designed to provide reasonable protection against harmful interference in a residential installation. This equipment generates, uses and can radiate radio frequency energy and, if not installed and used in accordance with the instructions, may cause harmful interference to radio communications. There is no guarantee that interference will not occur in a particular installation. If this equipment does cause harmful interference to radio or television reception, which can be determined by turning the equipment on and off, the user is encouraged to try to correct the interference by one or more of the following measures:

- Re-orient or relocate the receiving antenna.
- Increase the separation between the equipment and receiver.
- Connect the equipment into an outlet on a circuit different from that to which the receiver is connected.
- Consult the dealer or an experienced radio/TV technician for help.

Under FCC Rules, Part 15 for Class B digital devices, operation is subject to the following two conditions:

- 1) This device may not cause harmful interference.
- 2) This device must accept any interference received, including interference that may cause undesired operation.

ACCESSORIES

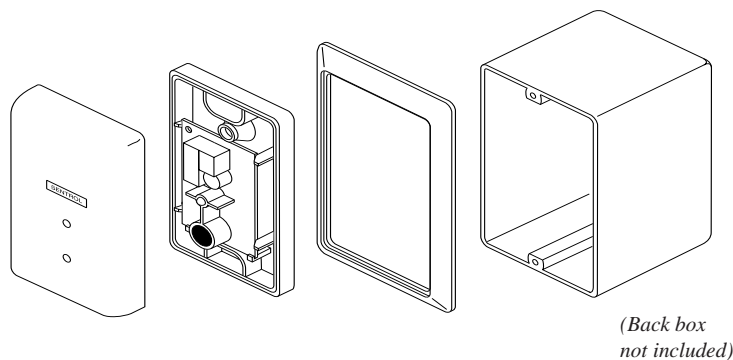
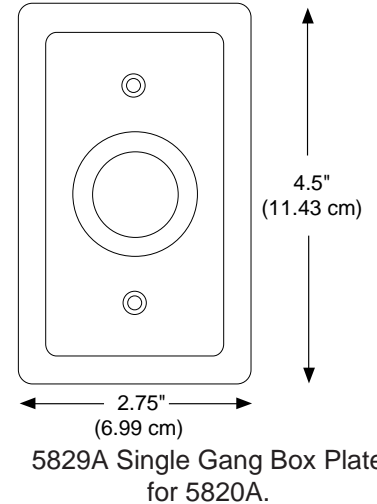
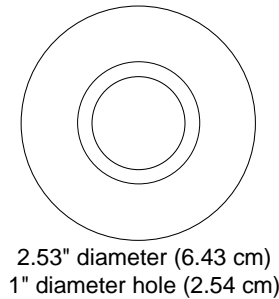
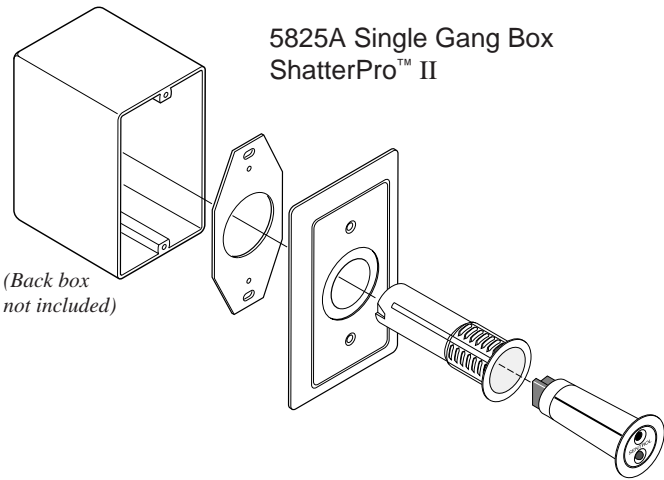

5812EZ Pre-Wire Installation with 5811EZ and Single Gang Box



SENTROL

CORPORATE HEADQUARTERS
12345 SW Leveton Dr., Tualatin, OR 97062
Tel.: 503.692.4052 Fax: 503.691.7566
<http://www.sentrol.com>
U.S. & Canada: 800.547.2556
Technical Service: 800.648.7424
FaxBack: 800.483.2495

Sentrol reserves the right to change specifications without notice.

©1998 Sentrol

G-3513-798
15651 Rev. A