

REV	MCO	DWN	DATE
C	20237383	LS	08-APR-08
D	20252817	LS	04-NOV-08

NOTES:

1.0 SCOPE

THIS SPECIFICATION DEFINES THE REQUIREMENTS FOR A WALL PLATE MODULAR 2 PORTS

2.0 APPLICABLE DOCUMENTS

- 2.1 UL 94 "TESTS FOR FLAMMABILITY OF PLASTIC MATERIALS"
- 2.2 ORDER OF PRECEDENCE

IN CASE OF CONFLICT, THE FOLLOWING ORDER OF PRECEDENCE SHALL APPLY:

- A. PURCHASE ORDER
- B. THIS DOCUMENT

3.0 REQUIREMENTS

- 3.1 MATERIALS
 - 3.1.1 MATERIAL: ABS POLYLAC PA-765A OR EQUIVALENT.
 - 3.1.2 COLOR: SEE TAB
- 3.2 DIMENSIONAL
 - 3.2.1 SEE DRAWING
 - 3.2.2 PART TO BE FREE OF BURRS, SCRATCHES, SPOTS AND NOTICEABLE SINK.
- 3.3 FLAMMABILITY:
 - 3.3.1 FLAMMABILITY RATING: MATERIAL USED SHALL BE UL94 V-0 LISTED.

4.0 QUALITY ASSURANCE PROVISIONS:

- 4.1 MANUFACTURING INSPECTION:
 - THE MANUFACTURER SHALL PREFORM AUDITS TO ENSURE 100% FUNCTIONALITY OF ALL RECEIVED PARTS. ADDITIONAL TESTING AND INSPECTIONS SHALL BE PREFORMED AS NEEDED TO ENSURE THAT ALL REQUIREMENTS ARE MET.

- 4.2 QUALITY CONFORMANCE INSPECTION
 - BUYER RESERVES THE RIGHT TO RETURN AT THE MANUFACTURER'S EXPENSE ANY NONCONFORMING MATERIALS OR LOTS WHICH DO NOT MEET SAMPLING INSPECTION REQUIREMENTS.

- 4.3 DESIGN AND PROCESS CHANGE:
 - NO CHANGES IN MATERIAL DESIGN OR PROCESS WHICH WILL AFFECT FORM, FIT OR FUNCTION SHALL BE MADE BY THE MANUFACTURER AFTER SAMPLE APPROVAL WITHOUT WRITTEN AUTHORITY FROM THE BUYER. THE TERM "FUNCTIONAL" IMPLIES SECTION 3.0 PARAMETERS.

5.0 PACKAGING AND HANDLING REQUIREMENTS:

- 5.1 MAXIMUM CONTAINER WEIGHT: 40 LBS.
- 5.2 SHIPPING CONTAINER MARKING(S)

SHIPPING CONTAINERS SHALL BE MARKED WITH THE FOLLOWING AS A MINIMUM:

- 1. MANUFACTURER'S NAME AND/OR LOGO
- 2. ADC PART NUMBER
- 3. ADC PURCHASE ORDER NUMBER
- 4. QUANTITY ENCLOSED
- 5. (PREFERRED BUT OPTIONAL INFORMATION):
 - NUMBER OF SEPARATE PACKAGES/BOXES
 - ("BOX# ---- OF ---- BOXES")

ADC P/N	CATALOG	REV	COMPONENT F/N 001 (DESCRIPTION) QTY 1	COMPONENT F/N 002 (DESCRIPTION) QTY 1	COMPONENT F/N 003 (DESCRIPTION) QTY 1	COMPONENT F/N 004 WALL PLATE, MODULAR 2 PORT (COLOR) QTY 1	PANTONE COLOR	FEDERAL STANDAR SPECIFICATION	COMPONENT F/N 005 POLYBAG, ID TABS & DESIGNATION (COLOR) QTY 1
6644115201	6644 1 152-01	B	PA111 0212 00 00 POLYBAG CLEAR 5X9 IN. .002 THICK	6630 3 105-00 POLYBAG W/2 #6 - 32x15/16 COMBO SCREWS	1436364 INSTRUCTION SHEET 2 PORT WALL PLATE MODULAR	6644 3 152-01 (WHITE)	---	FED STD. 37925	6630 3 112-01 (WHITE)
6644115202	6644 1 152-02	B				6644 3 152-02 (IVORY)	---	FED STD. 27886	6630 3 112-02 (IVORY)
6644115203	6644 1 152-03	B				6644 3 152-03 (GRAY)	421C	FED STD. 25630	6630 3 112-03 (GRAY)
6644115204	6644 1 152-04	B				6644 3 152-04 (BLACK)	6C2X	FED STD 27038	6630 3 112-04 (BLACK)
6644115205	6644 1 152-05	B				6644 3 152-05 (RED)	187C	FED STD 11350	6630 3 112-05 (RED)
1437624	6644 1 152-06	B				6644 3 152-06 (BLUE)	291C	FED STD 15180	6630 3 112-06 (BLUE)
1437625	6644 1 152-07	B				6644 3 152-07 (GREEN)	343C	FED STD 14109	6630 3 112-07 (GREEN)
1437627	6644 1 152-08	B				6644 3 152-08 (YELLOW)	106C	FED STD 13591	6630 3 112-08 (YELLOW)
6644115222	6644 1 152-22	B				6644 3 152-22 (ELECTRICAL IVORY)	4545U	---	6630 3 112-22 (ELECTRICAL IVORY)
1458406	6644 1 152-24	A				6644 3 152-24 (ELECTRICAL BROWN)	440C	---	6630 3 112-24 (ELECTRICAL BROWN)

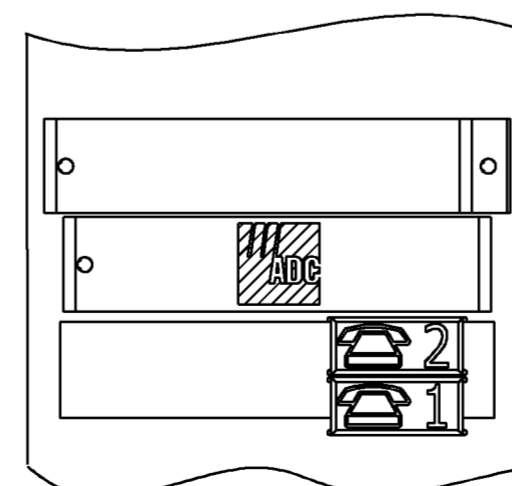
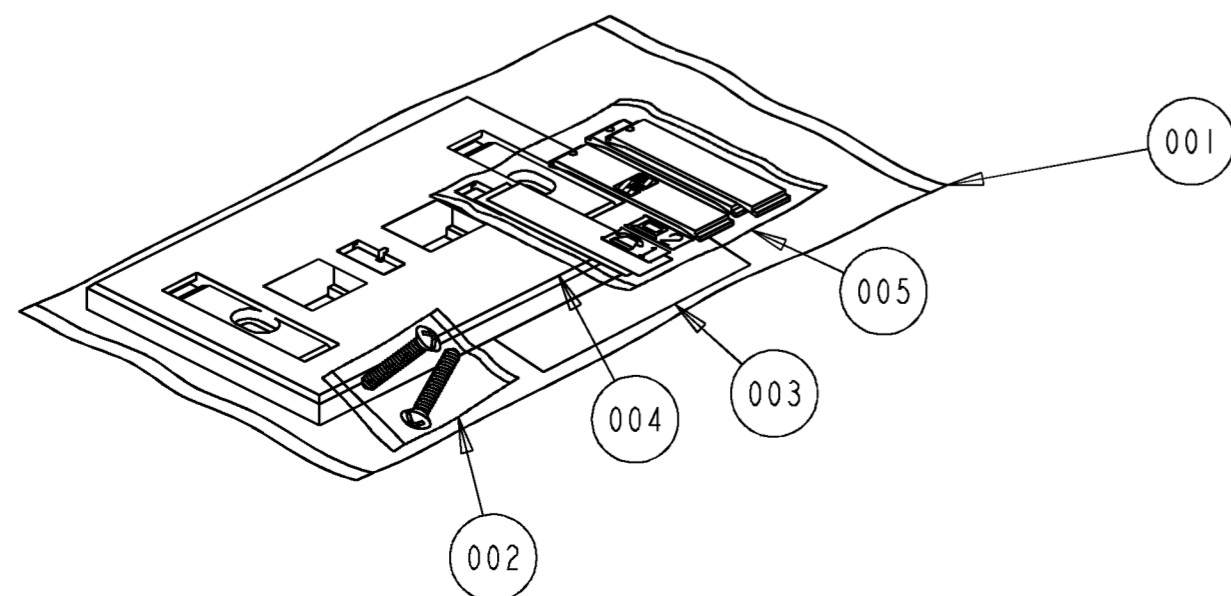

F/N 005 DETAIL



INFORMATION ON THIS DOCUMENT IS PROPRIETARY TO ADC AND SHALL NOT BE USED, COPIED, REPRODUCED OR DISCLOSED IN WHOLE OR IN PART WITHOUT WRITTEN CONSENT OF ADC.		TITLE ASSY WALL PLATE MODULAR 2 PORT COLOR XX	
ALL DIMS AND TOLERANCES ARE INCHES UNLESS OTHERWISE SPECIFIED	.XX:±N/A .XXX:±N/A ANGULAR:±N/A	C SIZE	DRAWING NUMBER 66441152XX
DO NOT SCALE DRAWING		ENGR: LUIS SANCHEZ DWN: LUIS SANCHEZ	SHT. 1 OF 1

**DIMENSIONS IN INCHES
THIRD ANGLE PROJECTION**