

4

3

2

1

THIS DRAWING IS UNPUBLISHED. RELEASED FOR PUBLICATION 20
 © COPYRIGHT 20 BY TYCO ELECTRONICS CORPORATION. ALL RIGHTS RESERVED.

LOC	DIST	REVISIONS			
P	LTR	DESCRIPTION	DATE	DWN	APVD
	D	REDWN, REV; EC 0B40-0029-03	24MAR03	GG	FL
	E	REV ECO-09-026267	04DEC09	LH	SJ

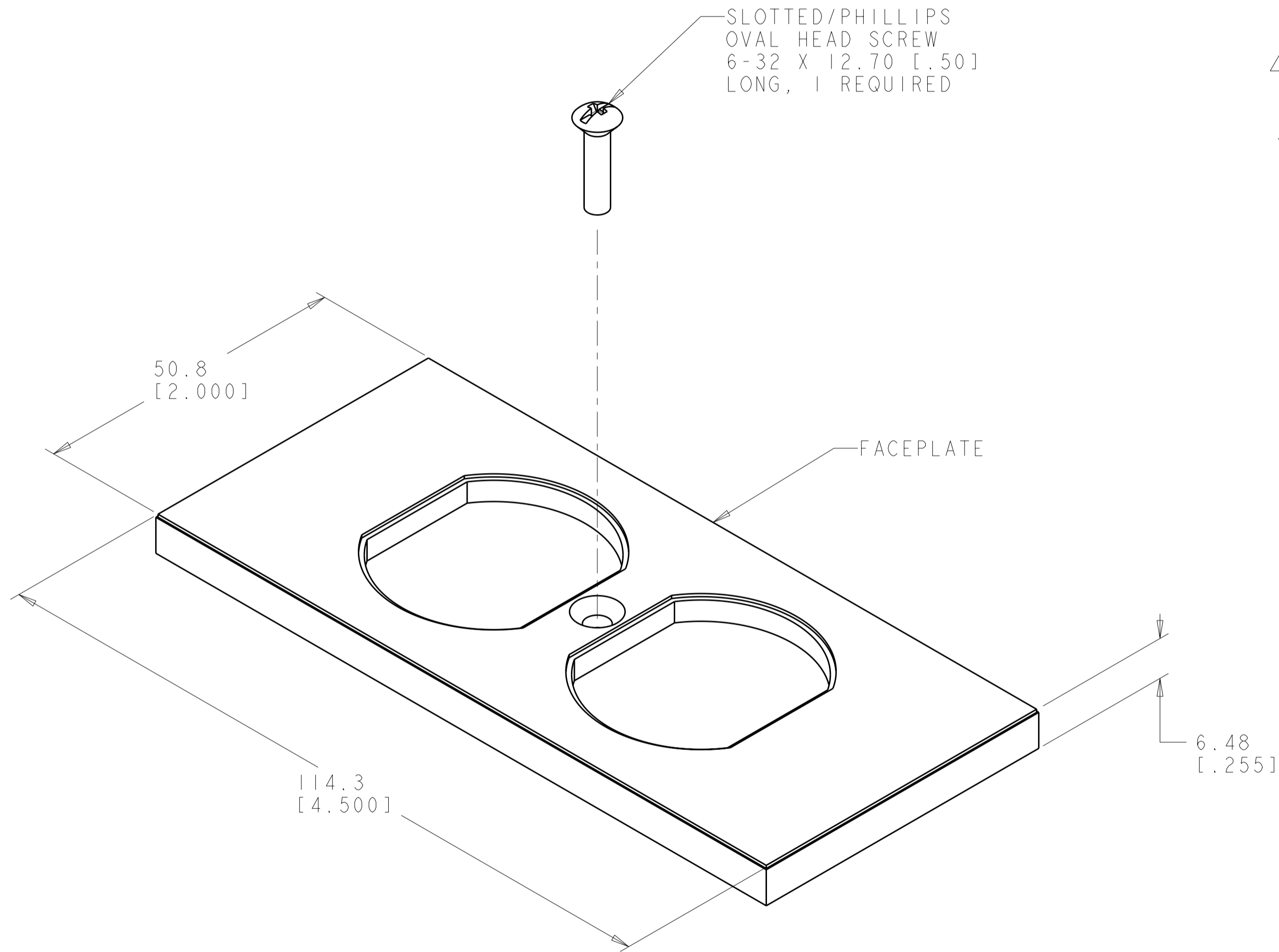

- 1 MATERIAL: FACEPLATE - POLYCARBONATE MOLDING COMPOUND 94V-0 RATED, SEE TABLE FOR COLOR. SCREWS - ZINC PLATED CARBON STEEL WITH PAINTED HEADS.
- 2 DIMENSIONS ARE MAXIMUM UNLESS OTHERWISE SPECIFIED.
- 3 APPLICATION: FOR USE WITH ACCESS FLOOR WORKSTATION MODULES (AFWM). FACEPLATE ACCEPTS ONE COMMERCIALY AVAILABLE STANDARD DUPLEX RECEPTACLE.

WHITE	769028-5
GRAY	769028-4
LIGHT ALMOND	769028-1
COLOR	PART NUMBER

THIS DRAWING IS A CONTROLLED DOCUMENT FOR TYCO ELECTRONICS CORPORATION. IT IS SUBJECT TO CHANGE AND THE CONTROLLING ENGINEERING ORGANIZATION SHOULD BE CONTACTED FOR THE LATEST REVISION.		DWN G. GARRETT 24MAR03	Tyco Electronics Harrisburg, PA 17105-3608
DIMENSIONS: MM [INCHES]		CHK E. LINCOLN 24MAR03	
TOLERANCES UNLESS OTHERWISE SPECIFIED:		APVD E. LINCOLN 24MAR03	
0 PLC ± 1 PLC ± 2 PLC ± 3 PLC ± 4 PLC ± ANGLES ± FINISH		PRODUCT SPEC APPLICATION SPEC WEIGHT 14 GRAMS CUSTOMER DRAWING	
MATERIAL 		NAME FACEPLATE KIT, AFWM, STANDARD DUPLEX	SIZE A2
		CAGE CODE 00779	DRAWING NO 769028
		SCALE 2:1	SHEET OF REV 1 OF 1 E