

# INSTRUCTION MANUAL

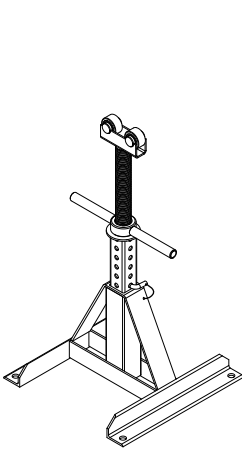

**687**

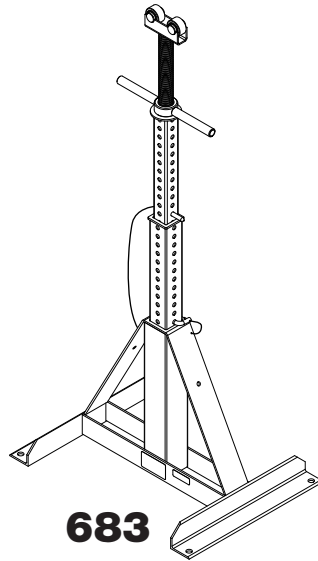

**683**

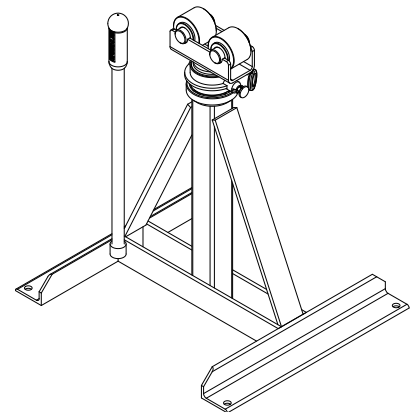

**656**

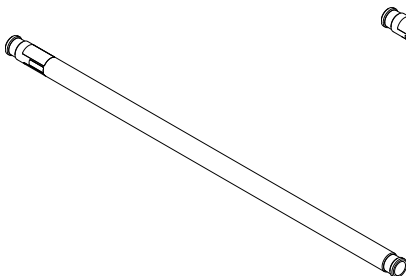

**647**

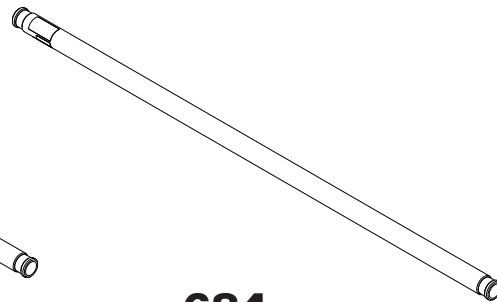

**684**

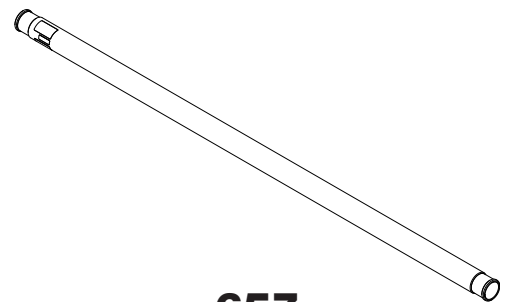

**657**

## Reel Stands and Spindles



**Read and understand** all of the instructions and safety information in this manual before operating or servicing this tool.

## Table of Contents

Description .....	2
Safety .....	2
Purpose of this Manual .....	2
Important Safety Information .....	3
Specifications .....	4
Repair Parts.....	4
Maintenance.....	4
Operation.....	4

## Description

The Greenlee 687, 683 and 656 Reel Stands and 647, 684 and 657 Reel Spindles are intended for dispensing of cable from cable reels.

## Safety

Safety is essential in the use and maintenance of Greenlee tools and equipment. This manual and any markings on the tool provide information for avoiding hazards and unsafe practices related to the use of this tool. Observe all of the safety information provided.

## Purpose of this Manual

This manual is intended to familiarize all personnel with the safe operation and maintenance procedures for the following Greenlee tools:

- 687 Reel Stand
- 683 Reel Stand
- 656 Reel Stand
- 647 Reel Spindle
- 684 Reel Spindle
- 657 Reel Spindle

Keep this manual available to all personnel.

Replacement manuals are available upon request at no charge.

All specifications are nominal and may change as design improvements occur. Greenlee Textron Inc. shall not be liable for damages resulting from misapplication or misuse of its products.

# ***KEEP THIS MANUAL***

## IMPORTANT SAFETY INFORMATION



### SAFETY ALERT SYMBOL

This symbol is used to call your attention to hazards or unsafe practices which could result in an injury or property damage. The signal word, defined below, indicates the severity of the hazard. The message after the signal word provides information for preventing or avoiding the hazard.

#### ⚠️ DANGER

Immediate hazards which, if not avoided, **WILL** result in severe injury or death.

#### ⚠️ WARNING

Hazards which, if not avoided, **COULD** result in severe injury or death.

#### ⚠️ CAUTION

Hazards or unsafe practices which, if not avoided, **MAY** result in injury or property damage.

#### ⚠️ CAUTION

- Make sure bystanders are clear of the work area when loading, unloading or dispensing cable. Nearby personnel can be injured if a cable reel escapes.
  - Do not use the reel roller for cable with damaged reels. Damaged reels may not roll freely and may be pulled off the reel roller.
  - Cable reels must be chocked at all contact points with the ground to prevent movement during setup.
  - The proper Greenlee spindle is required for safe operation of this tool. Do not use anything else—substitutes may not support the cable reel or may fall off the reel stand.
  - Never attach casters or wheels to a Greenlee Reel Stand.
  - Use only on a hard, flat, level surface.
  - Do not exceed the rated capacity of this tool.
- Failure to observe these precautions may result in injury or property damage.

#### ⚠️ CAUTION

Use this tool for manufacturer's intended use only. Use other than that which is described in this manuals may result in injury or property damage.



#### ⚠️ CAUTION

Read and understand all of the instructions and safety information in this manual before operating or servicing this tool.

Failure to observe this precaution may result in injury or property damage.

*Note: Keep all decals clean and legible, and replace when necessary.*



#### ⚠️ CAUTION

- Keep hands and feet clear when loading and unloading cable reels.
- Cable reels must be chocked at all contact points with the ground to prevent movement during setup.

Failure to observe these precautions may result in injury or property damage.

## Specifications

Cat. No.	Capacity	Max Height	Base Dimensions	Weight	Max Reel Diameter	Spindle	Size	Weight	Max Reel Width
687	2500 lb ea (1134 kg)	28" (711 mm)	15" x 15" (381 x 381 mm)	22 lb (10 kg)	56" (1422 mm)	647	Ø2-3/8" x 62" (60 x 1575 mm)	42 lb (19 kg)	47" (1194 mm)
683		54" (1372 mm)	21" x 24" (457 x 610 mm)	40 lb (18 kg)	96" (2438 mm)	684	Ø2-3/8" x 76" (60 x 1930 mm)	50 lb (23 kg)	61" (1549 mm)
656	3750 lb ea (1701 kg)	46-5/8" (1184 mm)	23" x 24.5" (533 x 622 mm)	86 lb (39 kg)	90" (2286 mm)	657	Ø3-1/2" x 100" (89 x 2540 mm)	124 lb (56 kg)	88" (2235 mm)

## Repair Parts

- 50302914 ..... Handle with grip (656)
- 50302965 ..... Pawl (656)
- 90532759 ..... Spring (656)
- 50303074 ..... Knob (656)
- 90532414 ..... Driv-Lok Pin (656)
- 50255916 ..... Stop pin (687-1, 683,2)

## Maintenance Procedure

Grease rollers on the 656 Reel Stand prior to each setup.  
Use zerks in center of roller axles.

## Operation

1. Two alike Reel Stands and one Greenlee Reel Stand Spindle are required for a complete setup.  
(The 687 and 683 Reel Stands must be used with only the 647 or 684 Spindles. The 656 Reel Stand must be used with only the 657 Spindle.)
2. Make sure the cable reel is chocked to prevent movement during setup.
3. Position the Spindle through the center holes of the cable reel. (Fig. 1)

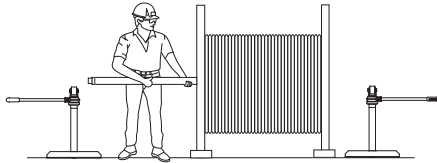
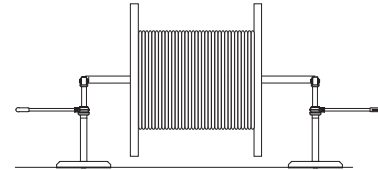

**Figure 1**

5. Turn the Reel Stand handle clockwise to extend one Reel Stand until the cable reel clears the ground. (Fig. 2)

*Note: The 656 requires the handle to be fully threaded into the handle ratchet assembly and the ratchet pawl to be set so the clicking is evident when the handle is turned counterclockwise.*

6. Turn the other Reel Stand handle until the spindle is level and the cable reel rotates freely. (Fig. 4)



**Figure 4**

4. Position Reel Stands under each end of the spindle so the Reel Stand rollers are aligned within and in contact with the spindle grooves. (Fig. 2)

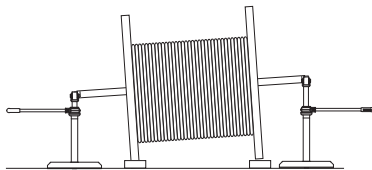

**Figure 2**

7. When finished dispensing cable, the Cable Reel should be lowered in the reverse manner as described above.

*Note: The 687 and 683 Reel Stands may require use of the quick extend feature. Manually lift the telescoping Square tubing to desired height and use the pin provided by inserting through both sides of the square tubing. The pin must rest on top of the base to prevent downward movement. (Fig. 3)*

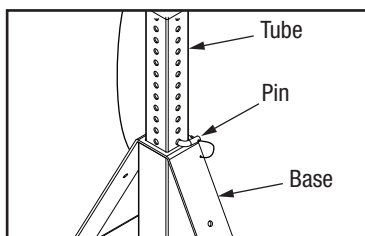

**Figure 3**



**GREENLEE®**

A Textron Company

USA	800-435-0786	Fax: 800-451-2632
	815-397-7070	Fax: 815-397-1865
Canada	800-435-0786	Fax: 800-524-2853
International	+1-815-397-7070	Fax: +1-815-397-9247

4455 Boeing Drive • Rockford, IL 61109-2988 • USA • 815-397-7070  
An ISO 9001 Company • Greenlee Textron Inc. is a subsidiary of Textron Inc.

[www.greenlee.com](http://www.greenlee.com)

Printed in USA