

Hinged-Cover Type 1 Boxes and Enclosures and Accessories

Large, Type 1



Industry Standards

UL 50, 50E Listed; Type 1; File No. E27567
 cUL Listed per CSA C22.2 No 40; Type 1; File No. E27567

NEMA/EEMAC Type 1
 CSA, File 42184: Type 1
 IEC 60529, IP30

Application

These enclosures have a size range of 42 x 30 x 9-in. to 48 x 36 x 17-in. and meet basic functionality requirements for applications that do not require oil- or dust-tight enclosures.

Features

- Continuous hinge on door
- Slotted flush latch; optional latches available
- Collar studs provided for mounting optional panels
- Mounting holes on back of enclosure; optional mounting bracket kit is available (AMFLN1)

Specifications

- 14 gauge steel

Finish

ANSI 61 gray polyester powder paint finish inside and out over pretreated surfaces. Optional panels are white.

Accessories

See also Accessories.

- T-Handle Latch and Keyed Cylinder Lock Kits
- Electric Heater
- Electrical Interlocks
- Grounding Device
- Panels for Medium Type 1 Enclosures
- Junction Box and Wall-Mount Enclosure Swing Out Panel Kit
- T-Handle Latch and Keyed Cylinder Lock Kits
- Terminal Block Kit Assembly for Junction Boxes Overview
- Touch-Up Paint
- Steel and Stainless Steel Window Kits

Bulletin: ATL

Standard Product

Catalog Number	AxBxC in./mm	Panel	Panel Size D x E in./mm	Mounting Bracket Kit
A42N3009	42.00 x 30.00 x 9.25	A42P30	39.00 x 27.00	AMFLN1
	1067 x 762 x 235		991 x 686	
A42N3609	42.00 x 36.00 x 9.25	A42P36	39.00 x 33.00	AMFLN1
	1067 x 914 x 235		991 x 838	
A48N3609	48.00 x 36.00 x 9.25	A48P36	45.00 x 33.00	AMFLN1
	1219 x 914 x 235		1143 x 838	
A48N3611	48.00 x 36.00 x 11.25	A48P36	45.00 x 33.00	AMFLN1
	1219 x 914 x 286		1143 x 838	
A42N3013	42.00 x 30.00 x 13.25	A42P30	39.00 x 27.00	AMFLN1
	1067 x 762 x 337		991 x 686	
A42N3613	42.00 x 36.00 x 13.25	A42P36	39.00 x 33.00	AMFLN1
	1067 x 914 x 337		991 x 838	
A48N3613	48.00 x 36.00 x 13.25	A48P36	45.00 x 33.00	AMFLN1
	1219 x 914 x 337		1143 x 838	
A48N3617	48.00 x 36.00 x 17.25	A48P36	45.00 x 33.00	AMFLN1
	1219 x 914 x 438		1143 x 838	

Purchase panels separately. Optional aluminum panels are available for most sizes. Mounting Bracket Kit must be ordered separately.

Hinged-Cover Type 1 Boxes and Enclosures and Accessories

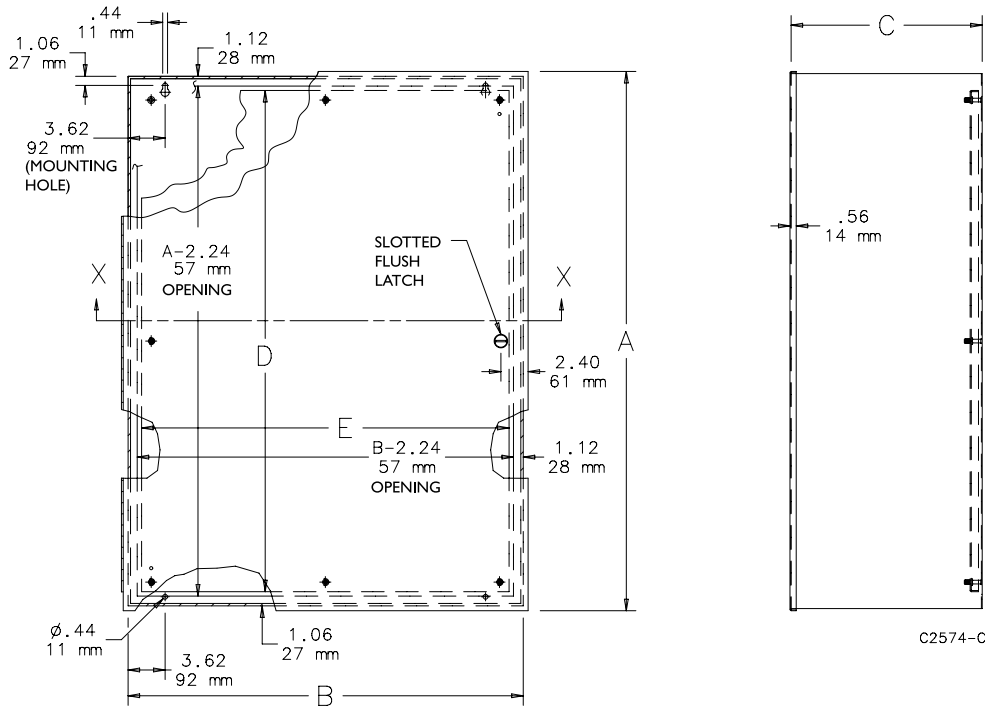

C2574-C

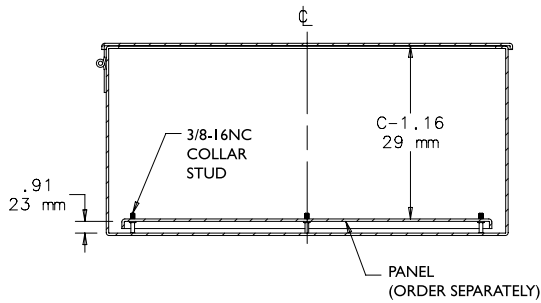

SECTION X-X

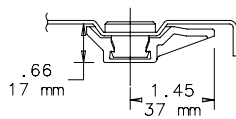
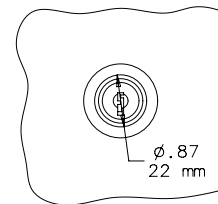
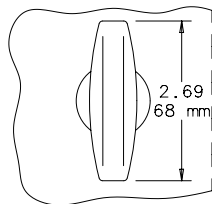
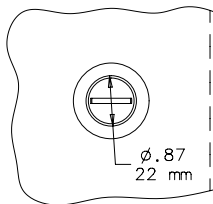

Standard Slotted
Flush Latch

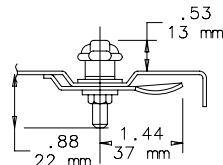

"T" Handle Latch Kit
AL7A (optional)

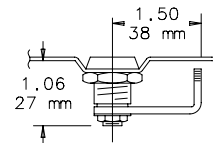

Cylinder Lock Kit
AL12AR (optional)