

SNP-3120/3120V/3120VH



4CIF 12x Network PTZ Dome Camera



SNP-3120

SNP-3120V

SNP-3120VH



Key Features

- Max. 30(25)fps at 4CIF resolution
- 3.69 ~ 44.32mm (12x) optical zoom, 16x digital zoom
- H.264, MPEG-4, MJPEG multiple codec
- PoE plus, SD memory, bi-directional audio support

Accessories (Optional)

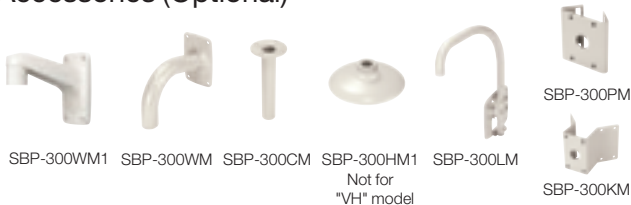

Dimensions

Unit : mm (inch)

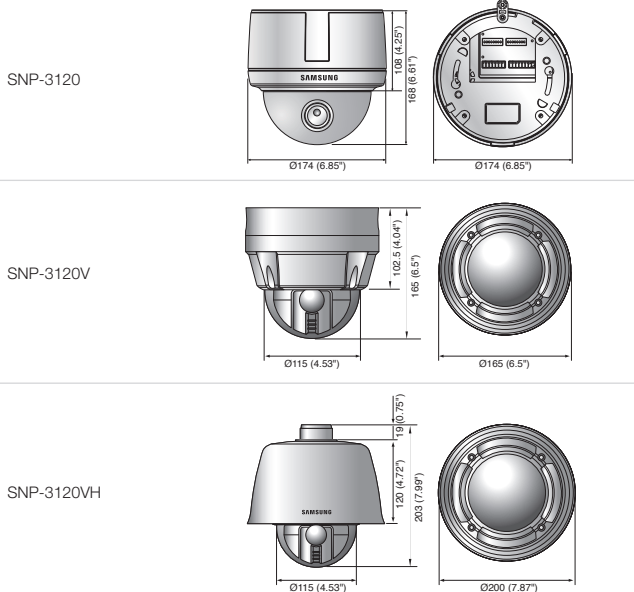

Technical Specifications

	SNP-3120N/VN/VHN	SNP-3120P/VP/VHP
VIDEO		
Imaging Device	1/4" Ex-view HAD PS CCD	
Total Pixels	811(H) x 508(V)	795(H) x 596(V)
Effective Pixels	768(H) x 494(V)	752(H) x 582(V)
Scanning System	Progressive (VPS on) (If WDR on, Interlaced scan)	
Frequency	H : 15.734KHz / V : 59.94Hz	H : 15.625KHz / V : 50Hz
Horizontal Resolution	Color : 600TV lines	
Min. Illumination	Color : 0.7Lux (F1.65, 50IRE), 0.001Lux (Sens-up 512x), B/W : 0.07Lux (F1.65, 50IRE), 0.0001Lux (Sens-up 512x)	
S / N Ratio	50dB	
Video Output	CVBS : 1.0 Vp-p / 75Ω composite	
LENS		
Focal Length (Zoom Ratio)	3.69 ~ 44.32mm (12x)	
Max. Aperture Ratio	F1.65(Wide) / F2.01(Tele)	
Angular Field of View	H : 54.44°(Wide) ~ 4.62°(Tele), V : 41.42°(Wide) ~ 3.52°(Tele)	
Min. Object Distance	0.2m(Wide) / 0.8m(Tele)	
Focus Control	AF / One-shot AF / Manual	
Lens Type	DC auto iris	
PAN / TILT / ROTATE		
Pan Range	360° Endless	
Pan Speed	Preset : 650°/sec, Manual : 0.05°/sec ~ 120°/sec (Turbo : 200°/sec)	
Tilt Range	-5° ~ 185°	
Tilt Speed	Preset : 650°/sec, Manual : 0.05°/sec ~ 120°/sec	
Preset	255ea	
Preset Accuracy	±0.1°	
OPERATIONAL		
Camera Title	Off / On (Displayed up to 12 characters)	
Day & Night	Auto (ICR) / Color / B/W	
Backlight Compensation	Off / BLC / WDR	
Wide Dynamic Range	128x, 52dB	160x, 52dB
Contrast Enhancement	XDR (eXtended Dynamic Range) (Off / Low / Medium / High)	
Digital Noise Reduction	Motion adaptive 2D+3D noise filter (Off / Low / Medium / High)	
Digital Image Stabilization	Off / On	
Motion Detection	Off / On (4 programmable zones)	
Privacy Masking	Off / On (12 polygonal programmable zones)	
Sens-up (Frame Integration)	Off / Auto (2x ~ 512x)	
Gain Control	Off / Low / Medium / High / Manual	
White Balance	ATW (In) / ATW (Out) / AWC / Manual	
Electronic Shutter Speed	Off / A.FLK / Manual (1/120 ~ 1/10Ksec)	
Digital Zoom	16x	
Flip / Mirror	Digital flip	
VPS	Off / On	
Intelligent Video Analytics	Moved / Fixed	
Alarm I/O	Input 2ea / Output 2ea (Relay)	
Remote Control Interface	RS-485	
RS-485 Protocol	Samsung-T/E, Pelco-P/D, Panasonic, Honeywell, AD, Vicon, GE, Bosch	
NETWORK		
Ethernet	RJ-45 (10/100BASE-T)	
Video Compression Format	H.264, MPEG-4, MJPEG	
Resolution	704 x 480, 640 x 480, 352 x 240, 320 x 240	704 x 576, 640 x 480, 352 x 288, 320 x 240
Max. Framerate	30fps	25fps
Video Quality Adjustment	H.264, MPEG-4 : Compression level, Target bitrate level control MJPEG : Quality level control	
Bitrate Control Method	H.264, MPEG-4 : CBR or VBR, MJPEG : VBR	
Streaming Capability	Multiple streaming (Up to 10 profiles)	
Audio I/O	Mic / Line in, Line out	
Audio Compression Format	G.711 u-law	
Audio Communication	Bi-directional audio	
IP	IPv4, IPv6	
Protocol	TCP/IP, UDP/IP, RTP(UDP), RTSP, NTP, HTTP, HTTPS, SSL, DHCP, PPPoE FTP, SMTP, ICMP, IGMP, SNMPv1/v2c/v3(MIB-2), ARP, DNS, DDNS, ONVIF	
Security	HTTPS(SSL) Login authentication, Digest login authentication IP address filtering, User access log	
Streaming Method	Unicast / Multicast	
Max. User Access	10 users at unicast mode	
Memory Slot	SD/SDHC memory slot	
ONVIF Conformance	Yes	
Web Viewer	Supported OS : Windows XP / VISTA / 7, MAC OS Supported Browser : Internet Explorer 6.0 or Higher, Firefox, Google Chrome, Apple Safari	
Central Management Software	NET-1 viewer	
ENVIRONMENTAL		
Operating Temperature / Humidity	SNP-3120 : -10°C ~ +50°C (+14°F ~ +122°F) / 20% ~ 80% RH SNP-3120V/3120VH : -50°C ~ +50°C (-58°F ~ +122°F) / Less than 90% RH	
Ingress Protection	IP66 (SNP-3120V/3120VH) * SNP-3120 not available	
ELECTRICAL		
Input Voltage	24V AC, PoE+ (IEEE802.3at)	
Power Consumption	SNP-3120 : Max. 15W, SNP-3120V/3120VH : Max. 15W (Heater off), Max. 45W (Heater on) * Heater works at AC power input only	
MECHANICAL		
Color / Material	SNP-3120 : Ivory / Plastic, SNP-3120V : Ivory / Aluminum (Vandal-resistance) SNP-3120VH : Ivory / Aluminum (Vandal-resistance), Sun-shield built-in	
Dimensions (WxH)	SNP-3120 : Ø174.0 x 168.0mm (Ø6.85" x 6.61"), SNP-3120V : Ø165.0 x 165.0mm (Ø6.5" x 6.5") SNP-3120VH : Ø200.0 x 203.0mm (Ø7.87" x 7.99")	
Weight	SNP-3120 : 1.2Kg (2.65 lb), SNP-3120V : 1.9Kg (4.19 lb), SNP-3120VH : 2.4Kg (5.29 lb)	