

Middle Atlantic Products

EXCEPTIONAL SUPPORT & PROTECTION™

EIA/TIA Compliant

Sliding Shelves

Features

SS Features

- All steel construction
 - Latches in closed and open position
 - Full extension ball bearing slides extend 14"
 - Telescopic rear supports fit all cabinets
 - Shelf area 17-1/2" wide by 14-5/8" deep
 - UL listed in the US and Canada
- * Note: This shelf occupies slightly more than one rackspace



SS

SSL Features

- Nylon roller slides extend 11-3/8"
- Occupies one rackspace
- Telescopic rear support mounts to any rack (rear rackrail required in steel racks)
- Made with an attractive black laminate material
- Shelf area 16" wide by 13-3/4" deep
- UL listed in the US and Canada



SSL

Architects' and Engineers' Specifications

SS

EIA/TIA compliant sliding shelf shall be Middle Atlantic Products model # SS. SS shall be constructed of the following materials: shelf and rear mounting brackets shall be 16-gauge steel. Full-extension, ball-bearing slides shall extend 14". Shelf area shall be 17.5" W x 14.69" D. Heavy-duty quarter-turn, detented latch shall keep the shelf in its open or closed position. Maximum weight capacity shall be 50 lbs. SS shall be UL Listed in the US and Canada. Sliding shelf shall be GREENGUARD Indoor Air Quality Certified for Children and Schools. Sliding shelf shall be RoHS EU Directive 2002/95/EC compliant. Sliding shelf shall be manufactured by an ISO 9001 and ISO 14001 registered company. Sliding shelf shall be warranted to be free from defects in material or workmanship under normal use and conditions for a period of three years.

SSL

EIA/TIA compliant low profile sliding shelf shall be Middle Atlantic Products model # SSL. SSL shall be constructed of the following materials: shelf shall be made with an attractive black laminate material and rear-mounting brackets shall be 16-gauge steel. Full-extension, nylon roller slides shall extend 10". Shelf area shall be 16" W x 13-3/4" D. Maximum weight capacity shall be 35 lbs. SSL shall be UL Listed in the US and Canada. Low profile sliding shelf shall be GREENGUARD Indoor Air Quality Certified for Children and Schools. Low profile sliding shelf shall be RoHS EU Directive 2002/95/EC compliant. Low profile sliding shelf shall be manufactured by an ISO 9001 and ISO 14001 registered company. Low profile sliding shelf shall be warranted to be free from defects in material or workmanship under normal use and conditions for a period of three years.

CUSTOMIZABLE SPECIFICATION CLIPS AVAILABLE AT MIDDLEATLANTIC.COM

Sliding Shelves basic dimensions



SS Sliding Shelf

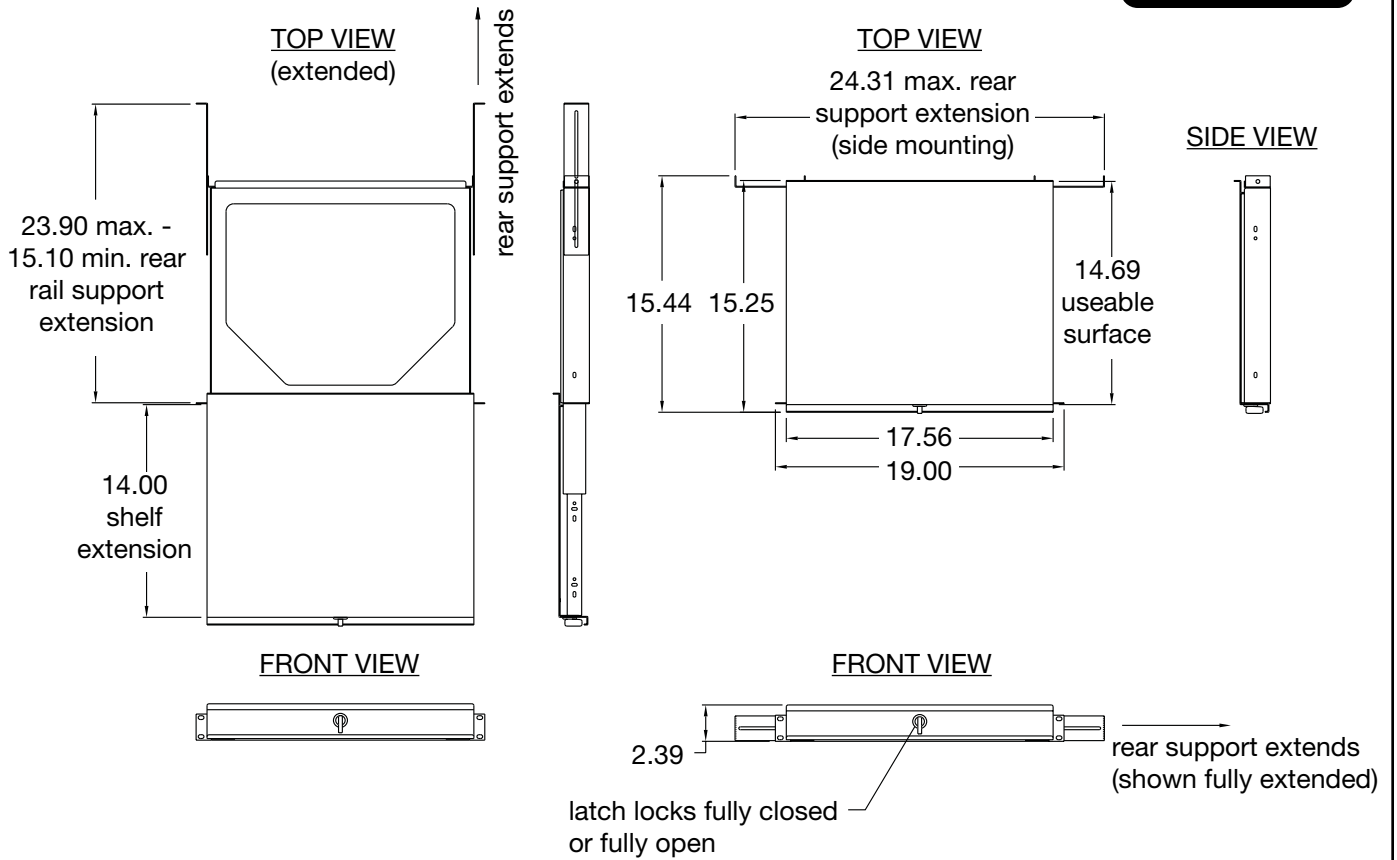

SSL Sliding Shelf

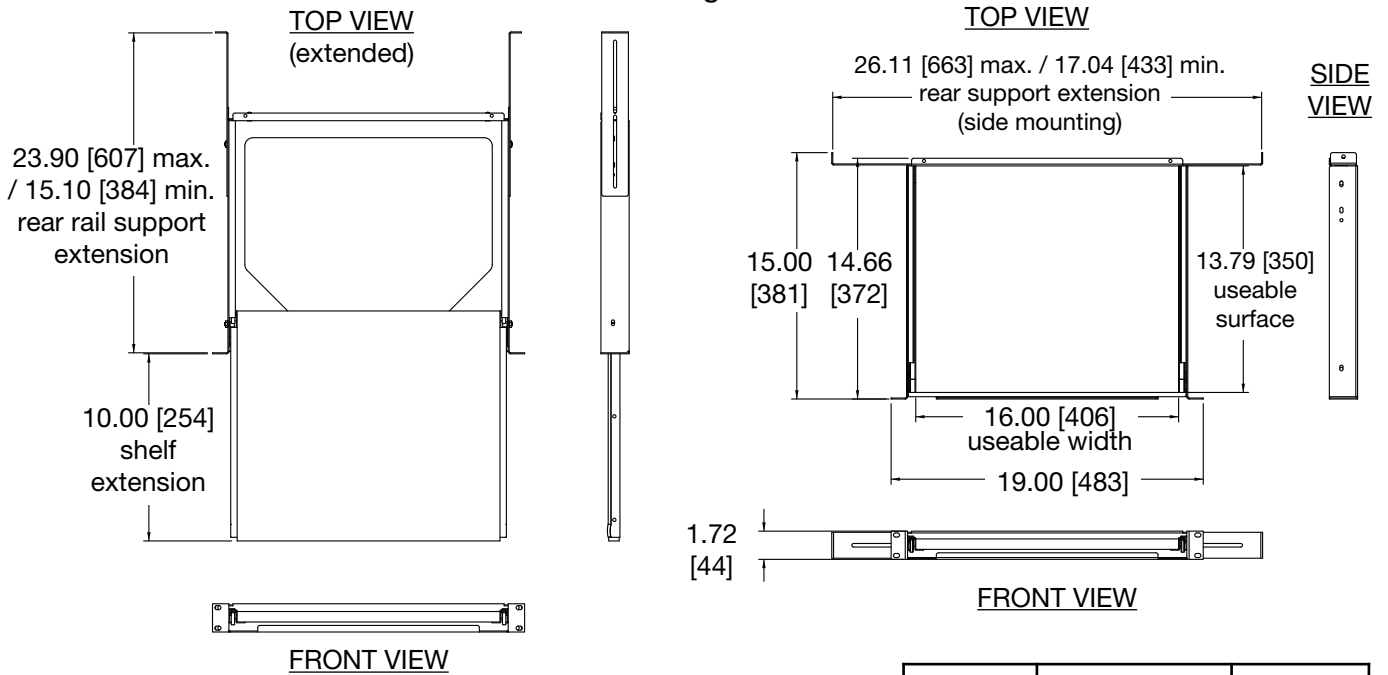

Part #	Useable Shelf Area	Weight Capacity
SS	17.56" W x 14.75" D	50 lbs.
SSL	16" W x 13.79" D	35 lbs.