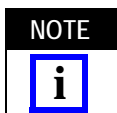

Figure 1

## 1. INTRODUCTION

Splice Tray Assembly 559433-3 is used to protect and manage ribbon, discrete (with outside diameter of 3 mm [.12 in.], or multi-fiber (with outside diameter greater than 3 mm [.12 in.] jacketed fiber optic cable with mechanical splices, sleeved fusion splices, splitters and couplers, and other passive devices. These trays accommodate butt cable splicing.

Read these instructions thoroughly before starting installation or fiber routing.



*Dimensions in this instruction sheet are in millimeters [with inches in brackets]. Figures are not drawn to scale.*

## 2. DESCRIPTION (Figure 1)

The fiber is held in place by end caps located at one end of the tray or, for multi-fiber cable, by using cable ties in tie-down holes along the sides of the tray next to the end caps. Each end cap has a removable cover used to secure the fiber.

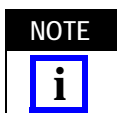

*End cap covers are included for discrete fiber installation and ribbon fiber installation.*

After splicing, the fiber is routed to the holder (UDH or ESH), and the splice placed in the center of the holder. The holder is positioned in the tray according to the application and provides positive retention for the fibers. Excess fiber is coiled in the tray and held in place by the fiber routing tab.

The tray has a clear removable cover with retention tabs which butt against the latches on the tray to hold the cover in place. The latches also help align the trays when stacked.

## 3. INSTALLATION

Use the following guidelines when installing and routing the fiber in the tray. Whatever method is used, make sure that it not only meets the application needs, but also conforms to local codes and standards.

- Allow enough fiber in the tray for the service loop and fiber routing
- Coil excess fiber in the tray
- Keep bend radii of fiber as large as possible (always follow manufacturer's minimum bend radius)

### 3.1. Preparation



**ALWAYS** wear eye protection when working with optical fibers. **NEVER** look into the end of a terminated or unterminated fiber. Laser radiation is invisible but can damage eye tissue. **NEVER** eat, drink, or smoke when working with fibers. This could lead to ingestion of fiber particles.



**BE VERY CAREFUL** to dispose of fiber ends properly. The fibers create slivers that can easily puncture the skin and cause irritation.

1. Slightly lift one of the retention tabs on the cover. While lifting the tab, slide the cover toward the latch, and remove the cover from the tray. See Figure 2.
2. Remove the end cap covers from the end caps. Lift the inside edge of the end cap cover, and roll the cover to the outside edge. See Figure 3.



The end caps are not used for routing multi-fiber cable, therefore it is not necessary to remove the end cap covers if using multi-fiber cable.

*Removing End Cap Covers  
(Covers for Ribbon Fiber Shown)*

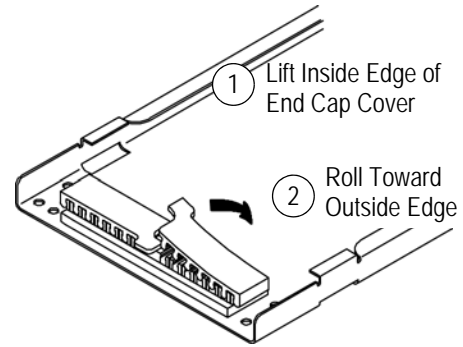

Figure 3

3. Remove the backing from the foam tape on the underside of the holder. Position the holder in the tray at an angle and so that it conforms to the dimensions shown in Figure 4.

*Removing Tray Cover*

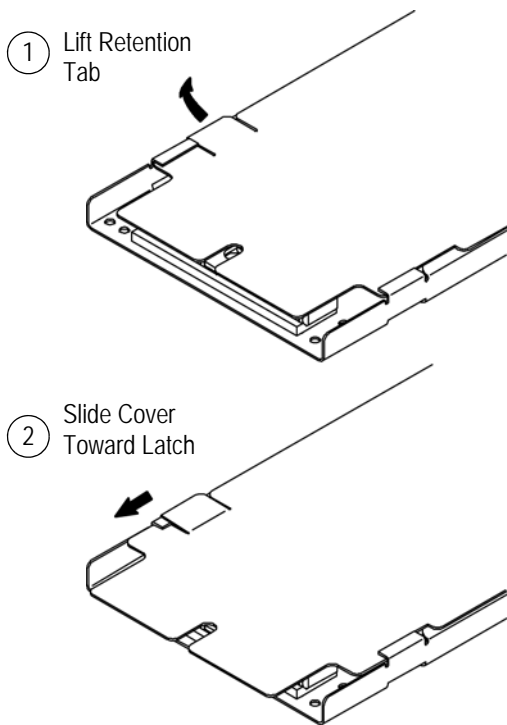

Figure 2

*Installing Holder*

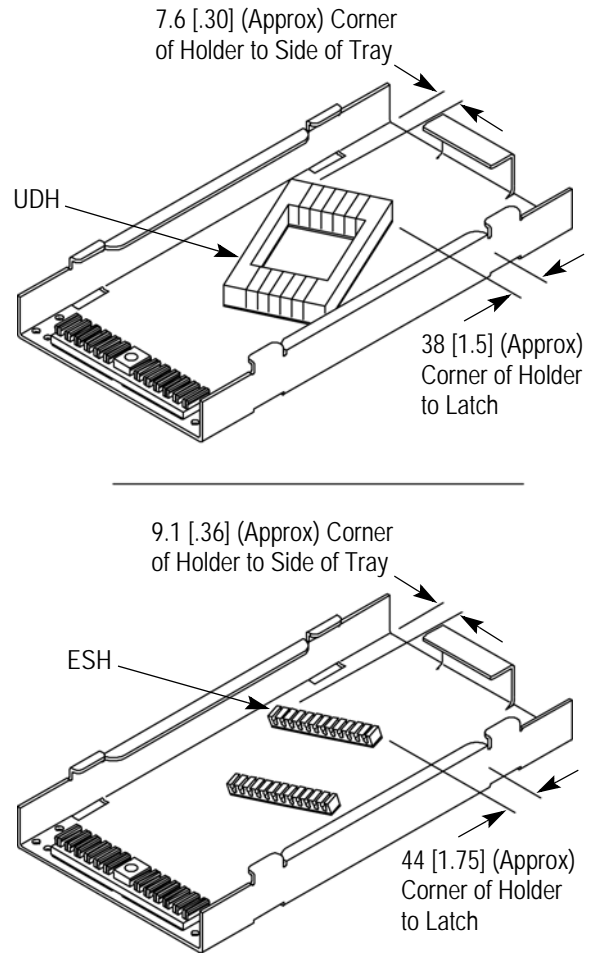

Figure 4



The following illustrations depict installing ribbon fiber and the UDH, however discrete fiber and/or the ESH would be installed in the same manner.

### 3.2. Routing Ribbon Fiber

1. Measure approximately 610 [24] of incoming fiber, and fit the fiber into the first slit (slit closest to the side of the tray) in either end cap. Refer to Figure 5, Detail A.
2. Loop the incoming fiber around the holder and under the fiber routing tab. Temporarily fit the fiber into the first (outermost) slit in the holder as shown in Figure 5, Detail A.
3. Measure approximately 330 [13] of outgoing fiber, and fit the fiber into the first slit (slit closest to the side of the tray) in the opposite end cap. Refer to Figure 5, Detail B.
4. Loop the outgoing fiber around the holder and under the fiber routing tab, and temporarily fit the fiber into the first (outermost) slit in the opposite end of the holder as shown in Figure 5, Detail B.



When routing the fiber, make sure to keep the outgoing fiber between the incoming fiber loops to prevent fiber cross-over.

5. Remove both fibers from the holder, and splice them according to local practices. Be careful not to twist the fibers. Fit the fibers back into the slits with the splice positioned in the cutout in the holder. See Figure 5, Detail B.
6. Repeat these steps for a maximum of six splices (for UDH) and twelve splices (for ESH)- working from the outside to the center of the tray. See Figure 5, Detail C for a properly loaded tray.

### 3.3. Routing Discrete Fiber (Outside Diameter of 3 [.12])

1. Remove approximately 457 [18] of the outer jacket from the incoming fiber, and fit the fiber into the first slit (slit closest to the side of the tray) in either end cap. Refer to Figure 6.
2. Carefully loop the slack of the incoming fiber around the holder and under the fiber routing tab.
3. Remove approximately 457 [18] of the outer jacket of the outgoing fiber, and fit the fiber into the first slit (slit closest to the side of the tray) in the opposite end cap. See Figure 6.
4. Carefully loop the slack of the outgoing fiber around the holder and under the fiber routing tab.
5. Splice the fibers according to local practices. Fit the incoming fiber into the first (outermost) slit in the holder, and fit the outgoing fiber into the first (outermost) slit in the opposite end of the holder. Position the splice in the cutout in the holder. See Figure 6.

#### Routing Ribbon Fiber

Detail A

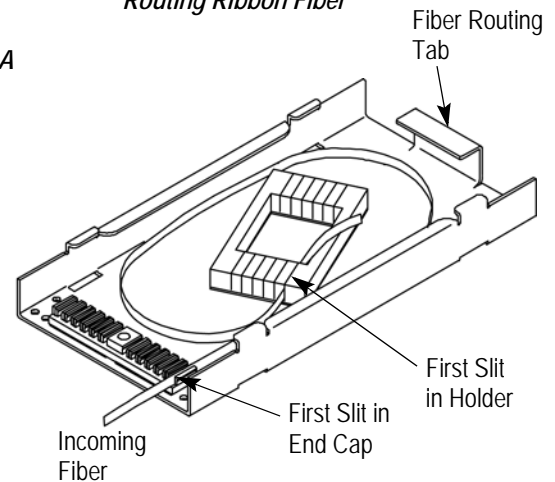

Detail B

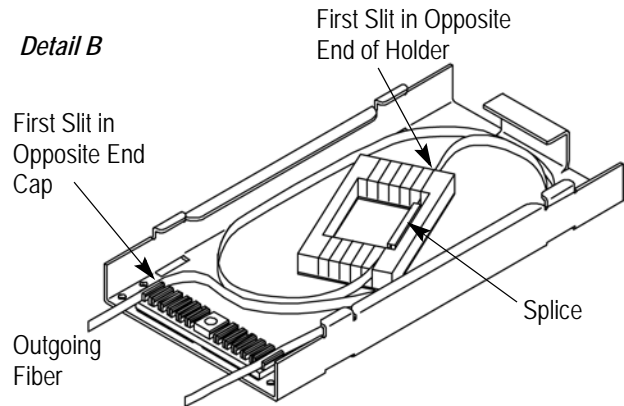

Detail C

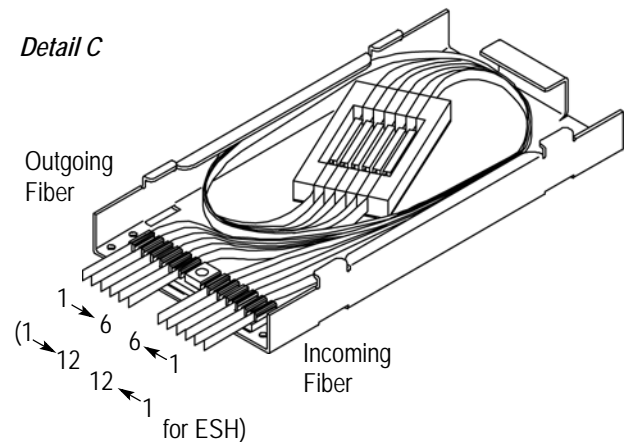
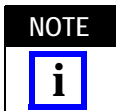

Figure 5

6. Repeat these steps for a maximum of six splices (for UDH) and twelve splices (for ESH)- working from the outside to the center of the tray.



Only one holder can be used per tray.

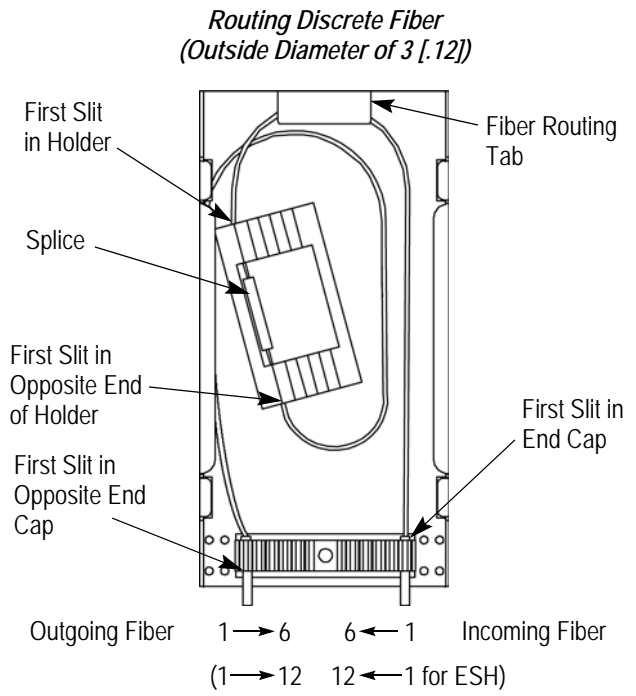

Figure 6

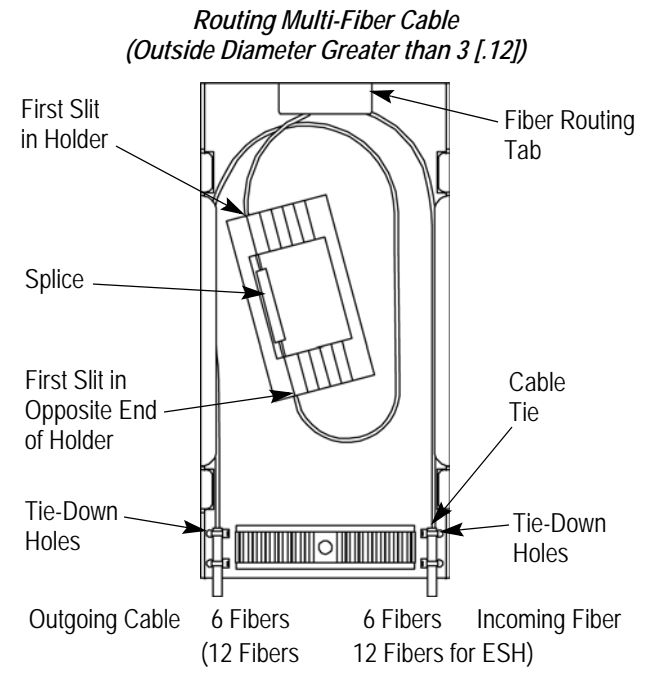

Figure 7

### 3.4. Routing Multi-Fiber Cable (Outside Diameter Greater Than 3 [.12])

1. Remove approximately 457 [18] of the outer jacket from the incoming cable. Position the cable in the tray so that the jacket is over the tie-down holes on one side of the tray. Secure the cable with cable ties.

**CAUTION** Do NOT over-tighten cable ties when securing cable.

2. Carefully loop the slack of the incoming fiber around the holder and under the fiber routing tab.

3. Remove approximately 457 [18] of the outer jacket from the outgoing cable. Position the cable in the tray so that the jacket is over the tie-down holes on the opposite side of the tray. Secure the cable with cable ties.

**CAUTION** Do NOT over-tighten cable ties when securing cable.

4. Carefully loop the slack of the outgoing fiber around the holder and under the fiber routing tab.

5. Splice the fibers according to local practices.

6. Fit the incoming fiber into the first (outermost) slit in the holder, and fit the outgoing fiber into the first (outermost) slit in the opposite end of the holder. Position the splice in the cutout of the holder. See Figure 7.

7. Repeat these steps for a maximum of six splices (for UDH) and twelve splices (for ESH)- working from the outside to the center of the holder.

**NOTE** Only one holder can be used per tray.

### 3.5. Closing the Tray

1. Install the appropriate end cap covers onto the end caps. Position the end of the cover (tab end if using cover for ribbon fiber) over the center of the end cap, then press and roll the cover over each fiber. See Figure 8.

#### Installing End Cap Covers (Composite Illustration)

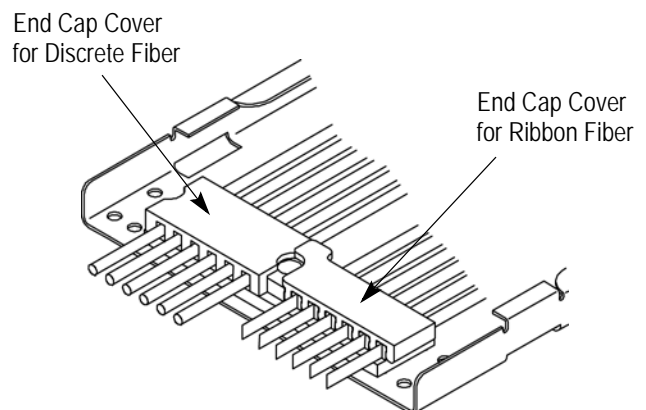

Figure 8

---

2. Lay the tray cover on top of the tray. Position the cover so that the short tabs are in front of the tray latches and one retention tab is on top of one latch. Press the short tabs down at that end, and slide the cover toward the opposite end. Listen for the audible “click” to ensure proper installation.

#### 4. ORDERING INFORMATION

The trays and components are not repairable if damaged. Additional holders can be ordered for the trays. Order additional trays and components, and holders through your representative, or call 1-800-526-5142, or send a facsimile of your purchase order to 717-986-7605, or write to:

CUSTOMER SERVICE (038-035)  
TYCO ELECTRONICS CORPORATION  
PO BOX 3608  
HARRISBURG PA 17105-3608

#### 5. REVISION SUMMARY

Since the previous version of this document, the following changes were made:

- Updated document to corporate requirements.