

Figure 1

1. INTRODUCTION

The low-profile floor fitting kits shown in Figure 1 are used to house SL 110Connect Modular Jack Kits 558054-1 (Category 5e) and 1933377-1 (Category 6). The modular jack kits include a bracket for mounting the modular jack. Modular Jack Bracket Assembly 1499543-1 is also available separately.

Reasons for reissue of this instruction sheet are provided in Section 4, REVISION SUMMARY.

2. DESCRIPTION

Each floor fitting kit consists of a base, a cover, and attaching screws. The cover features breakout tabs to accommodate the modular jacks. The mounting plate can be attached to the floor using the adhesive-backed foam tape or customer-supplied screws and outlet anchors.

3. INSTALLATION

- Center the mounting plate on a chalk line using the center indicator marks. Secure the mounting plate to the floor using the foam tape—or if using mounting hardware, use the mounting plate as a template to mark the mounting hole locations. Prepare the surface (drill holes and vacuum debris); then, install the hardware. See Figure 2.

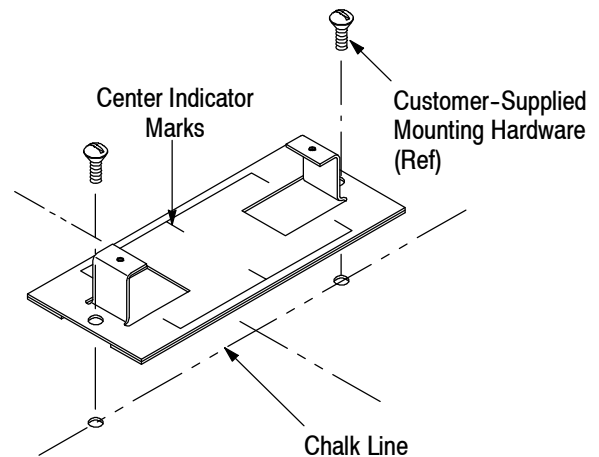

Figure 2

NOTE

Figures are not drawn to scale.



- Install the undercarpet twisted-pair cable according to Instruction Sheet 408-3194.

AMP NETCONNECT logo is a trademark of Tyco Electronics.

3. Center the modular jack bracket over the scribe lines of the mounting plate, then secure it using the adhesive-backed foam tape (provided with the bracket). See Figure 3.

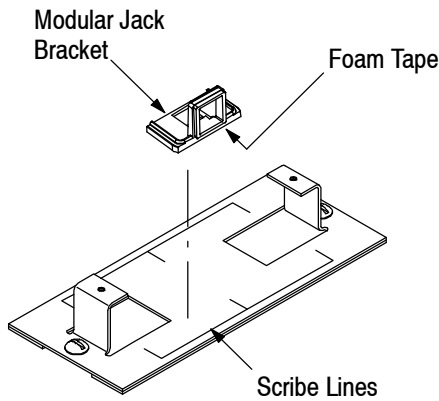

Figure 3

4. Terminate the undercarpet twisted-pair cable to the modular jack according to the instructions included with the modular jack.

5. Insert the modular jack into the bracket with the movable latch facing the base of the bracket until it is secure. See Figure 4.

6. Install Undercarpet Hold-Down Tape 553481-1 to secure the cable to the floor. Refer to Figure 4.

7. Remove the break-out tab(s) corresponding to the modular jack(s) from the cover. Secure the cover to the mounting plate using the attaching screws. See Figure 4.

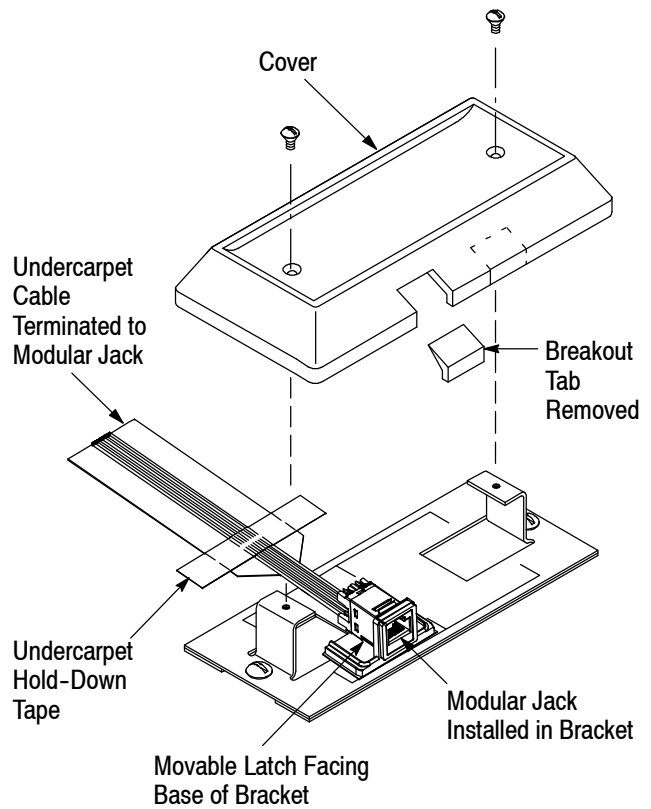

Figure 4

4. REVISION SUMMARY

Revisions to this instruction sheet include:

- Updated document to corporate requirements
- Modified title of instruction sheet
- Modified Sections 1, 2, and 3
- Modified Figures 1, 2, 3, and 4