

4-Port Module Kit Shown

KIT DASH NUMBER	MODULE COLOR
-1	Light Almond
-2	Black
-3	White
-4	Grey
1- -1	Electric Ivory

Figure 1

1. INTRODUCTION

Module Kits 1933668-[], 1933671-[] (shown in Figure 1) and 1933674-[] are designed to house and protect connections for copper and fiber optic applications. The module kits accept any combination of AMP-TWIST* modular jacks, SL series modular jacks, copper and fiber optic multi-media inserts, and LC and MT-RJ outlet jacks.

All module kits can be mounted to a flat surface; the 4- and 6-port module kits will also fit standard single- and double-gang NEMA electrical boxes and face plates having a hole spacing of 120.6 [4.75].

To obtain information on AMP NETCONNECT products, call PRODUCT INFORMATION at the number at the bottom of this page, or visit the AMP NETCONNECT website at www.ampnetconnect.com.



Refer to AMP NETCONNECT Catalog 82164 for a list of specific compatible jacks and inserts.

2. DESCRIPTION

Each module kit consists of a module base with 2 self-tapping mounting screws, a cover with a mounting screw, adhesive foam tape, an identification label and label cover, and cable ties.



All numerical values in this instruction sheet are in metric units [with U.S. customary units in brackets]. Dimensions are in millimeters [and inches]. Figures are not drawn to scale.

The module base features a through-wall cable entrance, raceway cable entrances with cable tie downs, and fiber optic cable guides to facilitate cable

AMP NETCONNECT logo is a trademark of Tyco Electronics. NEMA is a trademark of National Electrical Manufacturers Association Corporation.

management. The module base provides 3 mounting options: holes that accept the self-tapping screws, adhesive foam tape—both for mounting to a flat surface, and magnet holders that accept magnets (available separately) for mounting to a ferromagnetic surface.

The cover features embossed port identification numbers, icon holder for each port, and a label holder. The cover has break-outs on the sides and back that accommodate commercial raceways (not included).

3. MOUNT THE MODULE

3.1. Flat Surface

A. Using Foam Tape (Included with Module Kit)

1. Remove the protective adhesive paper from one side of the foam tape, and place the foam tape on the bottom of the module base. Recommended location is shown in Figure 2.

2. Remove the protective adhesive paper from the foam tape, and place the module on a flat surface. Press the module to secure the foam tape.

B. Using Self-Tapping Screws (Included with Module Kit)

1. Position the module base on the flat surface at the desired location. Mark holes on the surface using the mounting holes of the module base, then remove the module base. Refer to Figure 3.

NOTE *The 2-port module base has 2 mounting holes, and the 4- and 6-port module bases have 6 mounting holes.*

2. Drill the holes into the surface. If required, install screw mounting anchors (customer supplied).

3. Align the mounting holes of the module base with the drilled holes or mounting anchors. Install the self-tapping screws, then tighten them until the module base is flat against the surface.

C. Using Magnet 1933677-1 (Available Separately)

1. Slide a magnet under each magnet holder on the top of the module base as shown in Figure 4.

NOTE *The 2-port module base has 1 magnet holder, and the 4- and 6-port module bases have 2 magnet holders.*

2. Place the module onto a flat ferromagnetic surface.

Recommended Location of Foam Tape (Bottom of Module Base)

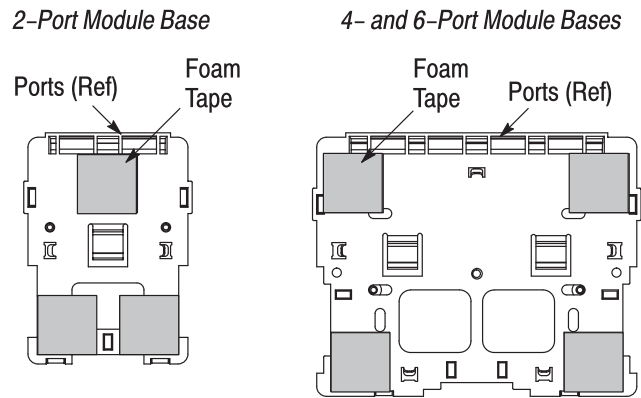

Figure 2

Self-Tapping Screws Location (Top of Module Base)

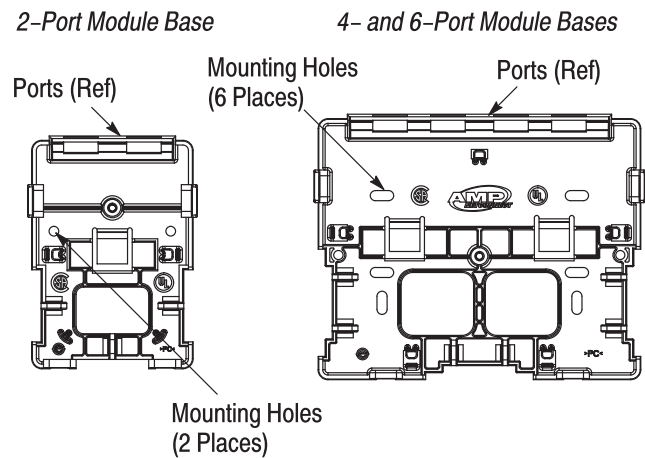

Figure 3

Magnet Location (Top of Module Base)

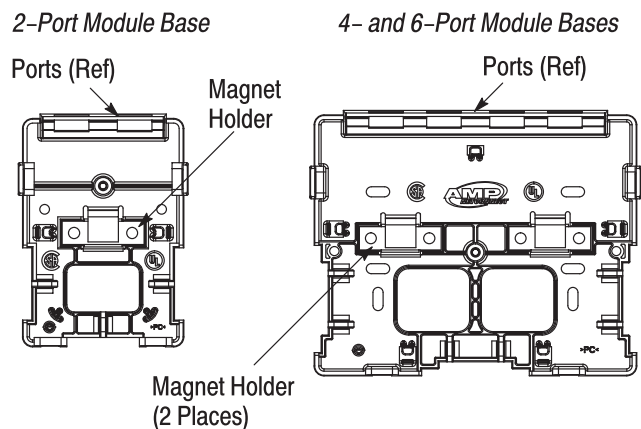

Figure 4

3.2. NEMA Electrical Box and European Mounting Base (4- and 6-Port Module Kits Only)

1. Align the module base mounting holes with the screw holes in the electrical box or mounting base.
2. Thread, then hand-tighten screws (customer supplied) until the module base is secure to the electrical box or mounting base.

4. ASSEMBLY PROCEDURE

4.1. Route the Cable and Install the Jacks and Multi-Media Inserts

1. Route the cable(s) through the through-wall cable entrance and/or raceway cable entrance of the module base (shown in Figure 1), and terminate the jacks or multi-media inserts to the cable according to the instructions packaged with the product.

For fiber optic applications, route the cable through the fiber optic cable guides.



NEVER place cable under tension or torsion. Dress cable using the minimum bend radius and maximum tensile loading as recommended in Electronic Industries Alliance (EIA) 568.

2. Coil excess cable around the inside of the module base. Retaining walls of the fiber optic guides can be deflected outward to assist in dressing the cable.
3. From the inside of the module base, align the jack or multi-media insert with the appropriate port of the modular base. Make sure that the movable latch is facing UP (away from modular base). Insert the jack or multi-media insert, at a slight angle, into the port then rotate it upwards until the movable latch snaps into place. Repeat this step for the remaining jacks or multi-media inserts. Refer to Figure 5.
4. Using the cable ties, secure the cable to the cable tie-downs.



To avoid distortion or damage to the cable, DO NOT over-tighten the cable ties.

4.2. Install the Cover

1. If using raceway(s), proceed as follows:
 - a. Use a sharp instrument to scribe the appropriate break-out(s) of the cover, then remove the break-out(s). Refer to Figure 6.
 - b. Install an appropriate-sized raceway(s) (customer supplied) onto the break-out(s) according to manufacturer recommendations.

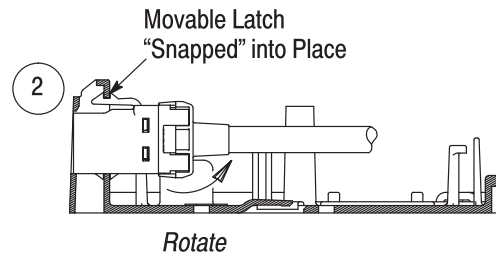
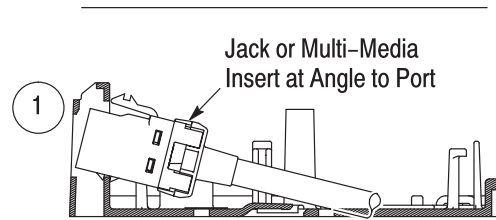
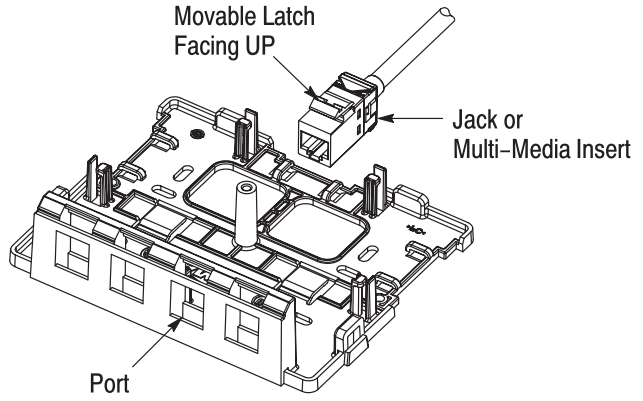

Figure 5

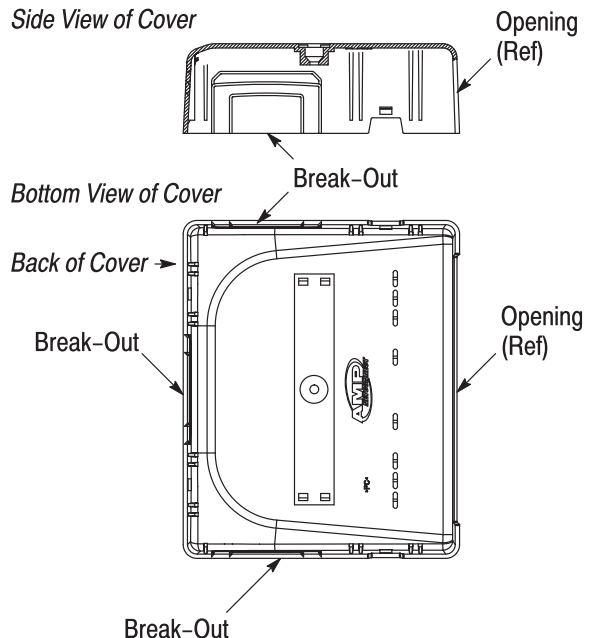

Figure 6

NEMA is a trademark of National Electrical Manufacturers Association Corporation.

2. Align the opening of the cover with the ports of the module base, and push the cover onto the module base until all of the locks engage and the bottom of the cover is against the mounting surface. See Figure 7, Detail A.

3. Thread the cover screw into the hole in the top of the cover; tighten the screw until it is snug and the head of the screw is below the surface of the label holder. See Figure 7, Detail B.

4. If desired, write on the identification label, then lay the label into the label holder, and install the cover onto the label holder.

5. If desired, install icons into the icon holders for port identification.

5. REMOVAL

5.1. Removing Cover

1. Remove the label cover and label from the label holder of the cover.

2. Remove the cover screw from the top of the cover.

3. Insert the tip of a small flat instrument into either slot located on the sides of the cover, and twist the instrument until the cover disengages. Do the same with the other slot. Then, lift the cover off of the module base.

Installing Cover

Detail A

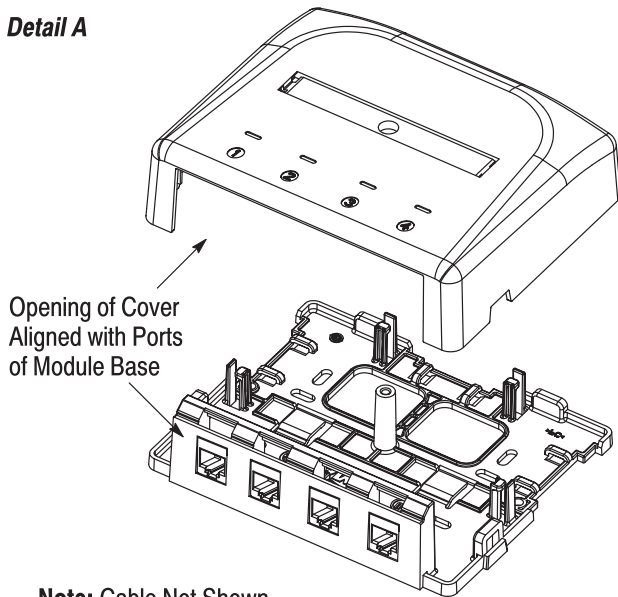

Detail B

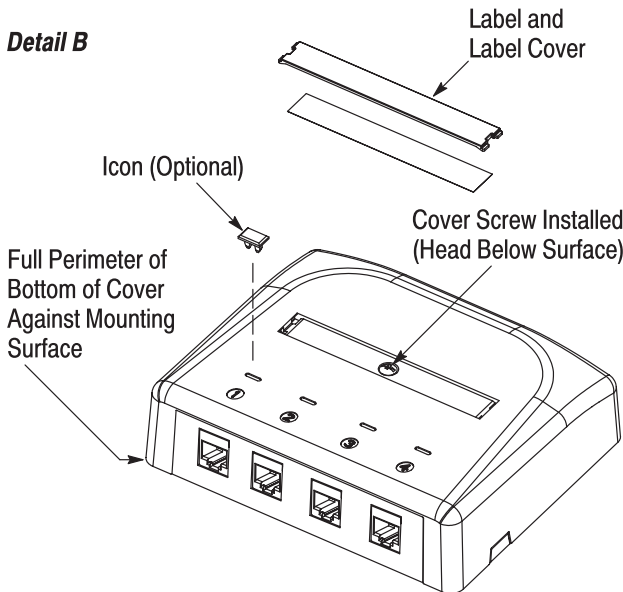

Figure 7

Removing Cover

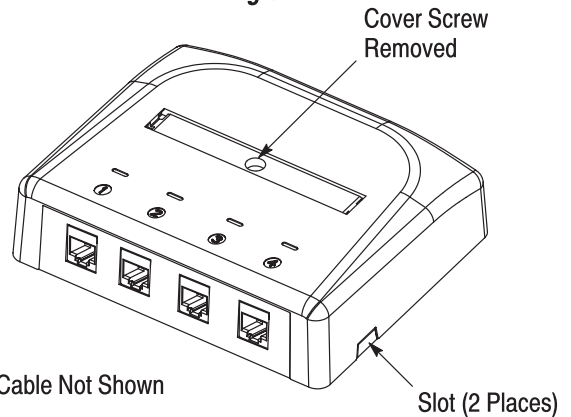

Figure 8

5.2. Removing Jack or Multimedia Insert

1. Place the tip of a small screwdriver under the movable latch of the jack or multi-media insert, then pry the tip downward slightly until the latch partially disengages.

2. Rotate the jack or multi-media insert away from the port until the latch is fully disengaged; then remove the jack or multi-media from the port.

6. REPLACEMENT

DO NOT use any defective or damaged components.

7. REVISION SUMMARY

- Initial release of instruction sheet