

NOTE

All numerical values are in metric units [with U.S. customary units in brackets]. Dimensions are in millimeters [and inches]. Unless otherwise specified, dimensions have a tolerance of ± 0.13 [.005] and angles have a tolerance of $\pm 1^\circ$.

1. INTRODUCTION

This specification covers requirements for the application of AMP* Grounding Clip Terminals with the AMP Tab-Lok wire barrel feature. This special crimp feature provides reliable electrical and mechanical performance. The characteristic feature of the crimp is a tab which is inserted through a slot in the terminal; it is crimped against the bottom of the wire barrel terminating 18-14 AWG stranded wire.

The design of this terminal virtually eliminates the need for fastening Ground Lead Terminals with screws or bolts. The clip area of the terminal attaches to a variety of painted and bare metal panels ranging in thickness from 0.48 to 1.80 [.019 to .071].

The Grounding Clip Terminal is available in stainless steel and in phosphor bronze. The pilot hole in the clip area allows you the option of installing this terminal permanently; use a No. 6 sheet metal screw.

Figure 1 shows the product and terms of its features. These terms will be used throughout this specification.

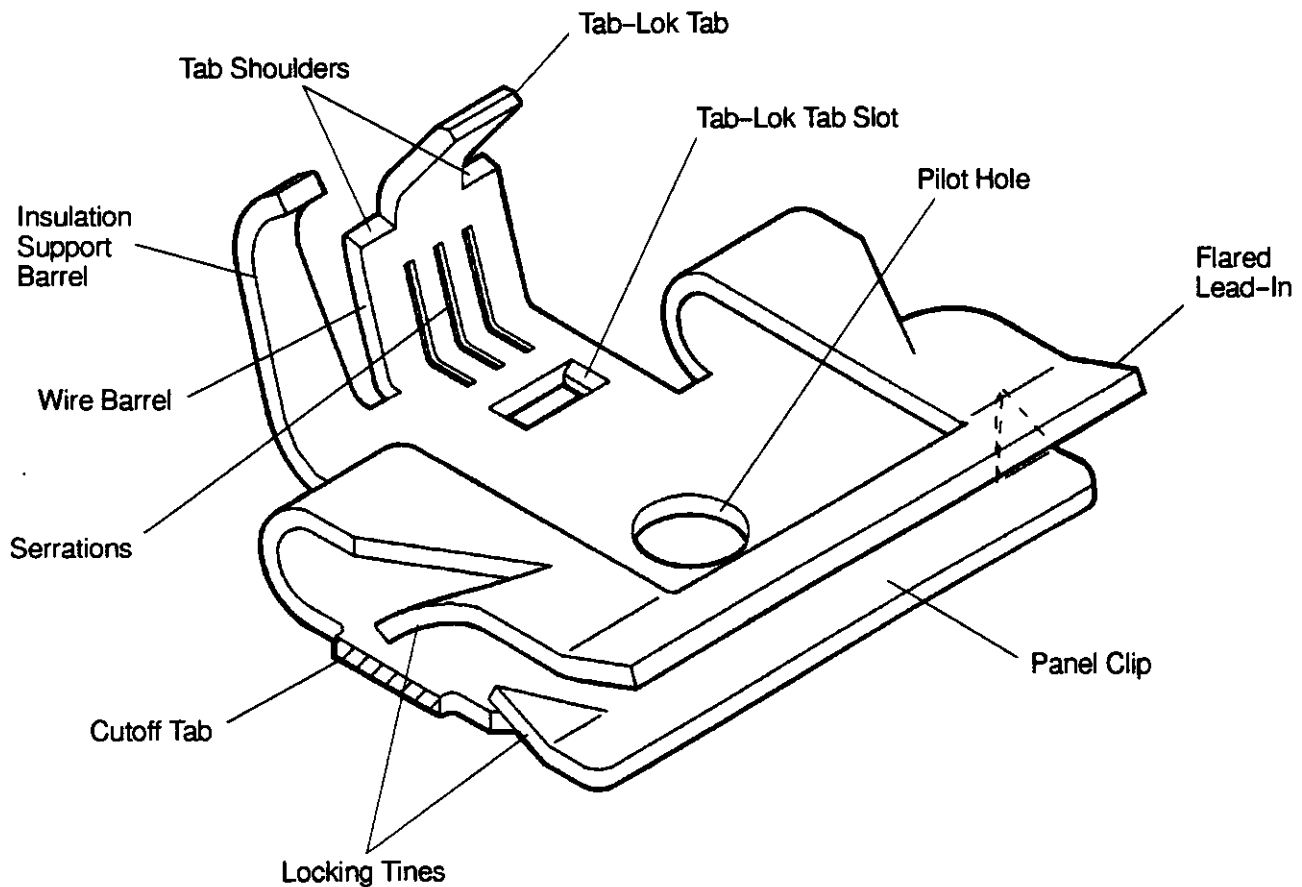
*Figure 1*

91AS-1

2. REFERENCE MATERIAL

2.1. Customer Assistance

Product Part Number 63575 and Product Code 0779 are representative of AMP Grounding Clip Terminals. Use of these numbers will identify the product line and expedite your inquiries through an AMP service network established to help you obtain product and tooling information. Such information can be obtained through a local AMP Representative (Field Sales Engineer, etc) or, after purchase, by calling the TOOLING ASSISTANCE CENTER number at the bottom of page 1.

2.2. Engineering Drawings

Customer Drawings for specified products are available from the service network. The information contained in the Customer Drawings takes priority if there is a conflict with this specification or with any other technical documentation supplied by AMP Incorporated.

2.3. Specifications

These commercial specifications cover related grounding clip requirements:

Underwriters' Laboratories, Inc. (UL)

- UL250 – Household Refrigerators and Freezers Standards for Safety
- UL560 – Electric Home Laundry Equipment Standards for Safety
- UL858 – Household Electric Ranges Standards for Safety
- UL486E – Equipment Wiring Terminals Standards for Safety

Canadian Standards Association (CSA)

- CSA C22.2 Number 0-M1982 – General Requirements – Canadian Electrical Code
- CSA C22.2 Number 41-M1987 – Grounding and Bonding Equipment

2.4. Technical Publications

These AMP Applicator Instruction Sheets (408) provide applicator tooling information:

- 408-8097 — End-Of-Wire Applicator
- 408-8101 — Center-Strip Applicator

These AMP Customer Manuals (409) provide machine application information:

- 409-5128 — AMP-O-ELECTRIC Model "K" Terminating Machine
- 409-5290 — AMPOMATOR® IV B Machine
- 409-5579 — AMP Model "T" Terminating Unit for use in automatic machines
- 409-5619 — AMPOMATOR CLS II Lead-Making Machine
- 409-5755 — AMP Split-Cycle Model "TII" Terminating Machine
- 409-5806 — AMPOMATOR CLS III Lead-Making Machine
- 409-5808 — AMP Split-Cycle Model "T" Terminating Machine
- 409-5817 — AMP Split-Cycle Model "TII" Terminating Machine with Precision Adjustment Base

3. REQUIREMENTS

3.1. Storage

To protect the grounding clips from damage or contamination, keep them in their shipping container until ready for use.

3.2. Wire Selection

This grounding clip accepts wire sizes 18–14 AWG with an insulation outside diameter of 2.54–3.56 [.100 to .140].

3.3. Wire Preparation

Wire strip length for end-of-wire termination is 5.54 ± 0.38 [.218 \pm .015].

Wire for center-strip termination needs no preparation; stripping and crimping is done by the machine in one operation.

3.4. Panel Preparation

If the grounding clip is to be installed permanently, a clearance hole must be drilled into the panel. Dimensions for placement and diameter of this hole are for reference only; they are shown in Figure 2.

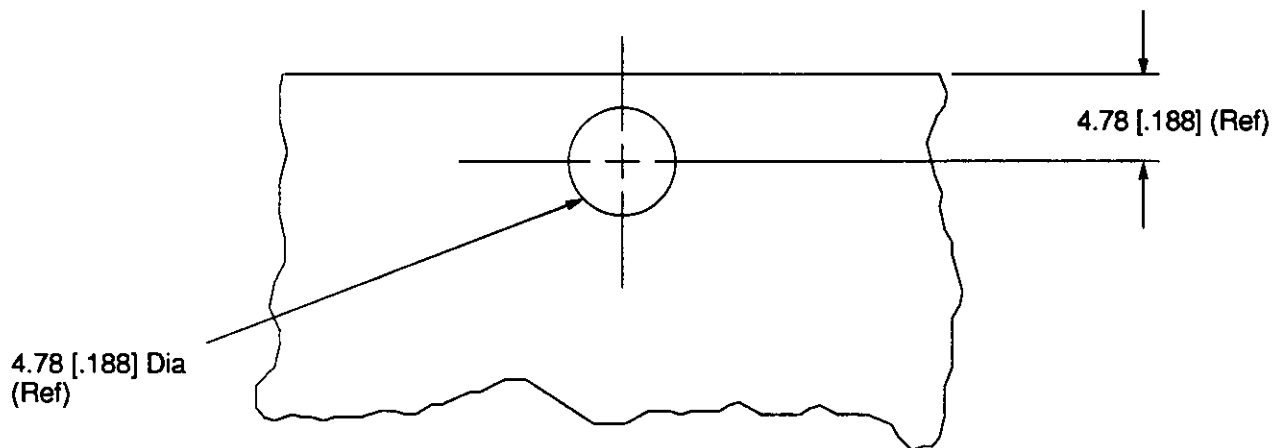

Figure 2

200-083E

3.5. Crimped Terminal Requirements (Figure 3)

Crimp grounding clip terminal according to instructions packaged with tool used.

NOTE

DO NOT cut or break wire insulation while crimping wire.

Figure 3 shows a grounding clip as it should appear after crimping.

The table in Figure 3 lists crimp dimensions arranged by base material and wire sizes.

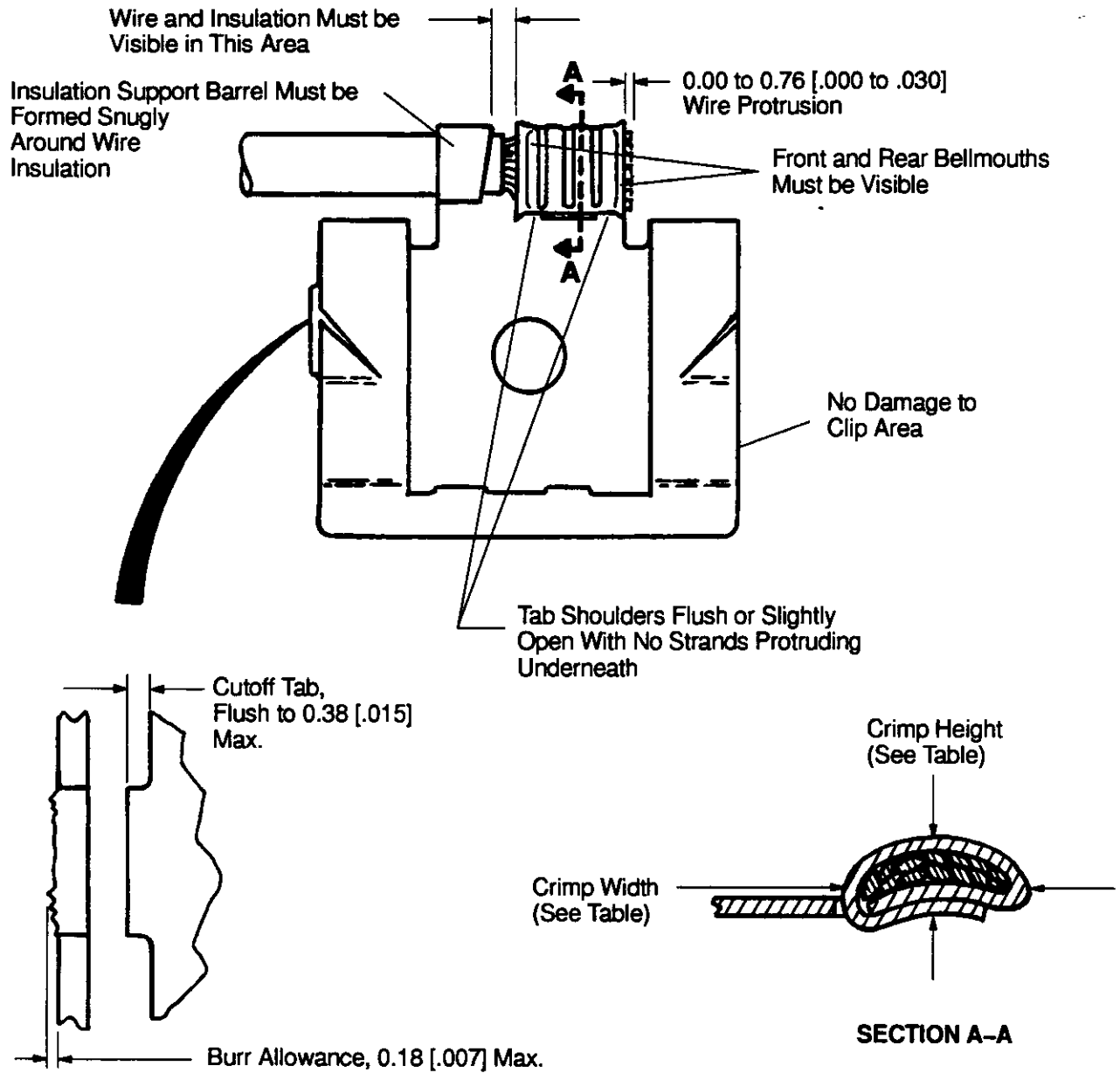

Terminal Stock Thickness	Terminal Wire Range (AWG)	Wire Size	Wire Barrel Crimp			Insulation Support Crimp Width
			Width	Height ¹ ±0.05 [±.002]	Height ² ±0.05 [±.002]	
0.51 ±0.05 [.020 ±.002]	18-14	18	3.81 [.150]	1.90 [.075]	1.90 [.075]	3.56 [.140]
		16		2.16 [.085]	2.03 [.080]	
		14		2.29 [.090]	2.16 [.085]	

¹ Stainless Steel Terminal

² Phosphor Bronze Terminal

Figure 3

91AS-2

3.6. Crimp Pull-Out Test

Crimped grounding clips shall not be separated from their wires when subjected to forces given in the following table.

NOTE

Adjust tensile testing machine for head travel of 25.4mm [1 inch] per minute. Directly and gradually apply force for one minute.

CRIMP PULL-OUT TEST FORCES		
Wire Size [AWG]	Minimum Force	
	Newtons	[Pounds]
[18]	156	[35]
[16]	200	[45]
[14]	267	[60]

3.7. Installation

To apply grounding clip to panel, follow steps shown in Figure 4.

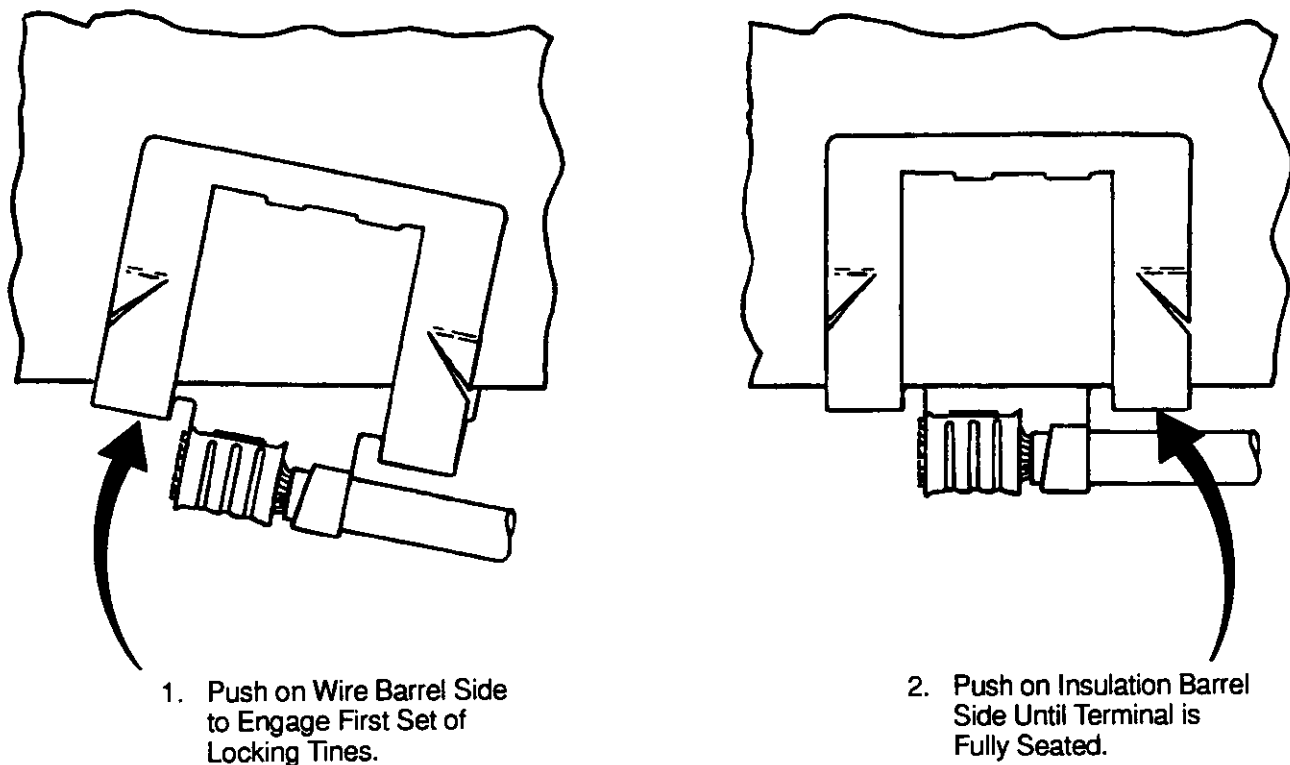
CAUTION

DO NOT pry clip open during installation.

Figure 4

91AS-3

3.8. Separation Forces

Forces required to separate grounding clip terminals are shown in the following table. Measure the force using a testing device capable of holding the reading.

NOTE *Testing may be done using a gage described in Residential Controls — Quick-Connect Terminals, ANSI/NEMA No. DC2—1982.*

TEST PANEL	CLIP MATERIAL	SEPARATION FORCE NEWTONS [POUNDS]	
		AVG.	MIN.
0.51 ±0.03 [.020 ±.001] Thick Aluminum	Stainless Steel	36 [8]	11 [2.5]
	Phosphor Bronze	22 [5]	13 [3]
0.71 ±0.03 [.028 ±.001] Thick Galvanized Steel	Stainless Steel	80 [18]	53 [12]
	Phosphor Bronze	•	•

- We do not recommend phosphor bronze terminal clips for use on steel panels unless held with a No. 6 Sheet Metal Screw.

4. QUALIFICATION

This product meets the Underwriters' Laboratories, Inc. (UL) Specification for Equipment Wiring Terminals No. 486E. It is recognized under UL Component Recognition Program: Electrical File No. E69905, Vol. 3, Sec. 1.

Qualification to Canadian Standards Association (CSA) Specifications for Grounding Terminals is as follows: CSA 22.2 No. 0- M1982, CSA 22.2 No. 41- M1987:

The phosphor bronze version (Part No. 63575-2) is fully certified under File No. LR7189-174. The stainless steel version (Part No. 63575-1) is only certified with use of 18 AWG wire. Use of 16-14 AWG wire on the stainless steel version is permissible if approved by CSA in the end product.

CAUTION *Stainless steel terminal (Part No. 63575-1) is not rated for continuous current operations; it is intended for use in short-time or pulse current applications only.*

5. TOOLING

We do not recommend using hand tools on terminals with the AMP Tab-Lok feature. We recommend the automatic machines shown in the following table. All applicators used in the machine include integral dies.

These codes are used in the table to identify machines holding listed applicators:

- K = AMP-O-LECTRIC Model "K" Terminating Machine 565435-5 (Customer Manual 409-5128)
- T = AMP "T" Terminating Unit Base Part Nos. 812059, 853500, 854220, 854395 with (Customer Manuals 409-5579, 409-5755, 409-5808, 409-5817) respectively fits into the following automatic machines:
 1. AMPOMATOR IV Basic Machine and its variations (Customer Manual 409-5290)
 2. AMPOMATOR CLS II Lead-Making Machine 815800-1 (Customer Manual 409-5619)
 3. AMPOMATOR CLS III Lead-Making Machine 854400 (Customer Manual 409-5806)

WIRE RANGE (AWG)	INSULATION DIAMETER	APPLICATION TYPE	APPLICATORS	TERMINATING MACHINE	MACHINE TYPE
18 - 14	2.54-3.56 [.100 - .140]	Center-Strip (Middle of Wire)	853100-1	467000-4	Bench "T"
			End-of-Wire	853100-2	467000-1
		812059■			Auto "T" & CLS II
		853500			
		854220			Auto "T" & CLS III
		854395			
		853100-3	565435-5	Bench "K"	

■Base part number that fits AMPOMATOR automatic lead making machines IV, CLS II and CLS III

6. VISUAL AID

The illustration below shows features that will help an assembler recognize a good installation. For dimensional inspection, refer to the details in the preceding pages of this specification.

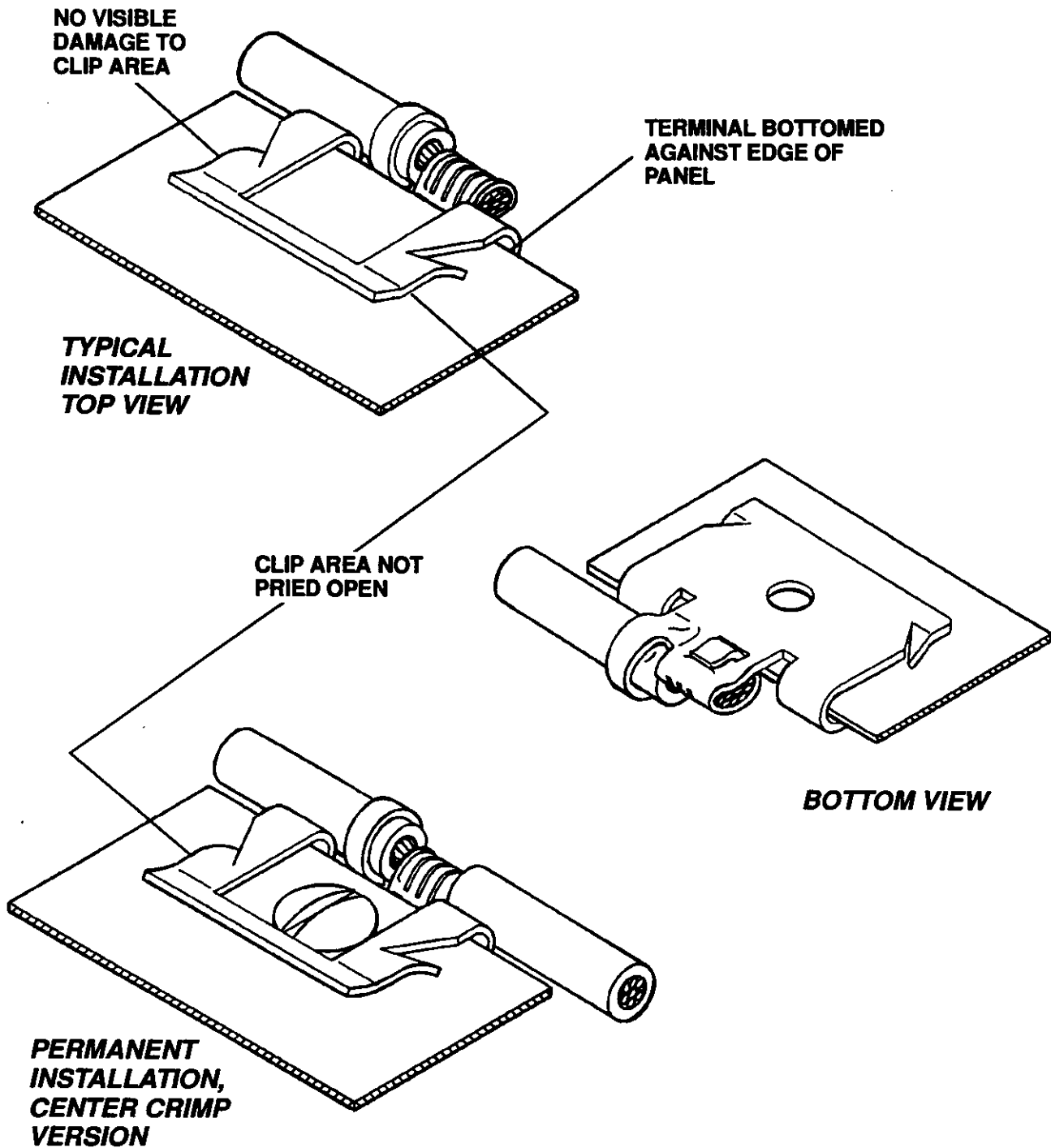
**FIGURE 5. VISUAL AID**

91AS-4