

Jack Module Removal

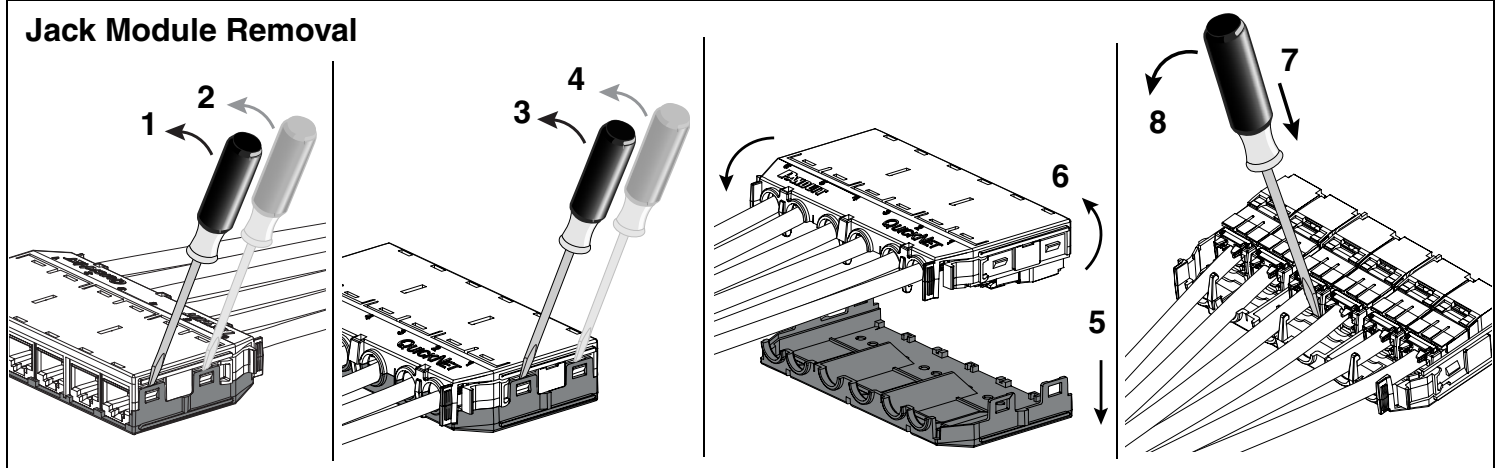

Jack Module Installation

Reference PN364* (10GIG) or PN403* (Cat 6), for jack module termination instructions.

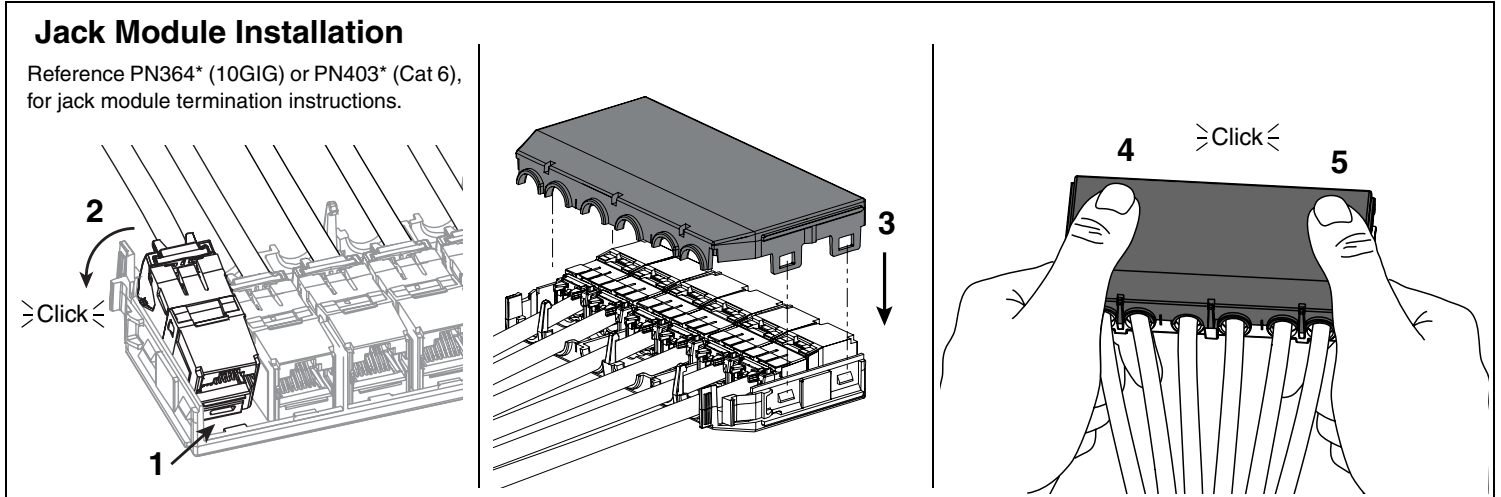

* Denotes Instruction Sheet revision letter.

For Instructions in Local Languages
and Technical Support:
www.panduit.com/resources/install_maintain.asp

PANDUIT
www.panduit.com

E-mail:
cs@panduit.com
Fax:
(708) 444-6993