

READ ALL INSTRUCTIONS COMPLETELY BEFORE PROCEEDING

REFER TO WEB SITE BELOW FOR MOST CURRENT INSTRUCTIONS

1. COMPONENT IDENTIFICATION

JACK

1.1 JACK ASSEMBLY

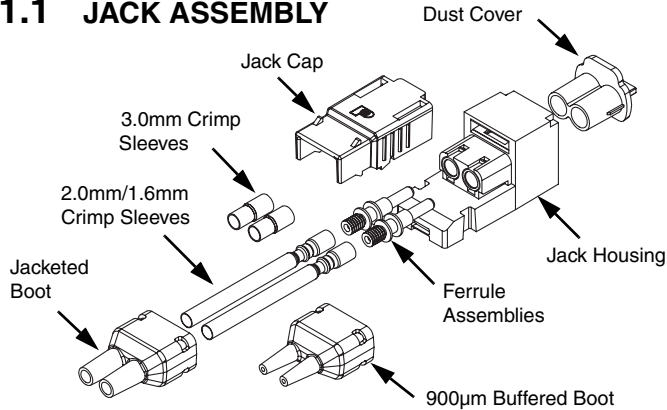

FJJGS9C and FJJGM5C includes 3.0mm crimp sleeves
FJJGS2.0C and FJJGM2.0C includes 2.0mm/1.6mm crimp sleeves

1.2 JACKETED STRIPPING DIMENSIONS

IMPORTANT! Due to printing variations, use a rigid scale for both jack and plug stripping dimensions, or the appropriate **PANDUIT** laminated template.

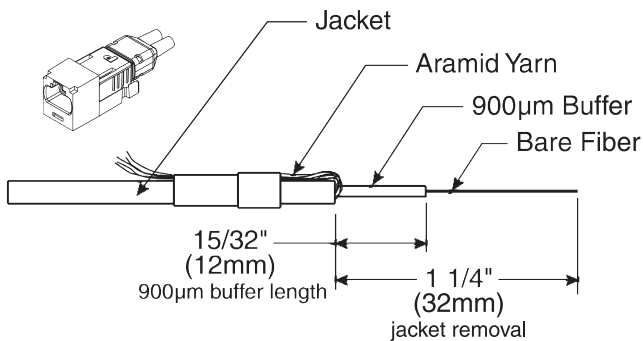

1.3 900µm BUFFERED STRIPPING DIMENSIONS

IMPORTANT! Due to printing variations, use a rigid scale for both jack and plug stripping dimensions, or the appropriate **PANDUIT** laminated template.

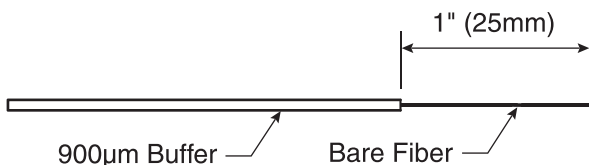

PLUG

1.4 PLUG ASSEMBLY

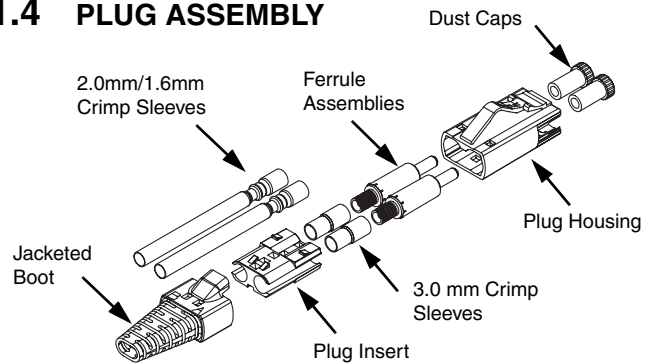

FJEPGS9C and FJEPGM5C includes 3.0mm crimp sleeves
FJEPGS2.0C and FJEPGM2.0C includes 2.0mm/1.6mm crimp sleeves

1.5 JACKETED STRIPPING DIMENSIONS

IMPORTANT! Due to printing variations, use a rigid scale for both jack and plug stripping dimensions, or the appropriate **PANDUIT** laminated template.

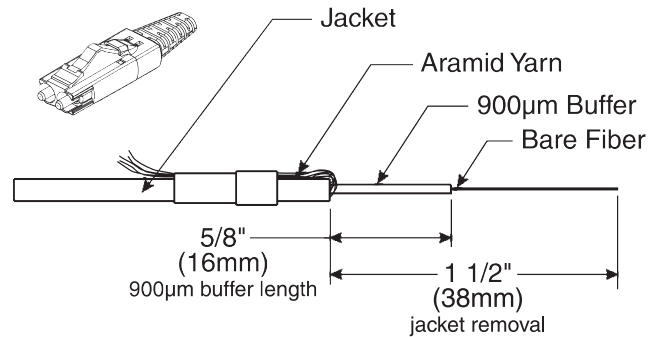

The plug side is not intended to be terminated using 900µm buffered fiber.

1.6 ITEMS REQUIRED FOR TERMINATION

ITEM	PART NUMBER	DESCRIPTION
1	CST-115	Fiber Cable Jacket Stripper
2	FALC	Alcohol Bottle (empty)
3	FBFSP	Fiber Buffer Stripper
4	FCRP5	Universal Crimp Tool (hex sizes: .048, .100, .128, .151, .190) Hex sizes needed for <i>MINI-COM OPTI-JACK</i> termination: .128 and .151
5	FCVR	Fiber Cleaver
6	FGLS	Safety Glasses
7	FJPKGU	Universal Polishing Puck
8	FJPMR	Primer
9	FJPHY	Anaerobic Adhesive
10	FKS	Strength Member (Aramid Fiber) Cutters
11	FPAD	Polishing Pad
12	FPP5-L	5µm Polishing Film (Aluminum Oxide)
13	FSCDVR	Screwdriver
14	FSTY	Safety Stickers for fiber scraps
15	FSWB-C	Cleaning Swabs
16	FSYR-X	Syringes with needle tips
17	FTWZR	Tweezers
18	FWP-C	Cloth Wipes
19	PFX-0	Indelible Ink Marking Pen
20	FLOUPEX10	Eye Loupe 10X Power
21	PPF1-V	1µm Diamond Polishing Film
22	FLPT	Crimp Tool (For 2.0mm/1.6mm terminations only)
23	FHSTC	110VAC/60Hz Heat Shrink Curing Tool (For 2.0mm/1.6mm terminations only)
24	--	Isopropyl Alcohol (Reagent Grade, 90% minimum concentration; not available from <i>PANDUIT</i>)
25	FLCFPLF-X	.05µm Lapping Film (For singlemode terminations only)
26	FWBTL	Distilled Water Bottle (empty)
27	--	Distilled Water (not available from <i>PANDUIT</i>)
OPTIONAL	FHSTC-W	230VAC/50Hz Heat Shrink Curing Tool (For 2.0mm/1.6mm terminations only)
OPTIONAL	FJJ9FRL-X	Replacement ferrule and crimp sleeve for <i>OPTI-JACK</i> singlemode jack (10)
OPTIONAL	FJEP9FRL-XY	Replacement ferrule and crimp sleeve for <i>OPTI-JACK</i> singlemode plug (10)
OPTIONAL	PN257	Stripping Template

2. PRECAUTIONS

2.1 SAFETY GLASSES

WARNING: Safety glasses have to be worn when handling the adhesive or primer used with the connector or when handling bare optical fiber. The bare fiber is very sharp and can easily damage the eye.

2.2 ISOPROPYL ALCOHOL

WARNING: Isopropyl alcohol is flammable. Contact with the alcohol can cause irritation to the eyes. In case of contact with the eyes, flush with water for at least 15 minutes. Always use isopropyl alcohol with proper levels of ventilation. In case of ingestion, consult a physician immediately.

2.3 RECOMMENDED ADHESIVE AND PRIMER

WARNING: The recommended adhesive (*PANDUIT* Part #FJPHY) may contain maleic acid and methacrylic ester. In case of eye contact, flush with water for 15 minutes and get medical attention. Wash after skin contact. Request M.S.D.S. for further safeguards. Check "Used By" date on bottle to ensure best performance.

WARNING: The recommended primer (*PANDUIT* Part #FJPMR) may contain acetone. The primer is harmful if inhaled or swallowed. In case of contact with eyes or skin, flush with water. Get medical attention in case of ingestion or contact with eyes. Do not induce vomiting. Check "Used By" date on bottle to ensure best performance.

2.4 DISPOSAL OF BARE FIBERS

WARNING: Pick up and discard all pieces of bare fiber with sticky tabs. Do not let cut pieces of fiber stick to clothing or drop in the work area where they are hard to see and can cause injury.

2.5 LASER LIGHT PROTECTION

WARNING: Laser light is invisible. The invisible light is powerful enough to damage your eyes. Serious damage to the retina of the eye is possible. Never look into the end of a fiber which may have a laser coupled into it. Should accidental eye exposure to laser light be suspected, arrange for an eye examination immediately.

2.6 CABLE HANDLING

WARNING: Fiber optic cable can be damaged by excessive pulling, twisting, crushing or bending stresses. Consult the appropriate specification sheets as provided by your cable vendor. Any damage may result in decreased optical performance.

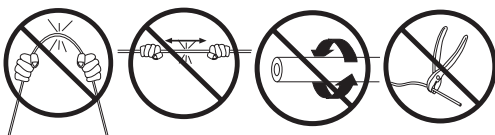
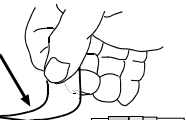
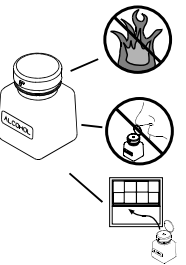

For Technical Support: www.panduit.com/resources/install_maintain.asp

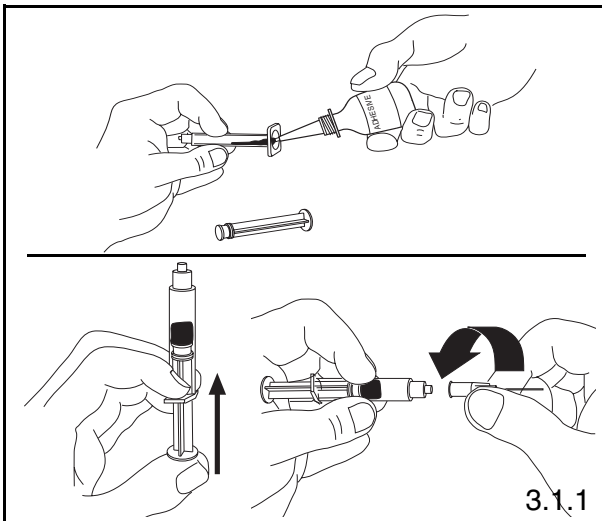

3.1.1

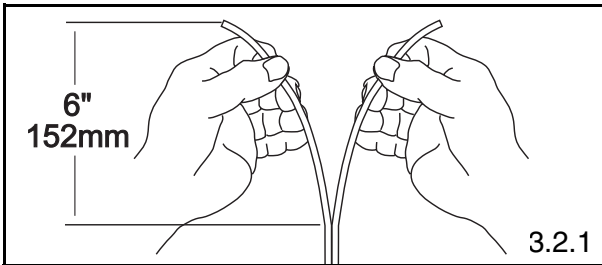

3.2.1

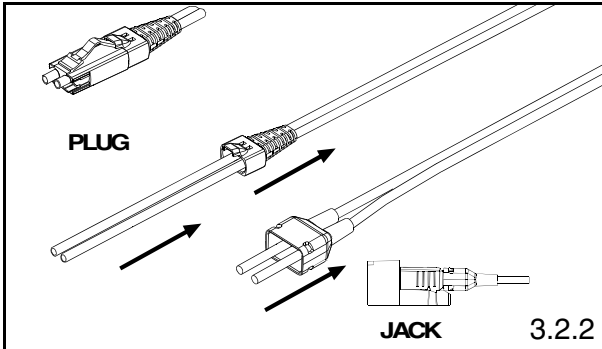

3.2.2

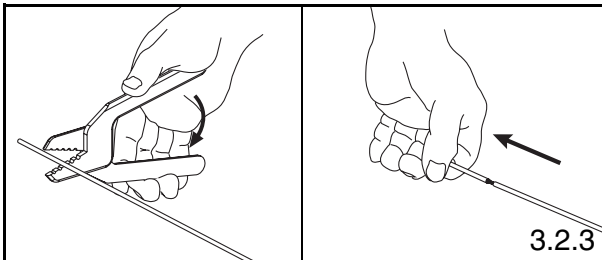

3.2.3

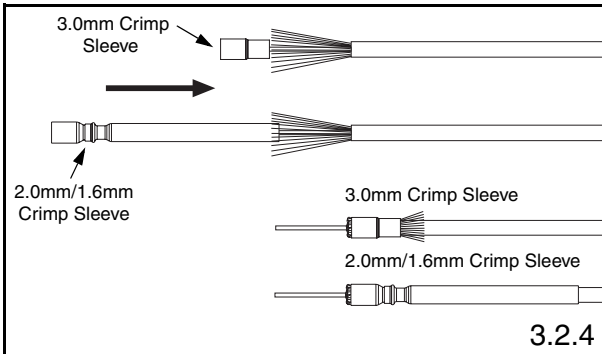

3.2.4

3. FERRULE TERMINATION

3.1 TERMINATION PREPARATION

- 3.1.1 Remove the plunger from a syringe. Squeeze about 0.5 ml of FJPXY Anaerobic Adhesive into the back of the syringe barrel. Insert the plunger. Point opening upward, and squeeze any air out of the barrel. Attach needle to syringe. Adhesive that is stored in a syringe may start to harden within 24 hours.
- 3.1.2 Partially fill a second syringe with about 0.5ml of FJPMR Primer. Do this by drawing primer up into the syringe barrel rather than pouring it in through the back.

3.2 3.0mm/2.0mm/1.6mm JACKET / 900µm BUFFER STRIPPING

- Refer to Page 1 or appropriate *PANDUIT* laminated template for stripping dimensions.
- 3.2.1 **For jacketed duplex cable:** Split the two cables approximately 6" (152mm) or as needed depending on desired jacket stripping length.
- 3.2.2 Insert the fiber end through the small end of the appropriate boot for your specific fiber type. Slide the boot back out of the way.
Note: For plug termination only, maintain proper orientation of the fibers by using the 'A' and 'B' marks on the plug insert and boot to your specific wiring convention.
- 3.2.3 **For jacketed cable only:** To reduce wear on the jacket stripper blades, do not slide the blades along the aramid yarn. Instead, use the tool to cut through the jacket, then pull off the jacket by hand. **For 3.0mm jacketed fiber,** use the third hole (marked "1.3MM" or #16AWG) from the tip of the jacket stripper. **For 2.0mm/1.6mm jacketed fiber,** use the first hole (marked ".80MM" or #20AWG) from the tip of the jacket stripper. Using the cable jacket stripper, strip the required length of the jacket off of each fiber according to the stripping dimensions.
- 3.2.4 **For jacketed cable only:** Insert each fiber through the smaller end of the crimp sleeve. Use the crimp sleeve to fold the aramid yarn back over the jacket, holding it out of the way.
- 3.2.5 **For jacketed cable only:** Use the marking pen and stripping dimensions provided to mark each buffer from the end of the jacket.
- 3.2.6 **For 900µm buffered fiber only:** Using the marking pen, place a mark 1" (25mm) from the end of the buffer.
- 3.2.7 With the buffer stripper provided, strip the buffer.

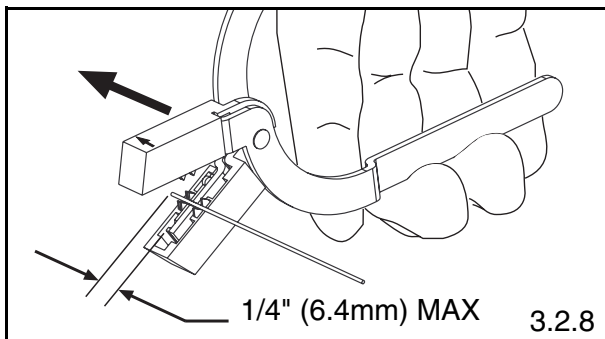

3.2.8 Repeat for the second fiber.

BUFFER STRIPPER GUIDELINES:

- PANDUIT recommends that you remove no more than 1/4" (6.4mm) of buffer at a time to avoid breaking the fiber. Refer to cable manufacturer's buffer stripping guidelines for specific recommendations.
- Hold the buffer stripper such that the arrow on the tool points in the direction of buffer removal.
- Noting the location of the tool's blades, position the fiber in the tool's V-notches. Squeeze the handles firmly and pull tool in the direction of the arrow on the tool.
- Clean the buffer stripper blades after each strip by holding the handles open, pulling the casings back away from the blades, and letting them snap back against the blades.

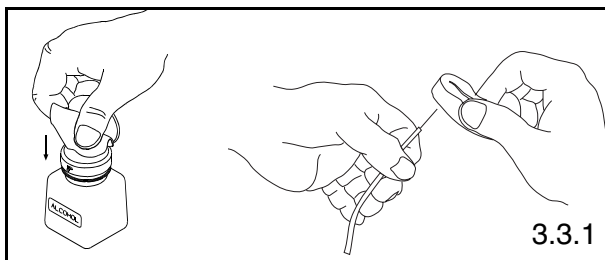

3.3 FERRULE ATTACHMENT

Instructions intended for anaerobic adhesive only.

3.3.1 Clean bare fiber using an alcohol (90% minimum concentration) soaked lint-free wipe. The fibers should be free of all coating and residue after cleaning. Insert fiber without adhesive or primer into ferrule assembly to ensure a proper fit and to remove any debris which may be blocking the ferrule hole. Remove fiber, clean fiber again, and proceed to the next step.

3.3.2 Apply primer onto the bare fiber with the brush from the primer bottle, and onto the first 1/8" (3.2 mm) of the buffer next to the exposed fiber. Set fiber aside such that it will not collect debris while completing the next three steps.

3.3.3 Insert the needle of the adhesive filled syringe into the ferrule assembly until the needle bottoms against the rear of the ferrule.

3.3.4 While pressing the needle firmly against the rear of the ferrule, gently squeeze the syringe plunger until you see a small bead of adhesive form on the front tip of the ferrule. Pull syringe out of the ferrule assembly.

Note: If a heat cured epoxy is used rather than the anaerobic adhesive, do not expose the connector to temperatures in excess of 75°C (167°F).

3.3.5 Carefully but quickly insert the bare fiber through the ferrule in a smooth forward motion. The fiber is fully inserted when the buffer bottoms against the rear of the ferrule. The adhesive will begin to set within seconds.

Note: If adhesive oozes out the back of the assembly, you have injected too much. It is critical to the function of the connector that you wipe away all excess adhesive.

3.3.6 To speed hardening of the adhesive, apply a small drop of primer to the adhesive bead on the ferrule tip using the primer filled syringe. Do not allow the primer to come in contact with the plastic housing of the ferrule assembly. Absorb any primer and unhardened adhesive from the ferrule tip by gently dabbing it with the corner of a lint-free wipe. **Be careful not to break the fiber.**

3.3.7 Repeat for the second fiber.

3.3.8 Allow one minute for the adhesive to harden before cleaving.

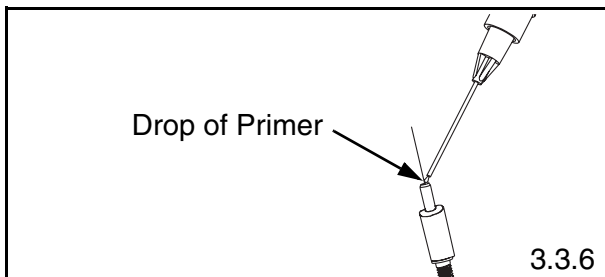
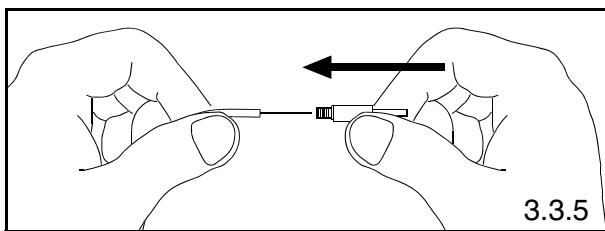
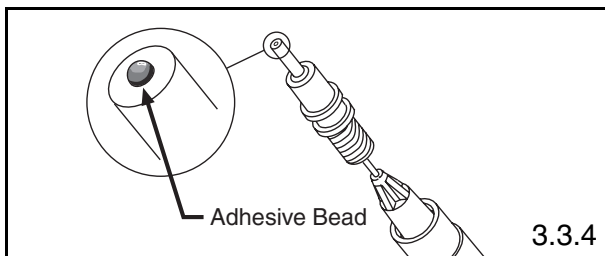

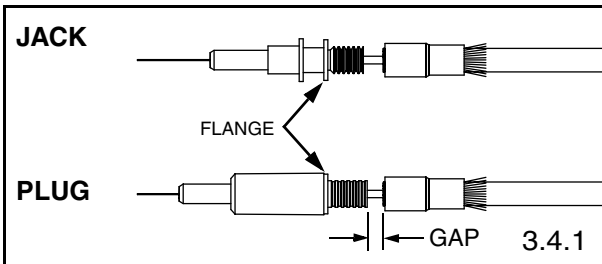

3.4 CRIMPING

For jacketed cable only.

Note: Be careful not to break the bare fibers protruding from the ferrules during this step.

3.4.1 Slide the crimp sleeve back, freeing the aramid yarn. The cable jacket should nearly touch the rear of the backbone of the ferrule assembly.

Note: Do not press the cable jacket forward to touch the rear of the backbone. There should be a gap between the jacket and backbone.

3.4.2 With the appropriate strength member (aramid yarn) cutters, cut the aramid yarn even with the flange.

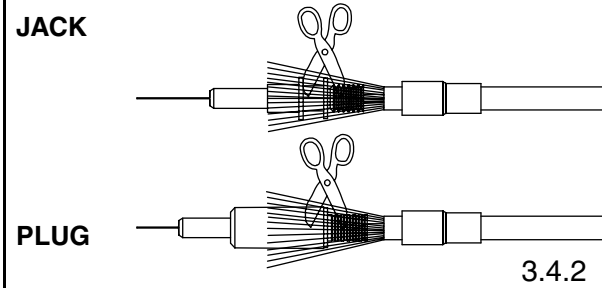

3.4.3 Flare the aramid yarn **evenly** around the perimeter of the grooved area of the backbone of the ferrule assembly. **For 2.0mm/1.6mm jacketed cable**, use tweezers for best results.

3.4.4 Slide the crimp sleeve over the backbone, trapping the aramid yarn between the crimp sleeve and the grooved area of the backbone.

3.4.5 **For 3.0mm jacketed cable:** Make sure the crimp sleeve is seated against the flange of the backbone, crimp the large end of the crimp sleeve using a .151" hex of the FCRP5 Universal Crimp Tool. Using the .128" hex of the crimp tool, crimp the small end of the crimp sleeve over the cable jacket.

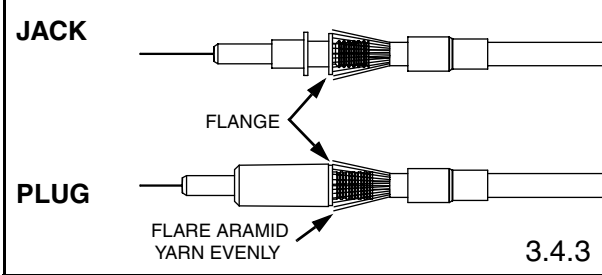

3.4.6 **For 2.0mm/1.6mm jacketed cable:** Align the front edge of the crimp sleeve with the front recessed edge of the die pocket of the FLPT crimp tool.

Note: The front recessed edge of the crimp die pocket is the side with the ribs.

Make sure the crimp sleeve is seated against the backbone and crimp the crimp sleeve.

3.4.7 Repeat for the second ferrule assembly.

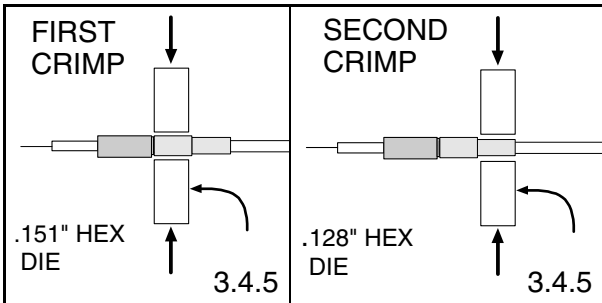

3.5 CLEAVING

3.5.1 Using a cleave tool, gently make one small score mark across the bare fiber just above the endface of the ferrule. Pull the fiber away from the ferrule and discard it on one of the sticky tabs provided. A short stub of fiber protruding from the tip of the ferrule should be visible when viewed through the FLOUPEX10 Eye Loupe.

3.5.2 Repeat for the second ferrule assembly.

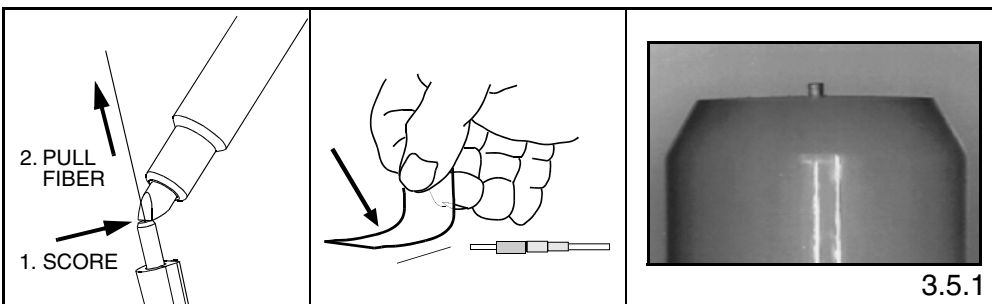
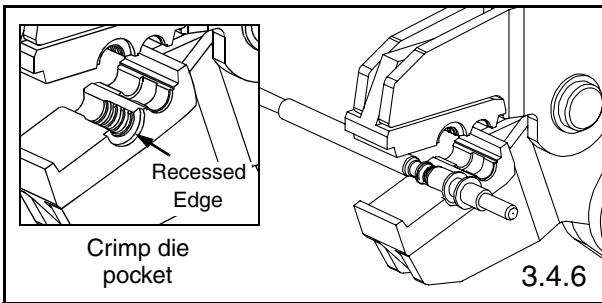

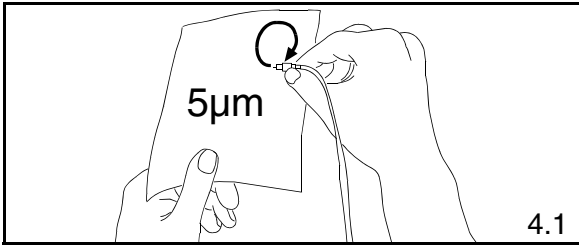

4.1

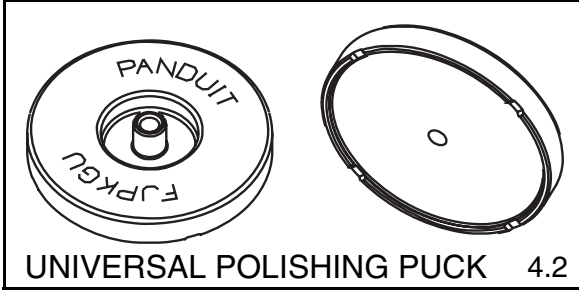

UNIVERSAL POLISHING PUCK 4.2

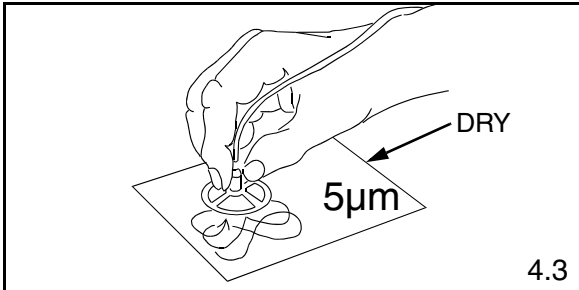

4.3

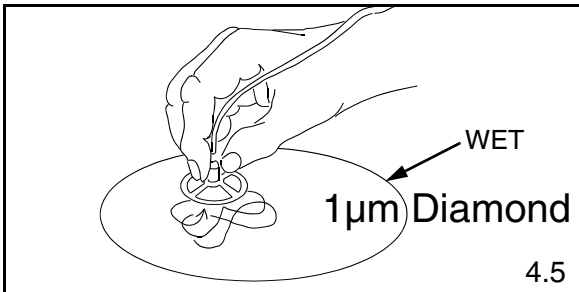

4.5

Ferrule Tip After 1µm Diamond Polish

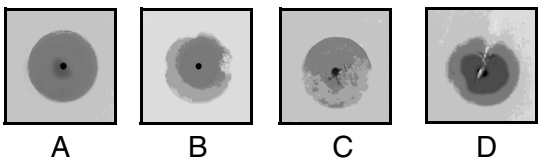

A B C D

- A= Ideal. No blemishes on core or cladding.
- B= Good. Cladding is chipped, but core is not.
- C= Poor. Scratch across core. Try repolishing or else reterminate.
- D= Unacceptable. Fiber has shattered. Reterminate.

4.6

4. POLISHING

Carefully read this entire section before proceeding.

POLISHING GUIDELINES

- Keep the puck flat against the polishing film.
- Figure eights should be about 3" tall and 1.5" wide.
- Always polish on a clean area of the 5µm (micron) polishing film, with figure eights traversing the film as shown in Figure 4.3.
- One sheet of 5µm (micron) polishing film will polish 2-4 ferrules.
- One sheet of 1µm diamond polishing film will polish 100 ferrules.
- One sheet of .05µm lapping film will polish approx. 18-20 ferrules.
- Clean the polishing puck and pad with a clean wipe after each step.
- DO NOT OVERPOLISH.

Repeat each step for each ferrule assembly.

- 4.1 Hold a piece of the 5µm (micron) polishing film in the air and gently rub the fiber stub against it in a circular motion until the height of the fiber stub is equal to or slightly less than its diameter. This is indicated when the white trace on the film is no longer obvious. Make sure fingers are at the edge of the film, not directly behind fiber.
Note: Do not use the same 5µm (micron) film used in this step for any of the following polishing steps.
- 4.2 Thoroughly clean polishing puck, puck hole, and pad with alcohol and cleaning swab. Place a separate sheet of 5µm (micron) polishing film on the soft side of the polishing pad. Set the polishing puck on the polishing film.
- 4.3 Carefully insert the ferrule assembly into the puck hole until the ferrule/fiber contacts the polishing film. While keeping the puck flat against the film, apply very light pressure on the ferrule assembly making figure eight motions with the puck. Gradually increase pressure until the fiber stub no longer leaves a white trace on the film (about 10 figure eights). At this point, the adhesive will be gone.
- 4.4 Remove 5µm polishing film from polishing pad. Clean the ferrule tip, pad, and bottom of the puck with an alcohol soaked wipe.
- 4.5 Place a sheet of 1µm diamond polishing film onto the polishing pad. Place several drops of distilled water on the diamond film. Polish the fiber endface with the puck using medium pressure for approximately 10 figure eights.
- 4.6 Clean the ferrule tip and puck with an alcohol soaked lint-free wipe. Clean the 1µm diamond film using an alcohol soaked wipe after every 5 connectors.
- 4.7 Inspect the fiber endface using a microscope. If scratches remain, repeat steps 4.5 and 4.6.
WARNING: NEVER LOOK INTO THE END OF A FIBER WHICH MAY HAVE A LASER COUPLED INTO IT.
Note: Each time a mating takes place, clean the ferrule endface thoroughly with an alcohol soaked lint-free wipe.
- 4.8 **For singlemode only:** Place a sheet of the .05µm lapping film on the pad. Apply several drops of distilled water onto the center of the film.
- 4.9 **For singlemode only:** Place the puck in the center of the distilled water on the film and pad. Keeping the puck flat against the film and pad, apply even pressure for 4 figure eights.
- 4.10 **For singlemode only:** Wipe the ferrule, pad, and puck with a **dry** wipe.
- 4.11 **For singlemode only:** Clean the ferrule with a distilled water soaked wipe. **Do not use alcohol to clean after using the .05µm lapping film.**

5. CURING HEAT SHRINK TUBING

For 2.0mm/1.6mm jacketed cable only.

- 5.1 Turn the heat adjustment knob of the heat shrink curing tool so the white line is centered in the notch.
- 5.2 Turn heat shrink curing tool "on". (The temperature of the hot air stream at the nozzle should be 220°F - 240°F)
- 5.3 Hold onto the connector and support the cable.
- 5.4 Bring the heat shrink tubing into the hot air stream. Hold the heat shrink tubing about 1/2" away from the nozzle. Rotate the connector for 20-30 seconds so that the heat shrink tubing is completely cured onto the jacket.
- 5.5 Remove the connector from the hot air stream.
- 5.6 Turn heat shrink curing tool "off".

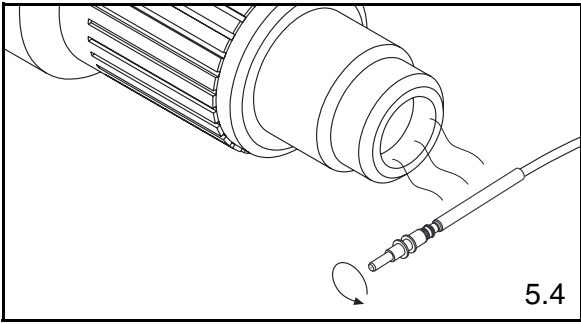

5.4

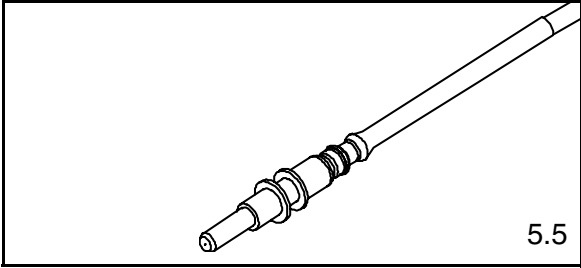

5.5

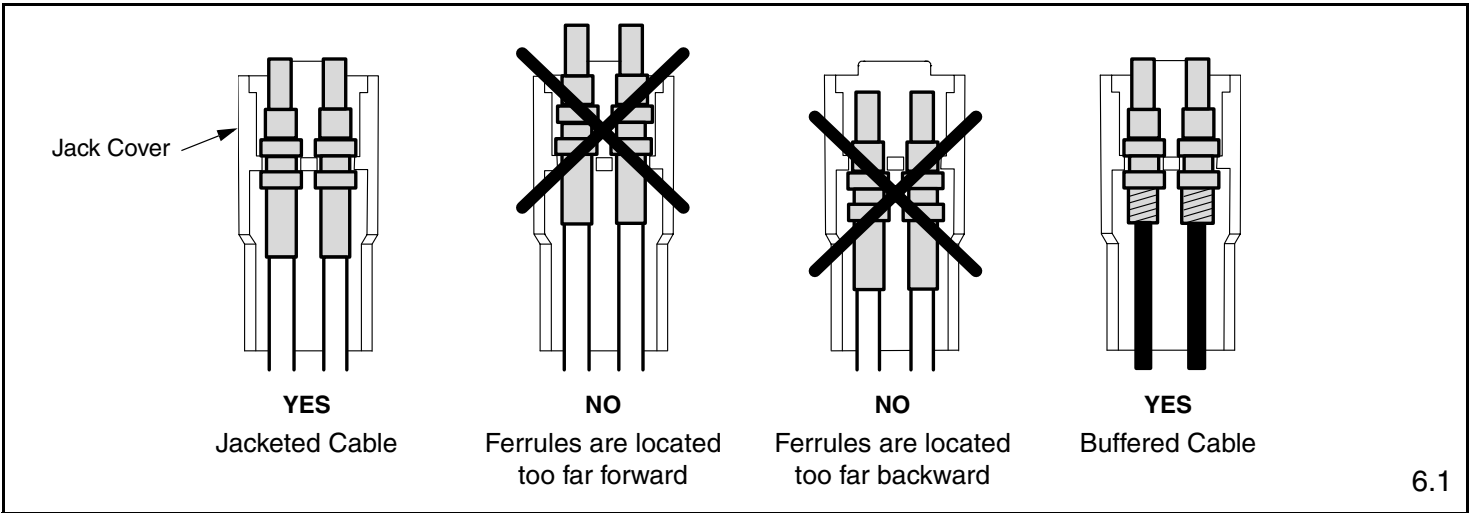

6.1

6. JACK ASSEMBLY

- 6.1 Turn the snap-on jack cover over in your hand so that the 'A' and 'B' marks inside the cover are facing you and are upright. Then, place each ferrule assembly in the jack cover. Maintain proper orientation of the fiber runs by using the 'A' and 'B' marks to your specific wiring convention.
- 6.2 Slide the boot up to the cover until the holes of the boot lock on to the tabs of the cover.
- 6.3 Next, position snap-on jack cover behind the jack housing. The ferrules should start to enter the split sleeves which are held within the jack housing. Slide cover forward, aligning the rails in the cover and jack housing.

Note: If you are using OPTI-JACK Keyed connectors, verify that plug mates with intended jack.

FJJGM5CWBL	→	FJEPGM5CWBL
FJJGM5XRD	→	FJEPGM5XRD
FJJGM5CYOR	→	FJEPGM5CYOR
FJJGM5CZYL	→	FJEPGM5CZYL

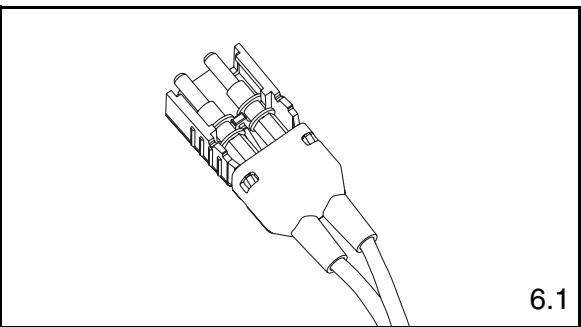

6.1

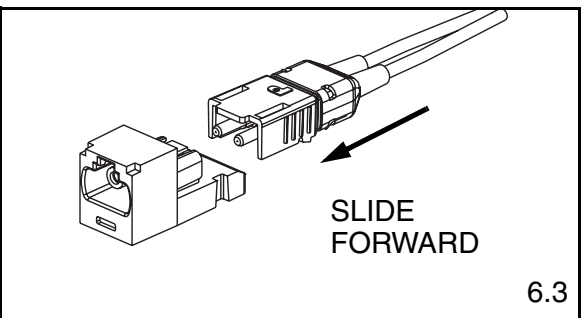

6.3

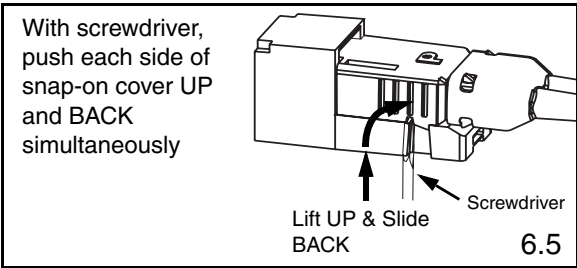

- 6.4 Finally, push the snap-on cover forward until it clicks into place.
- 6.5 Should it be necessary to remove the ferrules, the snap-on cover can be removed by simultaneously lifting and sliding with a small screwdriver.
- 6.6 To clean the jack ferrules once they are enclosed in the jack housing, use the lint-free swabs. Gently insert a swab through the split sleeve to wipe the jack ferrule endface. Swabs can be moistened with alcohol.
- 6.7 The jack dust cover should be inserted to keep the jack housing clean when the jack is not in use.

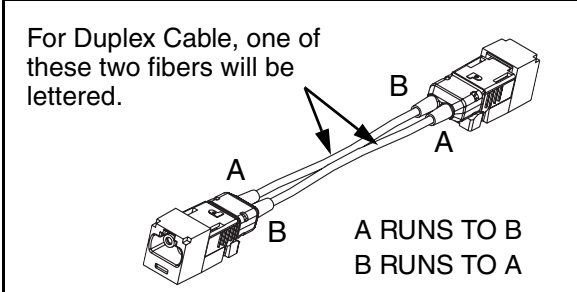

7. PLUG ASSEMBLY

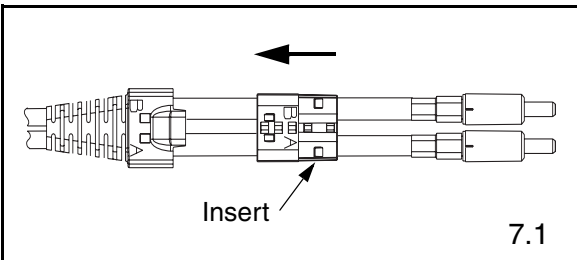

- 7.1 Place the insert onto the cables between the boot and terminated ferrule assemblies by sliding the cables into the slots on the side of the insert. Be careful not to pinch the cable. The "A" and "B" on the insert should line up with the "A" and "B" on the boot.
- 7.2 Slide the insert inside the boot until the tabs on the insert lock into the holes on the boot.
- 7.3 Push the ferrule assemblies into the housing. Make sure the cables are not crossed inside the assembly. The latch on the housing should be on the same side as the hood on the boot.

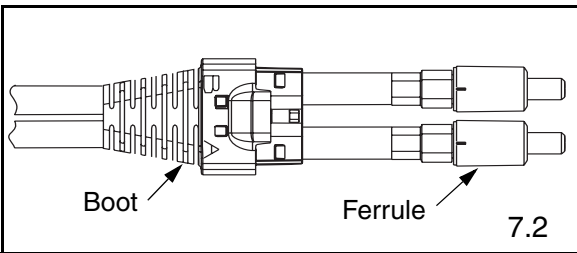

Note: If you are using OPTI-JACK Keyed connectors, verify that plug mates with intended jack.

FJJGM5CWBL	→	FJEPGM5CWBL
FJJGM5CXRD	→	FJEPGM5CXRD
FJJGM5CYOR	→	FJEPGM5CYOR
FJJGM5CZYL	→	FJEPGM5CZYL

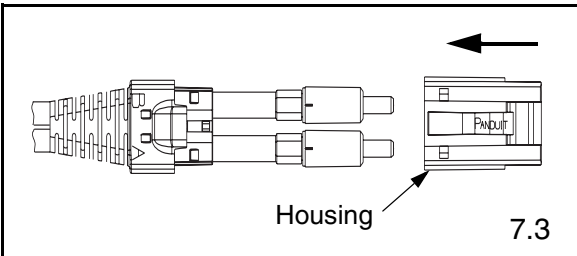

- 7.4 With the ferrule assemblies inside the housing, push the boot/insert assembly into the housing until it snaps in place.
- 7.5 Immediately after assembly, place the black dust caps over the ferrule ends.

