

Hardware Guide

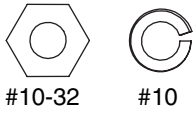

#10-32 #10

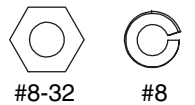

#8-32 #8

List of Components:

- (4) #10-32 Hex Nuts
- (4) #10 Split Lock Washers
- (4) #8-32 Hex Nuts
- (4) #8 Split Lock Washers
- (1) Grounding Cable
- (4) Pieces of Fire Resistant Foam
- (1) 26" length Grommet Edging
- (1) 2 Position Surface Mount Box (PANDUIT Part No. CBXJ2WH-A)
- (1) 2' long Cat5 Patch Cord (PANDUIT Part No. UTPCH2)
- (1) Cat5e Jack Module (PANDUIT Part No. CJ5E88TWH)
- (1) Foam Retention Plate
- (1) Slot Cover
- (1) Key

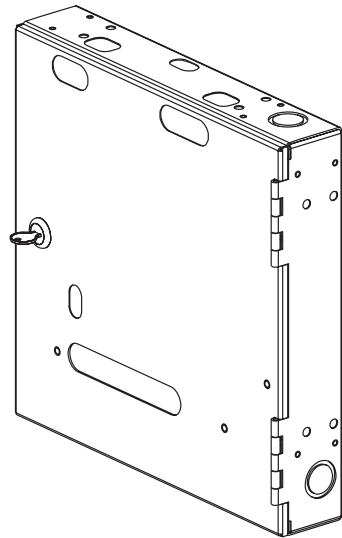

PZWIFIE

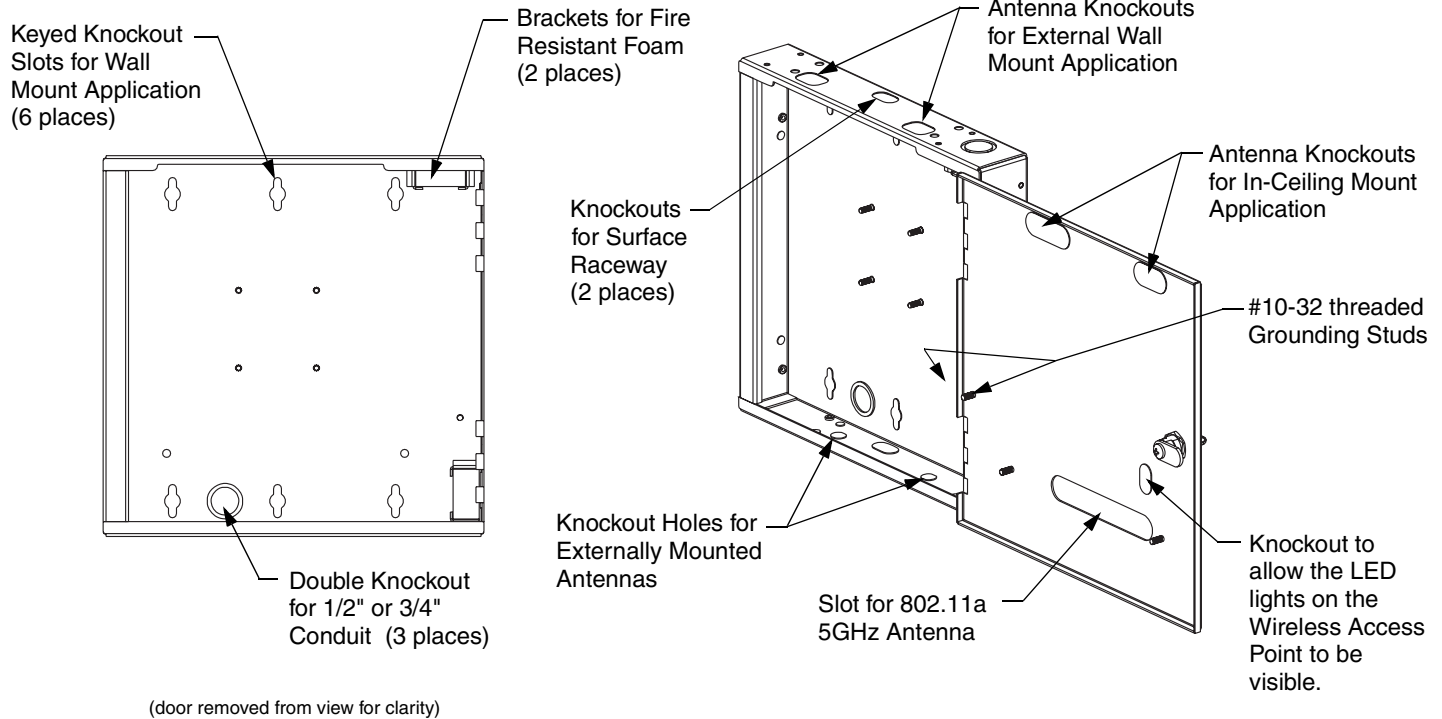

TABLE OF CONTENTS

Page (s)

External Wall Mount Installation	2-4
Optional Flush Wall Mount Installation	4
In-Ceiling Mount Installation	5-8

EXTERNAL WALL MOUNT INSTALLATION

Refer to the installation and configuration guidelines provided by the manufacturer of the wireless access point to determine the optimum enclosure installation location and antenna configuration.

Please read these instructions in their entirety prior to installing the enclosure.

Step 1: Knockout Removal

- 1.1 Determine whether the network cable will be routed into the enclosure through conduit or surface raceway. Remove the appropriate knockouts.

For Conduit - Remove knockout "A", "B" or "C". This double knockout accommodates either 1/2" or 3/4" conduit.

For Surface Raceway - Remove knockout "D" or "E". This opening accommodates *PANDUIT* LD10 surface raceway.

- 1.2 Determine the antenna type that will be used. Remove the appropriate knockouts.

If 2.4GHz Standard Dipole Antennas will be used with the Wireless Access Point (WAP) - Remove knockouts "F".

For Externally Mounted Antennas - Remove knockouts "G". An antenna patch cord (not included) is required for this application.

- 1.3 Locate the wall studs. Position the enclosure on the wall and identify which keyed knockouts should be removed. It is recommended that two of the mounting holes be aligned with the wall stud. Wall anchors (not included) should be used for each additional mounting hole chosen by the installer. Remove desired knockouts.

- 1.4 To view the LED lights on the WAP when the enclosure door is closed, remove knockout "J". Refer to figure 1 on page 5 for location of knockout "J".

Optional: Flexible grommet edging can be used to cover knockout edges if desired.

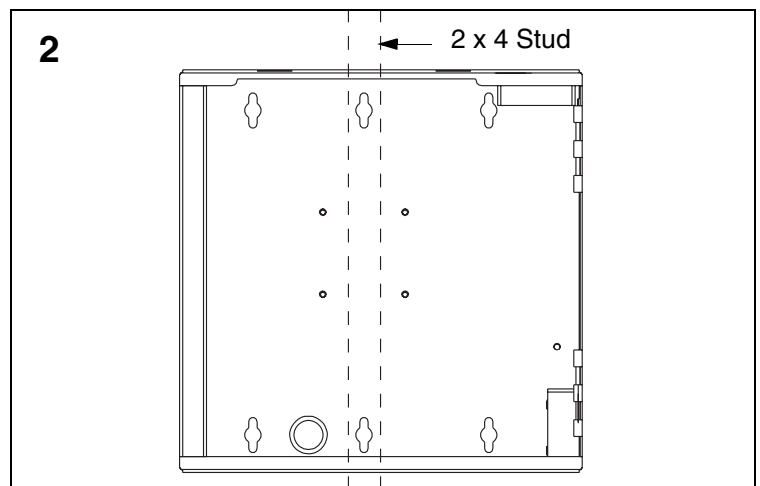
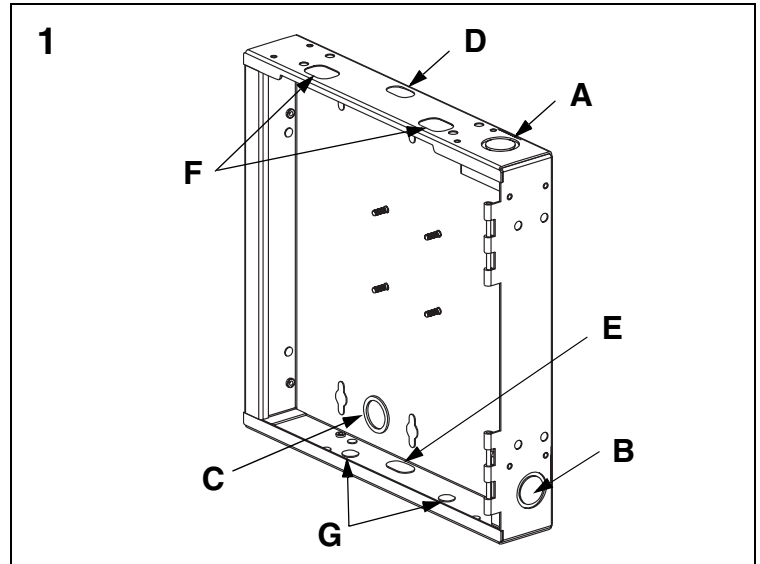

Step 2: Mount Enclosure to Wall

- 2.1 Locate the wall studs.
- 2.2 Hold the enclosure against the wall to mark the location of the mounting holes.
- 2.3 Mount the enclosure to the wall using mounting screws and wall anchors (not included). Enclosure designed for use with #14 screws.

Step 3: Install Wireless Access Point Bracket

- 3.1 Place the Wireless Access Point Mounting Bracket (supplied with the Cisco Aironet 1200 Wireless Access Point) inside the enclosure so the four angled mounting slots align with the four threaded studs on the back wall of the enclosure. Install the bracket in the orientation as shown in the view.
- 3.2 Secure the mounting bracket with the supplied #8 Split Lock Washers and #8-32 Hex Nuts.

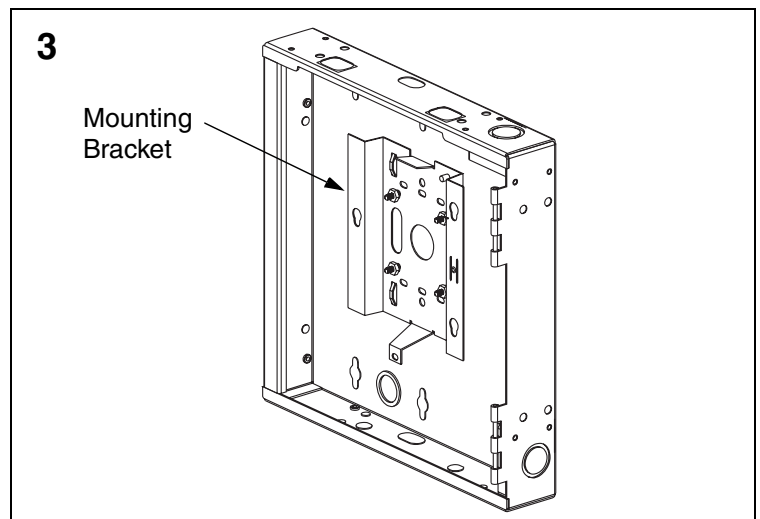

Step 4: Grounding

- 4.1 Run cable from the Telecommunications Grounding Busbar (TGB) to the enclosure and attach to the grounding stud on the base.
- 4.2 Using the supplied Grounding Cable, attach one end to the grounding stud on the base (on top of TGB cable) and the other end to the grounding stud on the door.
- 4.3 Secure with the #10 Split Lock Washers and #10-32 Hex Nuts.

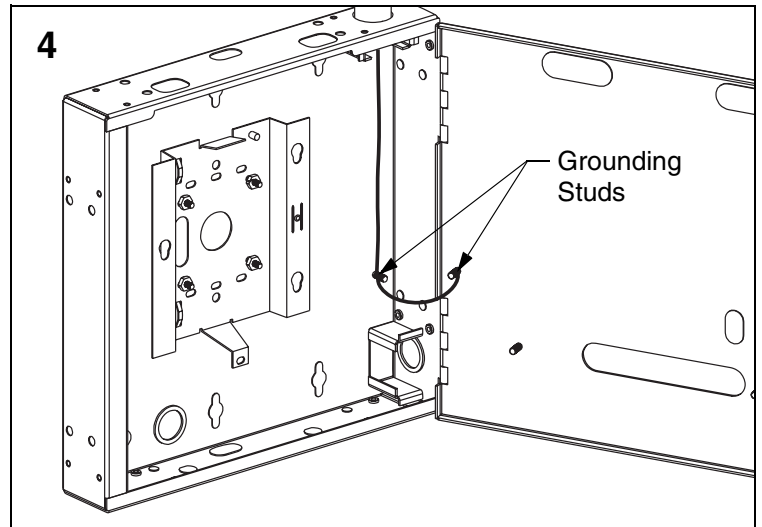

Step 5: Install Wireless Access Point

- 5.1 If 2.4GHz standard dipole antennas will be used, install the antennas onto the WAP before it is mounted in the enclosure. Position the antennas so they are parallel with the front surface of the WAP as shown. When installing the WAP, these antennas will be inserted through knockouts "F".
- 5.2 If the 802.11a 5GHz paddle type antenna will be used, install the antenna on the WAP before it is mounted in the enclosure.
- 5.3 Insert the three mounting pads, located on the bottom surface of the WAP, into the large portion of the three keyed mounting holes on the bracket.
- 5.4 Pull the WAP downward until an audible "snap" is heard. Lightly pull the WAP in the opposite direction to verify that it is properly locked into place.

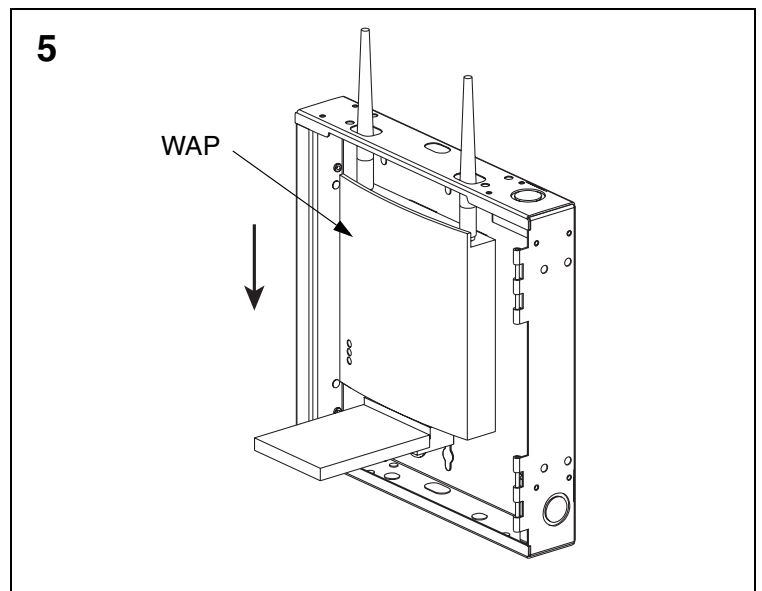

Step 6: Install Surface Mount Box

- 6.1 Run the network cable to and into the enclosure.
- 6.2 Terminate the Cat5e Jack Module to the network cable. Refer to the *PANDUIT* website for jack termination instructions if needed.
- 6.3 Mount the base of the 2 Position Surface Mount Box to the back wall of the enclosure using provided double sided tape.
- 6.4 Snap the terminated jack into position "1" of the box. Place the network cable between the two cable retention tabs on the back of the base.
- 6.5 Remove the breakout tab on the back of the cover.
- 6.6 Snap the cover onto the base.

Note: A second Cat5e Jack Module can be installed in position "2" of the surface mount box to provide access to the serial port on the WAP.

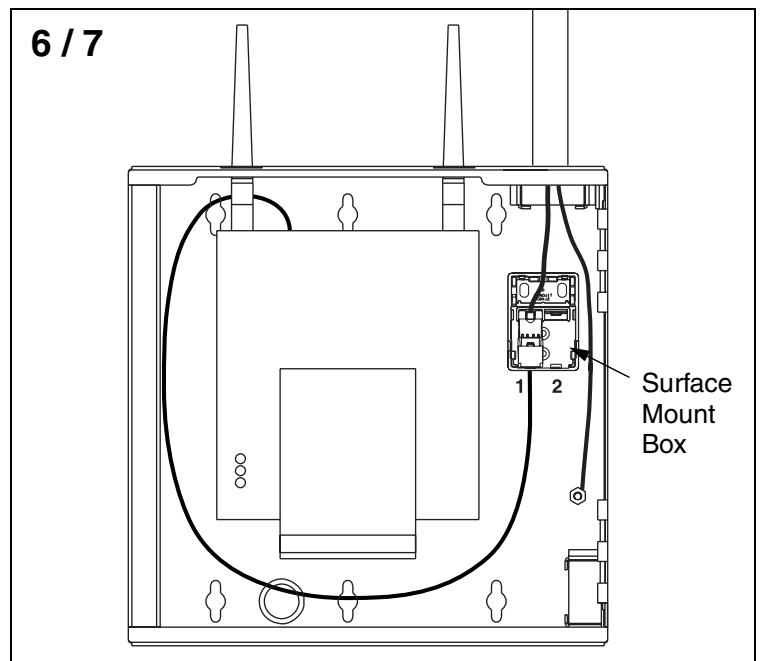

Step 7: Install Patch Cord

- 7.1 Insert one end of the 2' long Cat5 Patch Cord into the RJ45 port located on the WAP.
- 7.2 Insert the other end of the patch cord into the Cat5e jack located in the surface mount box.

Step 8: Install Slot Cover (if needed)

- 8.1 If the 802.11a 5GHz paddle type antenna is not used, the large slot on the door can be covered using the supplied Slot Cover.
- 8.2 Place the Slot Cover over the two threaded studs and secure with the #10 Split Lock Washers and #10-32 Hex Nuts.

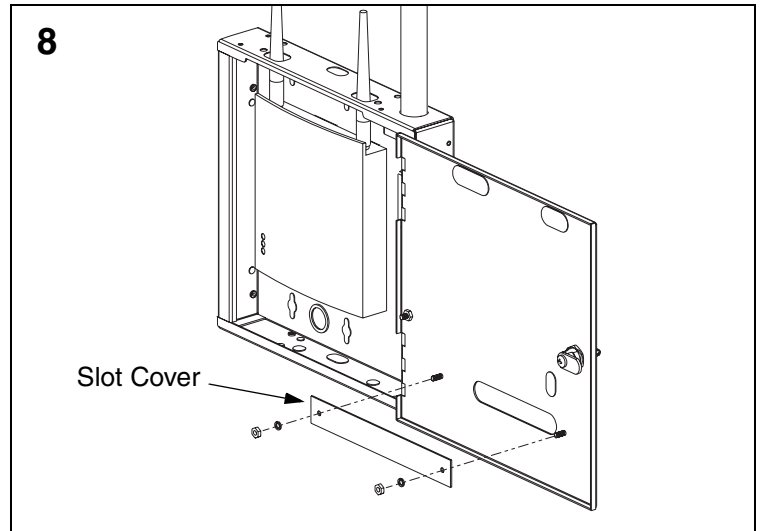

OPTIONAL FLUSH WALL MOUNT INSTALLATION

The enclosure can be mounted flush with the surface of a wall when optional *PanZone Wireless Access Point Ceiling Bracket Kit, PANDUIT Part# PZWIFICB* (sold separately), is used.

1. Knockout Removal

- 1.1 Remove knockouts in desired cable entry location:
 For Conduit - Remove knockout "A" or "B". This double knockout accommodates either 1/2" or 3/4" conduit.
 Without Conduit - Remove knockout "A" or "B".
 Remove the 1/2" diameter opening.
- 1.2 Determine the antenna type that will be used. Remove appropriate knockouts.
 The flush wall mount application is optimized for use with the 802.11a 5GHz paddle type antenna. It is not necessary to remove any knockouts if this antenna type is used.
Note: Please refer to the antenna reference guide provided by the manufacturer of the wireless access point to identify the appropriate antenna configuration if the 802.11b or 802.11g radio modules on the WAP will be used.
- 1.3 Each sidewall of the enclosure has four small knockouts that can be removed to allow 1/4" screws (not included) to secure the enclosure to a stud inside the wall. Determine which side of the enclosure will be secured to the stud and remove the knockouts on that sidewall.
- 1.4 To view the LED lights on the WAP when the enclosure door is closed, remove knockout "J".

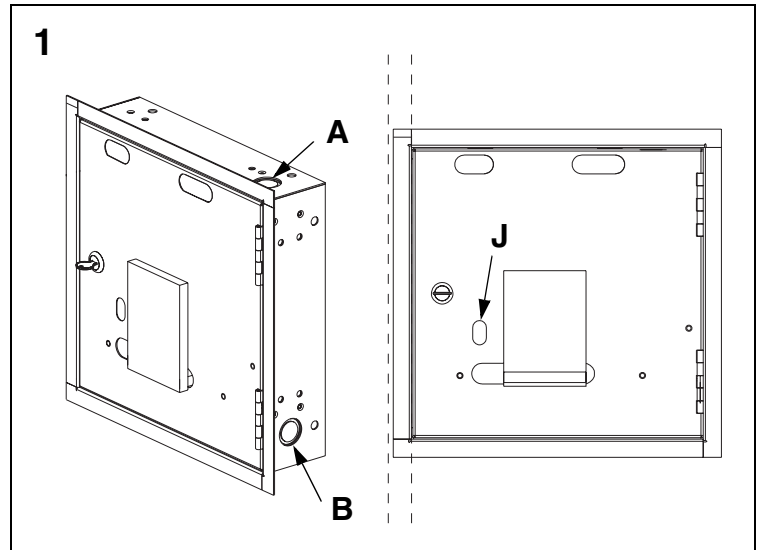

2. Follow "In-Ceiling Mount Installation" Steps 2-3 (pgs 5-6)

3. Mount Enclosure in Wall

- 3.1 Locate the 2 x 4 wall stud and cut a square opening in the wall that is no smaller than 12 1/4" x 12 1/4" and no larger than 12 3/4" x 12 3/4". **Important:** One edge of the square opening must line up with the edge of the wall stud.
- 3.2 Install the enclosure in the wall and secure to the wall stud using four 1/4" screws (not included).

4. Complete installation by following "In-Ceiling Mount Installation" Steps 6-11 (pgs 7-8)

IN-CEILING MOUNT INSTALLATION

Refer to the installation and configuration guidelines provided by the manufacturer of the wireless access point to determine the optimum enclosure installation location and antenna configuration.

Please read these instructions in their entirety prior to installing the enclosure.

Note: PANDUIT Part Number PZWIFICB is required for the in-ceiling mount application.

Step 1: Knockout Removal

- 1.1 Remove knockouts in desired cable entry location:
For Conduit - Remove knockout "A", "B" or "C". This double knockout accommodates either 1/2" or 3/4" conduit.
Without Conduit - Remove knockout "A" or "B".
Remove the 1/2" diameter opening.
- 1.2 If 2.4GHz standard dipole antennas will be mounted to the Wireless Access Point (WAP), remove knockouts "H" on the door.
- 1.3 To view the LED lights on the WAP when the enclosure door is closed, remove knockout "J".

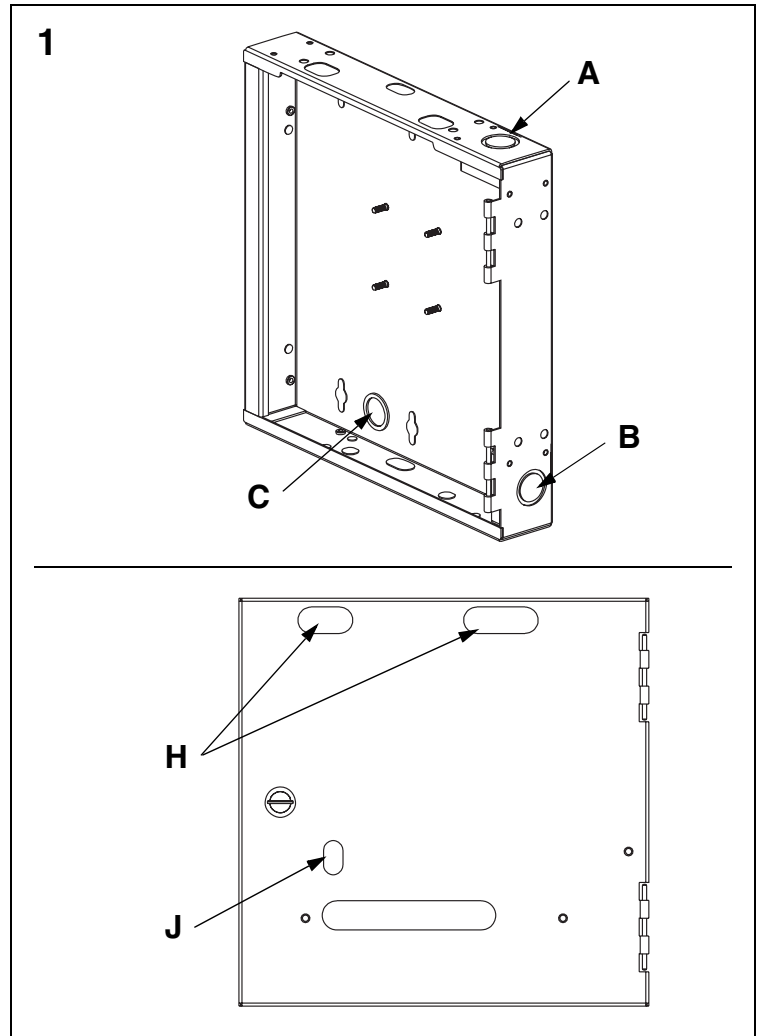

Step 2: Install Wireless Access Point Bracket

- 2.1 Place the Wireless Access Point Mounting Bracket (supplied with the Cisco Aironet 1200 Wireless Access Point) inside the enclosure so the four angled mounting slots align with the four threaded studs on the back wall of the enclosure. Install the bracket in the orientation as shown in the view.
- 2.2 Secure the mounting bracket with the supplied #8 Split Lock Washers and #8-32 Hex Nuts.

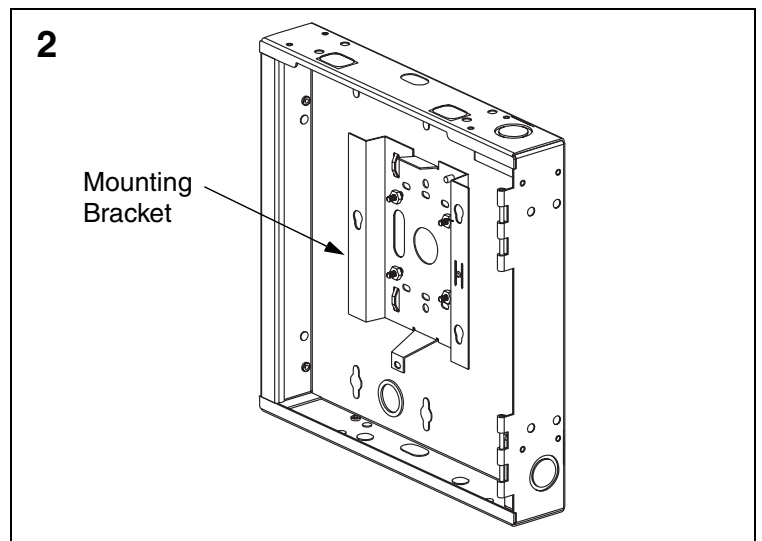

Step 3: Install Ceiling Mount Brackets

PANDUIT Part #: (sold separately)

PZWIFICB - PanZone Wireless Access Point Ceiling Bracket Kit
(4) Ceiling Mount Brackets (16) #6-32 Flat Head Screws

- 3.1 Place one of the Ceiling Mount Brackets against any side wall of the enclosure with the flanged edge facing away from the enclosure. The top of the flanged edge should be even with the enclosure door.
- 3.2 Fasten the bracket to the base of the enclosure using four of the supplied #6-32 Flat Head Screws.
- 3.3 Repeat steps for remaining 3 Ceiling Mount Brackets.

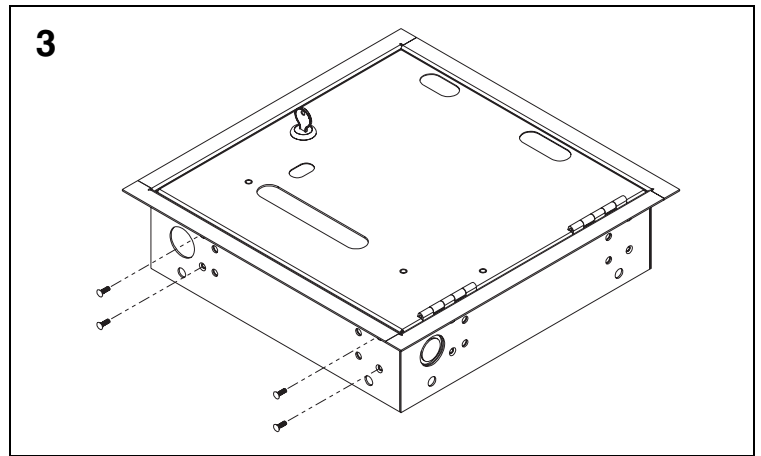

Step 4: Prepare Ceiling Tile

- 4.1 When the enclosure will be mounted in a suspended ceiling, a square hole that is approximately 12 1/2" x 12 1/2" must be cut in the ceiling tile.
- 4.2 It is important that the hole be no smaller than 12 1/4" x 12 1/4" and no larger than 12 3/4" x 12 3/4". This will ease installation and prevent visible gaps around the enclosure once installed.

Note: The bottom edges of the assembled enclosure brackets can be used as a guide to trace the square hole size onto the ceiling tile.

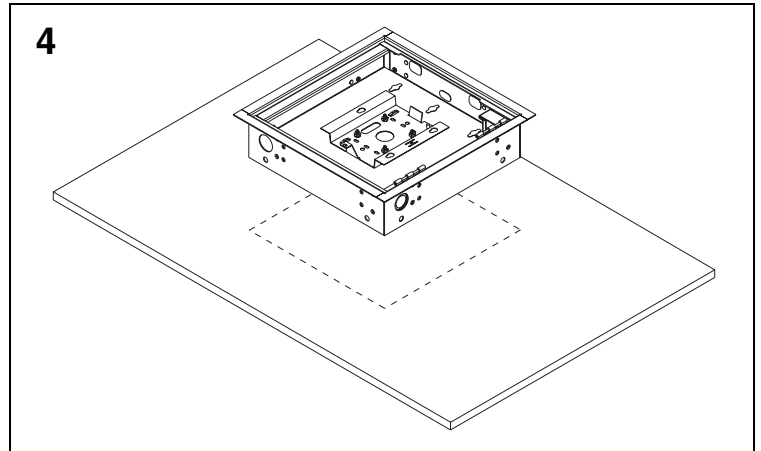

Step 5: Install Enclosure to Ceiling

- 5.1 Hanger wire should be used to hang the enclosure within a suspended ceiling. **Important:** Verify hanger wire meets local building code. Weight of enclosure and WAP does not exceed 8 lbs.
- 5.2 Observe how the hanger wire used to hold the ceiling support grid is secured to the building structure.
- 5.3 Remove one tile adjacent to the tile the enclosure will be mounted in.
- 5.4 Secure four pieces of hanger wire (not included) to the building structure. The hanger wire length will be determined by the installer based on the building structure dimensions above the suspended ceiling. Extend the length of the hanger wire beyond the surface of the ceiling by at least 6".
- 5.5 Add the cut ceiling tile back to the ceiling support grid.
- 5.6 Pull one of the four pieces of hanger wire to one corner of the square opening in the ceiling tile. Pre-bend the hanger wire at a 90° angle approximately 2 1/2" above the surface of the ceiling tile. Repeat this step for the remaining 3 hanger wires measuring to the three remaining corners of the square opening.
- 5.7 Insert the enclosure into the cut ceiling tile opening.
- 5.8 While holding the enclosure flush with the surface of the ceiling tile, route the hanger wire through one of the eight 3/8" dia hanger wire mounting holes and bend up. Pull the wire upward until the enclosure is flush with the

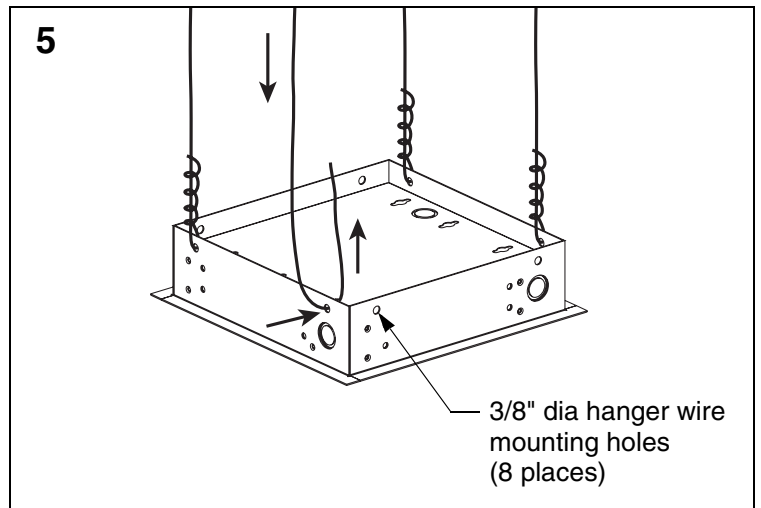

ceiling tile. Repeat this step using the three remaining hanger wires to secure the three remaining corners of the enclosure.

- 5.9 Visually inspect the edges of the enclosure to verify no gaps exist between the mounting brackets and surface of the ceiling tile. If gaps exist, pull the hanger wire upward until the enclosure is tight against the ceiling tile.
- 5.10 To secure the enclosure, wrap each hanger wire tightly around itself a minimum of three times.
- 5.11 Replace the adjacent ceiling tile.

Step 6: Grounding

- 6.1 Run cable from the Telecommunications Grounding Busbar (TGB) to the enclosure and attach to the grounding stud on the base.
- 6.2 Using supplied Grounding Cable, attach one end to the grounding stud on the base (on top of the TGB cable) and the other end to the grounding stud on the door.
- 6.3 Secure with the #10 Split Lock Washers and #10-32 Hex Nuts.

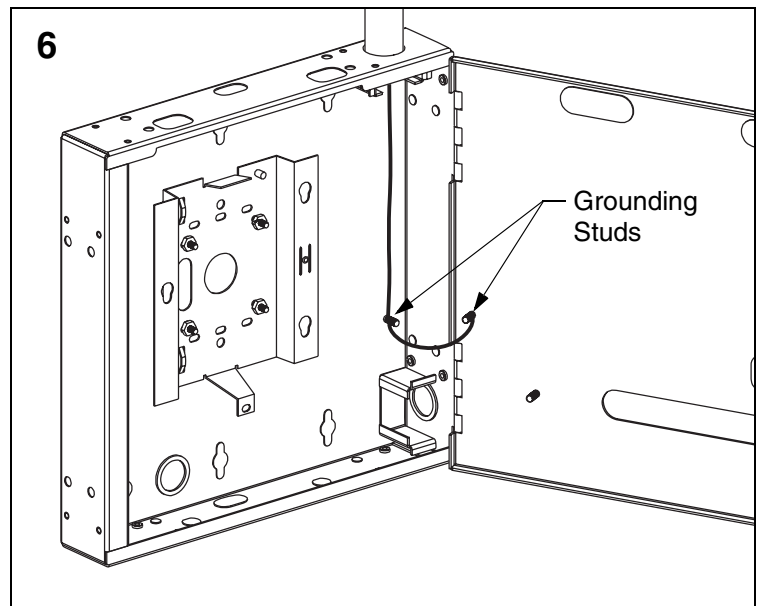

Step 7: Install Wireless Access Point

- 7.1 If 2.4GHz standard dipole antennas will be used, install the antennas on the WAP before it is mounted in the enclosure. Bend the antennas at the pivot point so they are perpendicular to the front surface of the WAP as shown.
- 7.2 If the 802.11a 5GHz paddle type antenna will be used, install the antenna on the WAP before it is mounted in the enclosure.
- 7.3 Insert the three mounting pads, located on the bottom surface of the WAP, into the large portion of the three keyed mounting holes on the bracket.
- 7.4 Pull the WAP downward until an audible “snap” is heard. Lightly pull the WAP in the opposite direction to verify that it is properly locked into place.

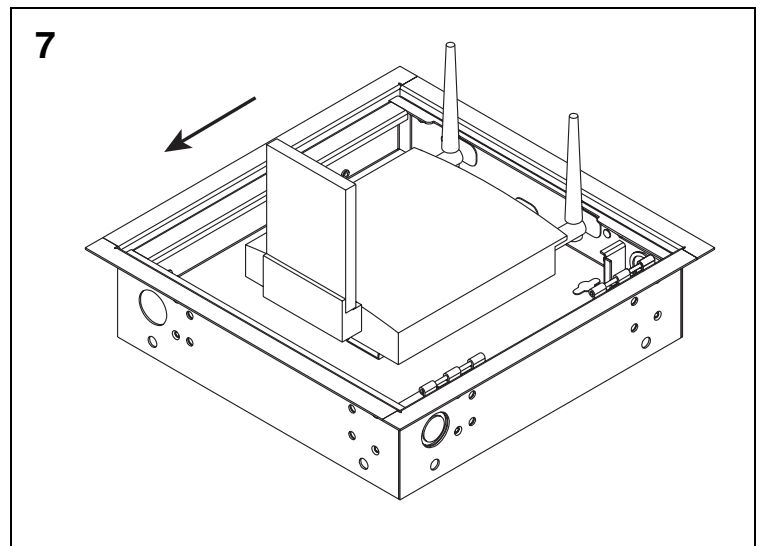

Step 8: Install Surface Mount Box

- 8.1 Route the network cable to and into the enclosure.
Important: When mounting the enclosure in the ceiling, it is recommended that an excess length of network cable be stored outside of the enclosure when conduit is not used. The length of cable placed outside the enclosure above the ceiling should be long enough to allow the enclosure to be removed from the ceiling for maintenance without cutting the network cable from the Cat5e jack that will be installed in the next step. This is necessary because the Cat5e jack cannot be removed through a 1/2" conduit knockout.
- 8.2 Terminate the Cat5e Jack Module to the network cable. Refer to the *PANDUIT* website for jack termination instructions if needed.
- 8.3 Mount the base of the 2 Position Surface Mount Box to the back wall of the enclosure using provided double sided tape.
- 8.4 Snap the terminated jack into position “1” of the box. Place the network cable between the two cable retention tabs on the back of the base.
- 8.5 Remove the breakout tab on the back of the cover.
- 8.6 Snap the cover onto the base.

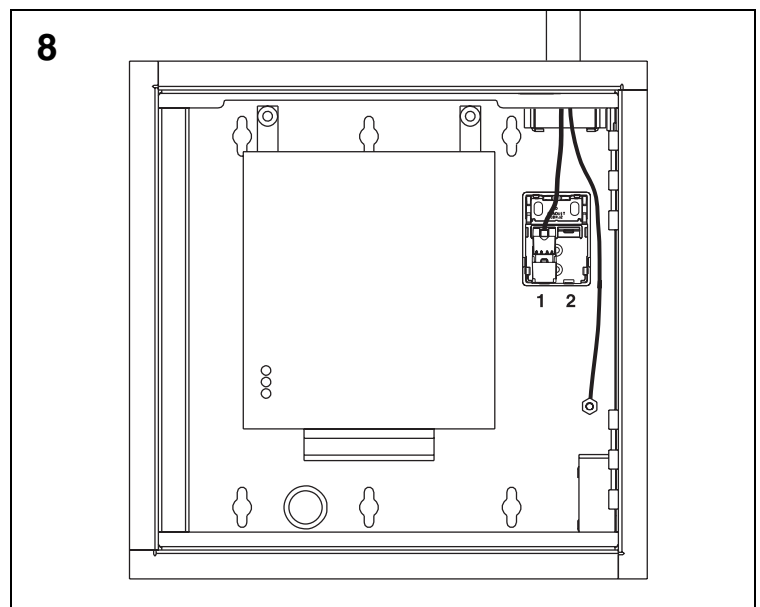

Note: A second Cat5e Jack Module can be installed in position “2” of the surface mount box to provide access to the serial port on the WAP.

Step 9: Install Fire Resistant Foam (if needed)

Note: Fire Resistant Foam used when network cable is routed into the enclosure without the use of conduit in flush wall mount and in-ceiling mount applications.

- 9.1 Place two pieces of fire resistant foam into the foam retention bracket. Both pieces should be underneath the network cable and the ground cable.
- 9.2 Place the remaining two pieces of fire resistant foam on top of the cables.
- 9.3 Press down on the foam and slide the foam retention plate into place. The expanding foam holds the retention plate in place.

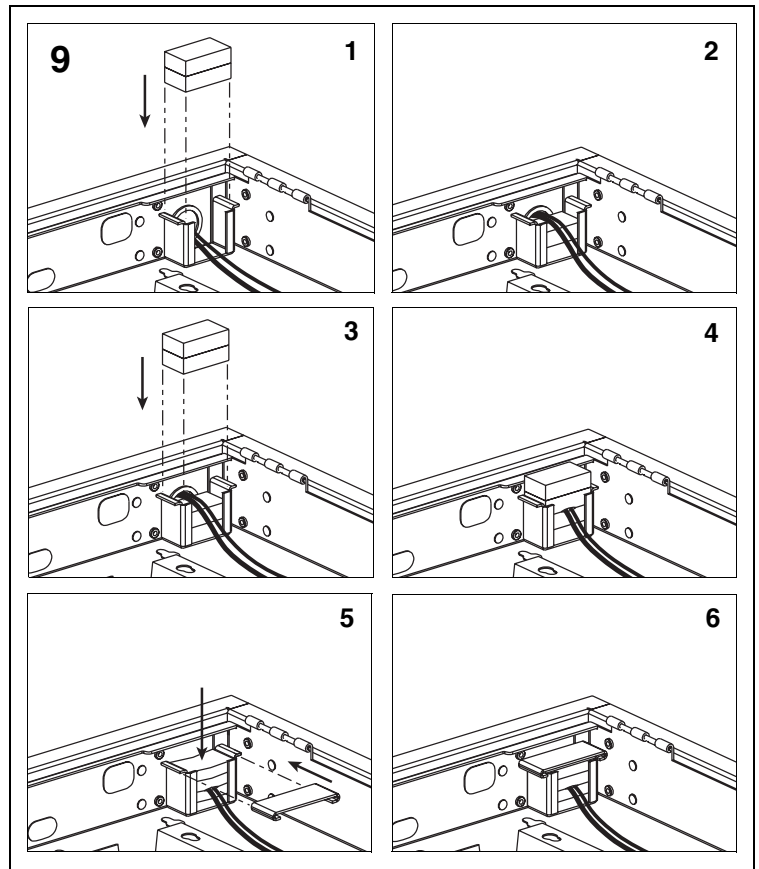

Step 10: Install Patch Cord

- 10.1 Insert one end of the 2' long Cat5 Patch Cord into the RJ45 port located on the WAP.
- 10.2 Insert the other end of the patch cord into the Cat5 jack located in the surface mount box.

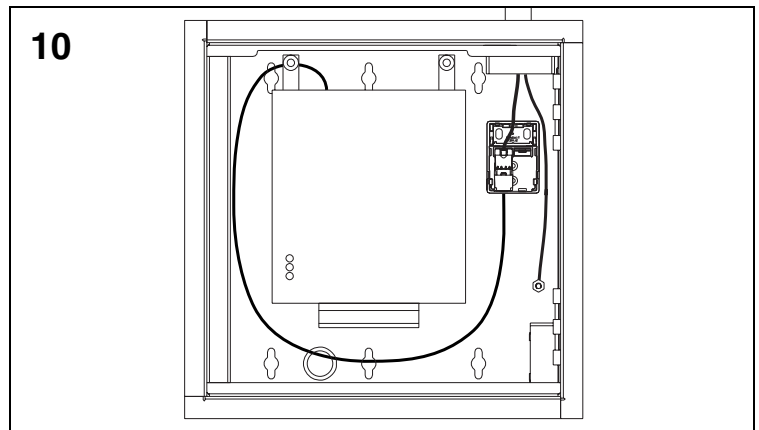

Step 11: Install Slot Cover (if needed)

- 11.1 If the 802.11a 5GHz paddle type antenna is not used, the large slot on the door can be covered using the supplied Slot Cover.
- 11.2 Place the Slot Cover over the two threaded studs and secure with the #10 Split Lock Washers and #10-32 Hex Nuts.

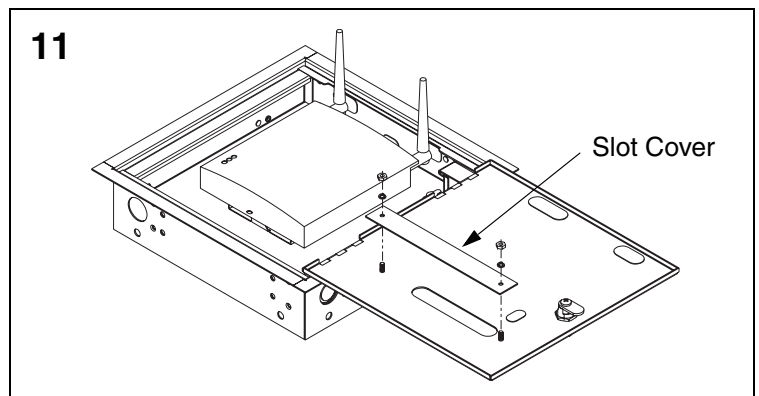

For Instructions in Local Languages
and Technical Support:

www.panduit.com/resources/install_maintain.asp



www.panduit.com

E-mail:
cs@panduit.com

Fax:
(708) 444-6993