

THIS COPY IS PROVIDED ON A RESTRICTED BASIS AND IS NOT TO BE USED IN ANY WAY DETRIMENTAL TO THE INTERESTS OF PANDUIT CORP.

PANDUIT P/N	WEIGHT
SRBCT	.55 LB/EACH PC (249.6 g/EACH PC)

NOTES:

1. SEE CURRENT CATALOG FOR ADDITIONAL PART NUMBER SUFFIXES TO INDICATE COLOR AND OR PACKAGE QUANTITY.
2. SEE CATALOG FOR COMPLETE LIST OF PARTS APPLICABLE FOR USE WITH THIS PART.
3. DIMENSIONS IN PARENTHESES ARE IN METRIC.
4. PART INCLUDES:
 - 1- STRAIN RELIEF BAR
 - 24- CABLE TIE
 - 1- #12-24 SCREW KIT
 - 1- M6 SCREW KIT

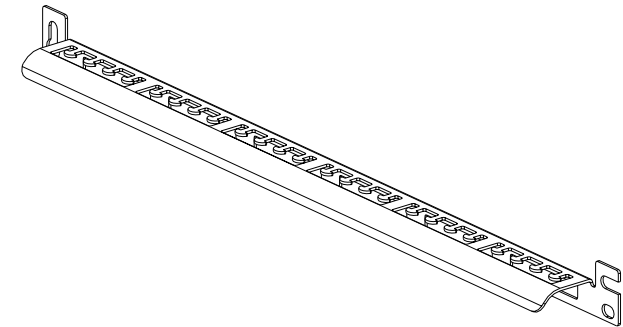
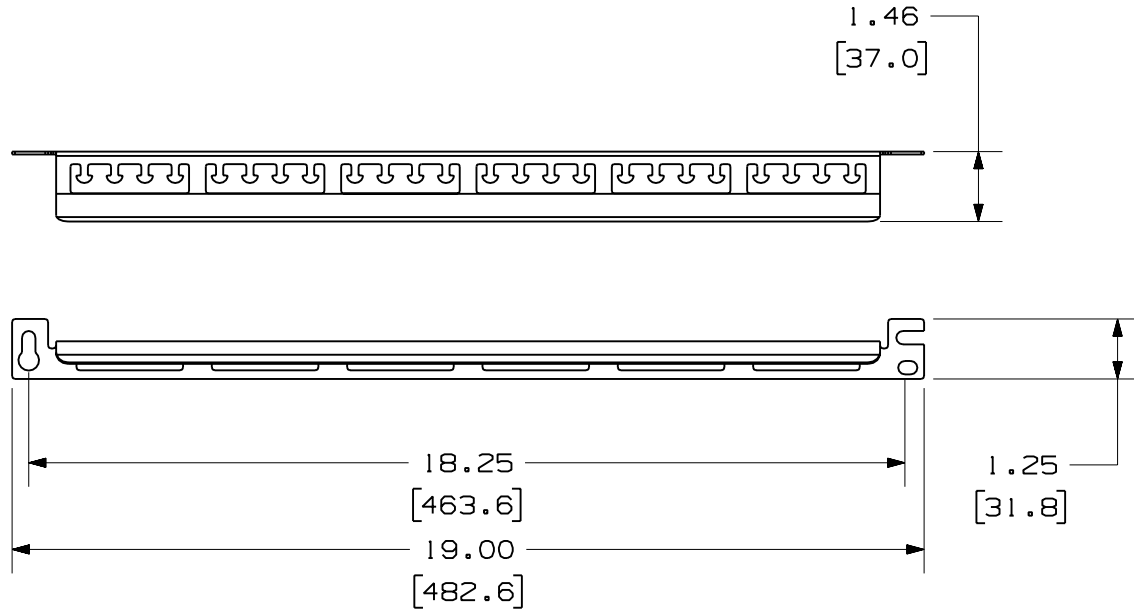

MODEL FILENAME M02077BD_24PORT_STRAIN_RELIEF_00.PRT	SIZE A
DRAWING FILENAME M02077BD_DC_00A.PRT	

STRAIN RELIEF BAR WITH CABLE TIES
CUSTOMER DRAWING

<p>PANDUIT™ CORP. TINLEY PARK, ILL 60477</p>	I.I. NUMBER	N/A
	PRODUCT SPEC	N/A
<p>THIRD ANGLE PROJECTION</p>	WORK INSTRUCTION	N/A
	SCALE	NONE
DRAWN BY JsP	MATERIAL:	PART NO. SRBCT
DATE 3-15-06	STRAIN RELIEF BAR- 16 GAGE C.R.S.	DRAWING NO. 02077-13
CHK'D		

REV	DATE	BY	CHK	DESCRIPTION	ECN	R	CUST	SUP	OTH
R	3-15-06	JsP		RELEASED TO PRODUCTION	02077-13				