

THIS COPY IS PROVIDED ON A RESTRICTED BASIS AND IS NOT TO BE USED IN ANY WAY DETRIMENTAL TO THE INTERESTS OF PANDUIT CORP.

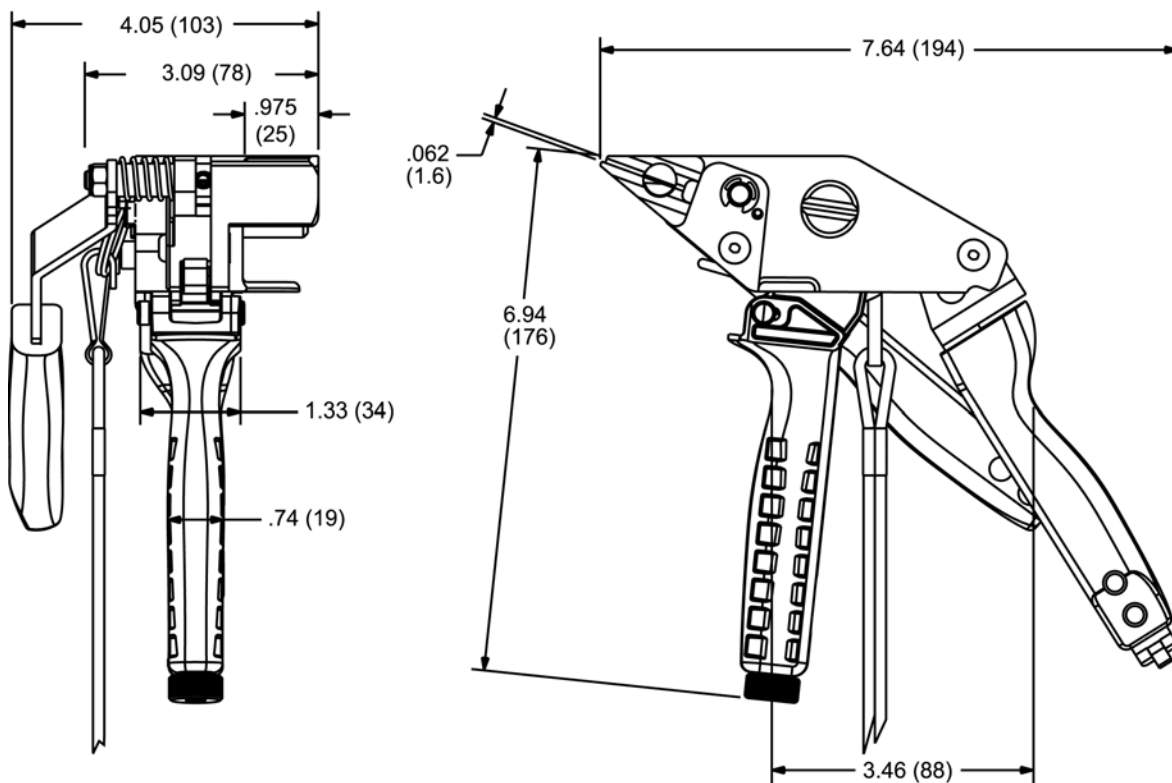

NOTES, UNLESS OTHERWISE SPECIFIED:

PANDUIT Tool Number BT2HT is used to install coated and uncoated PAN-STEEL MS Series strap and buckles in widths of 3/8" (9.5mm), 1/2" (12.7mm); and 5/8" (15.9mm).

THIS TOOLS' FEATURES INCLUDE:

- Single handle trigger for fast installation
- Cable strap side entry for immediate positioning of strap and tool
- Adjustable controlled or Installer controlled tension
- Cut-off capability with the cutter and cutter handle
- Easy removal of excess strap.
- Multi-position rear handle allows access to tight areas.
- Features to release & remove strap from tool before cutting.

CABLE TIE CROSS-SECTION CODE:

MS Series straps and buckles.

TOOL WEIGHT: 2.6 lbs. (41.6 oz.)

Dimensions shown in parenthesis are metric.

F:\wrkgrp\rvusers\ENGR DOCS-NEW\ CUSTDWG/TB25755A01_00 BT2HT.doc

										PANDUIT CORP. TINLEY PARK, ILLINOIS			
										BT2HT CUSTOMER DRAWING			
										UNLESS OTHERWISE SPECIFIED, DIMENSIONAL TOLERANCES ARE:		UNLESS OTHERWISE SPECIFIED, ALL DIMENSIONS ARE GIVEN IN INCHES, THIRD ANGLE PROJECTION.	
										(.x) ± --- (.xxx) ± ---			
										(.xx) ± --- ANGLES ± ---			
										DRAWN BY: BLR		SCALE NONE	
										DATE: 4-28-08		SHEET 1 OF 1	
										CHK'D: BJPU			
00	4-28-08	BLR	BJPU	RELEASED	4288	--	ABJ			DWG A SIZE			
REV	DATE	BY	CHK'D	DESCRIPTION	ECN	-R	CUST	SUP					