

THIS COPY IS PROVIDED ON A RESTRICTED BASIS AND IS NOT TO BE USED IN ANY WAY DETRIMENTAL TO THE INTERESTS OF PANDUIT CORP.

PANDUIT PART NUMBER	MILITARY PART NO. AND CLASS	STUD SIZE	DIMENSIONS in.				
			A ±.03	W ±.01	C ±.02	M ±.03	H ±.01
PN14-4R-3K	MS25036-152 CLASS 2	#4	.76 (19.30)	.25 (6.35)	.22 (5.59)	.65 (16.51)	.12 (3.05)
PN14-6R-3K	MS25036-107 CLASS 2	#6	.86 (21.84)	.31 (7.87)	.25 (6.35)	.70 (17.78)	.15 (3.81)
PN14-6RN-3K	MS25036-106 CLASS 2	#6	.76 (19.30)	.25 (6.35)	.22 (5.59)	.65 (16.51)	.15 (3.81)
PN14-8R-3K	MS25036-153 CLASS 2	#8	.86 (21.84)	.31 (7.87)	.25 (6.35)	.70 (17.78)	.17 (4.32)
PN14-10R-3K	MS25036-108 CLASS 2	#10	.86 (21.84)	.31 (7.87)	.25 (6.35)	.70 (17.78)	.20 (5.08)
PN14-14R-3K	MS25036-154 CLASS 2	1/4"	1.06 (26.92)	.44 (11.18)	.38 (9.65)	.83 (21.08)	.27 (6.86)

NOTES:

- UL LISTED AND CSA CERTIFIED FOR:
 - A. 600V. MAX. VOLTAGE RATING
 - B. 221°F. (105°C) MAX. TEMP. RATING
 - C. #16-14 (1.5-2.5mm² AWG SOLID OR STRANDED COPPER WIRE
- MATERIAL:
 - A. STAMPING- .03" (.8) THK. COPPER, TIN PLATED
 - B. HOUSING- NYLON, BLUE
 - C. SLEEVE- BRASS, TIN PLATED
- WIRE STRIP LENGTH- 1/4" +1/32, -0 (6.4, +.8, -0)
- PACKAGE QUANTITY: 3K = 3000 PCS.
- DIMENSIONS IN PARENTHESIS ARE IN MILLIMETERS
- INSTALLATION TOOLS:
 - A. PRESSES - CP-851, CP-860, CP-861, CP-871
 - B. APPLICATOR - CA-800, CA9
 - C. DIE INSERTS - CD-800-2, CD9-2A,B

Panduit part numbers shown on this drawing meet the material requirements of RoHS (EUROPEAN DIRECTIVES 2002/95/EC) as proposed by the Technical Adaptation Committee

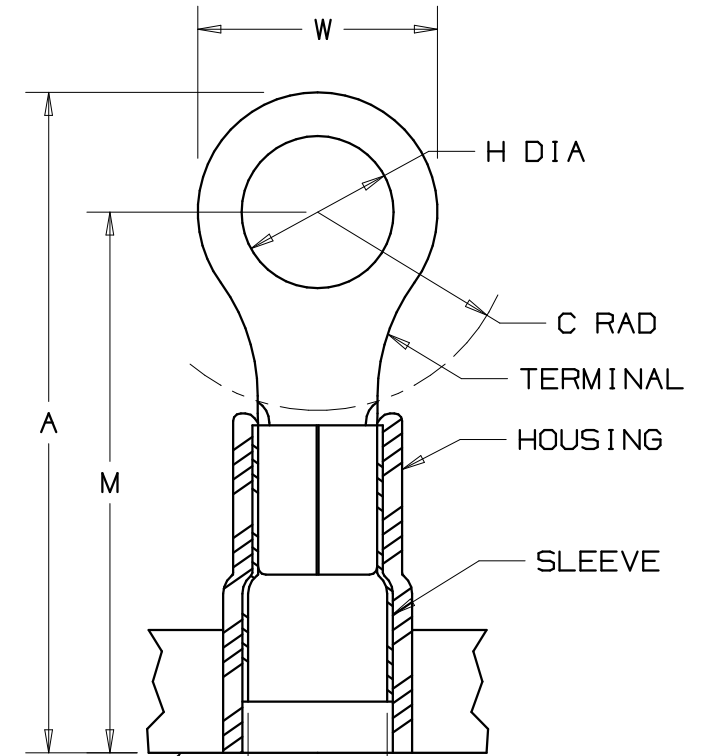

LISTED
587H
E52164



CERTIFIED
LR31212

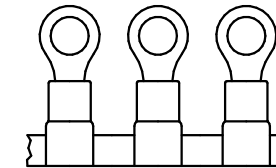

.162 (4.11)
MAX WIRE
INSUL DIA
.080 (2.03)
MIN WIRE
INSUL DIA.

06	8/06	DAW	DAW	ADDED MILITARY PART NO. & CLASS	TR00155	LCA	TRO
05	12/00	ED	SKB	FILESPEC WAS: N41099AA_PCD_04	08925	JAC	CCH
04	11/96	JB		ADDED DIM".080(2.03) MIN WIRE DIA."	05414		
03	3/96	JKD	RLS	REVISED DIMS, ADDED NOTE 6	04259	TJP	TJP
02	12/89	FS	LA	"W" FOR PN14-14R WAS .44		LA	DBH
REV	DATE	BY	CHK	DESCRIPTION	ECN	CUST	PM

A41099_06

PANDUIT CORP.

TINLEY PARK, ILLINOIS

TERMO 3PC. CONTINUOUSLY MOLDED NYLON INSULATED, 16-14 BARREL, RINGS

DRAWN BY JMV CHK'D LA SCALE NONE DRAWING NO. A41099