

THIS COPY IS PROVIDED ON A RESTRICTED BASIS AND IS NOT TO BE USED IN ANY WAY DETRIMENTAL TO THE INTERESTS OF PANDUIT CORP.

PART NUMBER	MATERIAL	"A" HEIGHT +/- .062	IMPRINT AREA "B" +/- .062	VERTICAL REPEAT "C" +/- .062	LABELS PER ROW	STANDARD PKG. QTY.
S200X150TAT	GMT1	1.50 [12.7]	0.50 [12.7]	1.75 [44.5]	2	5000
S200X250TAT		2.50 [63.5]	1.00 [25.4]	2.75 [69.8]		1000
S200X150VATY	GMV16 OR GMV17	1.50 [12.7]	0.50 [12.7]	1.75 [44.5]		5000
S200X225VATY		2.25 [57.2]	0.75 [19.1]	2.50 [63.5]		1000
S200X250VATY		2.50 [63.5]	1.00 [25.4]	2.75 [69.8]		
S200X400VATY		4.00 [101.6]		4.25 [108.0]		
S200X650VATY		6.50 [165.1]	1.50 [38.1] +/- .10	6.75 [171.5]		

NOTES:  
1. MILLIMETERS ARE IN [ ].

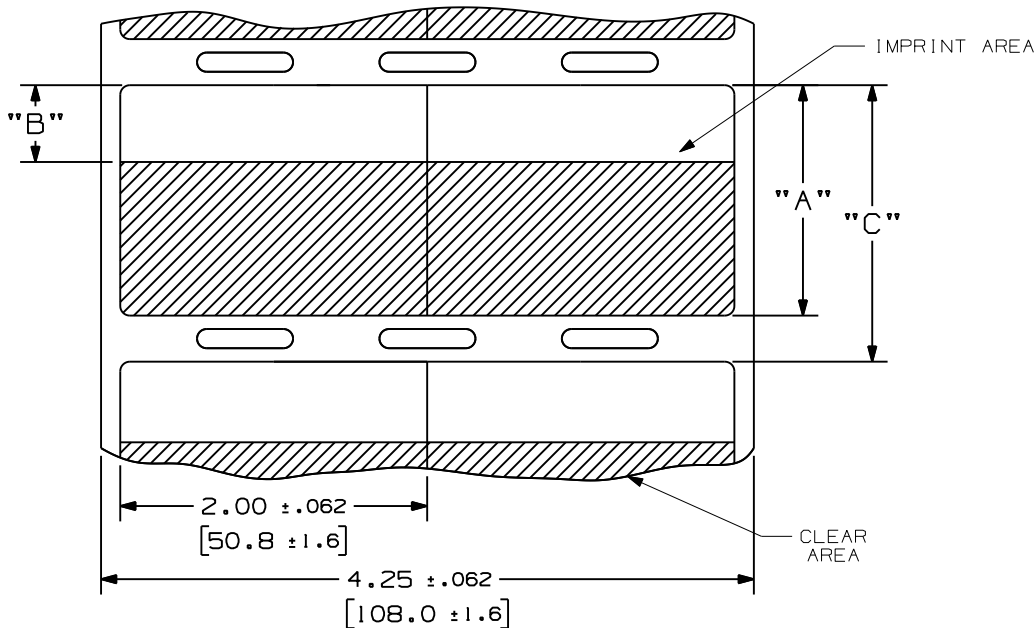

CAD FILENAME/LAYERS  
I00472BY\_DC\_C10468/08H

REV	DATE	BY	CHK	DESCRIPTION	ECN	R	CUST	SUP
7	10/25/11	RVU		"GMV16 OR GMV17" WAS "GMV".	6548	R		
6	12/10/09	RVU	MSAD	UPDATE ON ALL STANDARD TOLERANCES. ADD +/- .10 TO 1.50.	5925	R		
5	3/5/09	RVU		5000 WAS 1000. +/- .062 UPDATE. This change was originally initiated and approved under ECN 5371 but the drawing change was not properly implemented.	5698	R		
4				VOID				
3	1-6-09	RVU		1.50 +/- .10 WAS 1.00 +/- .031. CHANGE SIZE B TO A. .12, .062, .020 WAS .030, .015, .010. REMOVE NOTE 2. REMOVE ALL VAT PARTS. ADD NEW P/N, S200X150TAT, S200X250TAT, AND S200X250VATY. S200X***VATY, GMV16 WAS GMV.	5633	R		
2	5/30/07	RVU			5021	R		
1	1-8-07	RVU		REVISED TOLERANCES.	4830	R		
0	9-1-06	RVU		DRAWING RELEASED.	4671	R		

PANDUIT CORP. TINLEY PARK, ILLINOIS

CUSTOMER DRAWING  
OPTIMUM SELF-LAM. S200X\*\*\*VATY  
THERMAL TRANSFER PRINTABLE LABELS

UNLESS OTHERWISE SPECIFIED,  
DIMENSIONAL TOLERANCES ARE:  
(.X) ± .12 (.XXX) ± .025  
(.XX) ± .062 ANGLES ±

UNLESS OTHERWISE SPECIFIED,  
ALL DIMENSIONS ARE GIVEN  
IN INCHES, THIRD ANGLE PROJECTION.

DRAWN BY  
RVU

MAT'L:

SCALE  
NTS

DATE  
9-1-06

SEE TABLE

DRAWING NO.

C10468

DWG  
A  
SIZE

CHK'D  
*[Signature]*