



# Quadruple Patch Panel Density

Maximize Floor Space

Reduce Real Estate Costs



**THE ULTIMATE HIGH DENSITY CABLE MANAGEMENT SOLUTION**  
for Data Centers and Telecommunications Rooms



# The Ultimate Cable Management Solution for Data Centers and Telecommunications Rooms

Designed to reduce real estate costs, maximize network reliability and provide flexible system design, *MINI-COM*® Angled Modular Patch Panels and *PATCHRUNNER*™ Vertical Cable Managers deliver a complete solution for data centers and telecommunications rooms.

## Solution Benefits

**Reduce real estate costs** with innovative patented angled modular patch panels and space saving vertical cable managers. These products work together to provide up to quadruple the density reducing costs in data centers and telecommunications rooms.

- Angled high density modular patch panels provide 48 ports in one rack space
- Bend radius fingers on vertical cable managers eliminate the need for horizontal cable managers

**Ensure network reliability** with a complete solution that protects cables from strain, maintains data integrity and delivers reliable network performance.

- Angled modular patch panel design promotes proper bend radius of patch cords as they are routed into the vertical pathway
- Bend radius fingers on vertical cable managers support the cables as they transition to the vertical pathway to ensure data integrity

**Achieve flexible system design** with angled modular patch panels and adaptable vertical cable managers.

- Modular patch panels accept *MINI-COM*® Copper, Fiber and Coax Modules providing complete modularity for mixed media applications and future upgrades
- Slack management spools on vertical cable managers can be repositioned to organize and manage cables providing maximum design flexibility
- Inter-rack pathways can be positioned at the top and/or bottom of the rack minimizing the need to route cables under the floor or overhead

**PATENTED**  
ANGLED PATCH PANEL



**Maximum Density**  
Minimum Floor Space

# PANDUIT Cable Management Solutions

## Standard vs. High Density

To illustrate the type of savings that can be achieved, in a 960 port application, a comparison of a standard vs. high density cable management solution demonstrates a more efficient use of space and the cost savings realized.

### Reduce System Layout Width by 36%

Standard Layout	Qty.	Width	
		In.	mm
CMR19X84 standard EIA channel racks	4	20.31	515.8
WMPV45 vertical managers	2	4.24	107.7
WMPVHC45 vertical managers	3	5.87	149.1
WMPVCB center mounting kits	3	N/A	
WMPH2E horizontal managers	20	N/A	
CPP48WBL 48 port modular patch panels	20	N/A	
<b>Total (not including jack modules)</b>	<b>52</b>	<b>107.3</b>	<b>2725.9</b>

High Density Layout	Qty.	Width	
		In.	mm
CMR19X84 standard EIA channel racks	2	20.31	515.8
PRV12 vertical managers	1	12	304.8
PRV8 vertical managers	2	8	203.2
PRD12 hinged doors	1	N/A	
PRD8 hinged doors	2	N/A	
CPPLA48WBL 48 port angled modular patch panels	20	N/A	
<b>Total (not including jack modules)</b>	<b>28</b>	<b>68.6</b>	<b>1742.4</b>

#### Standard Footprint\*

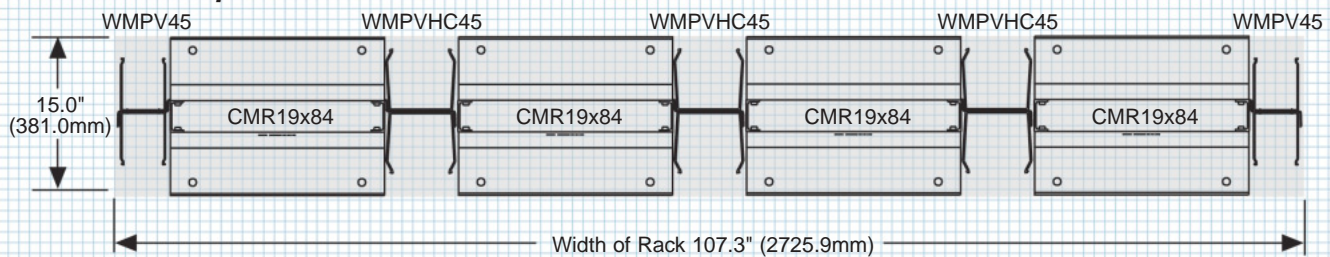

#### High Density Footprint\*

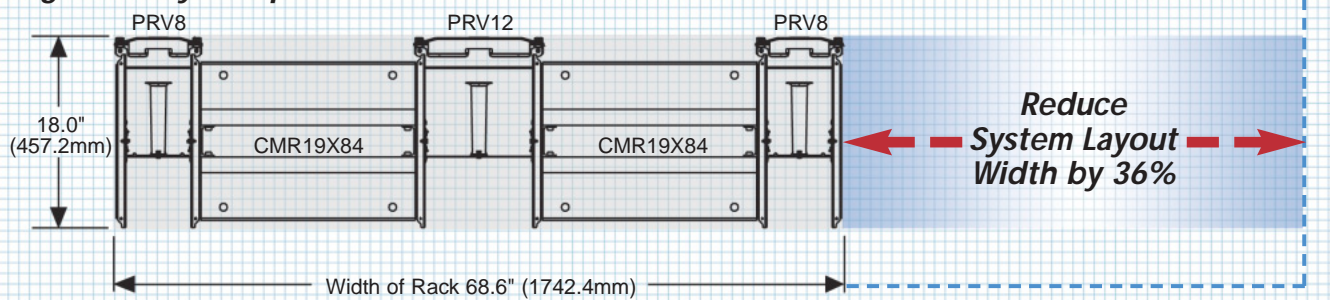

### Reduce Square Footage and Real Estate Costs Up to 23%

	Standard	High Density	Benefits
<b>Number of parts</b>	52	28	<b>Reduce installation time with 46% fewer system components to manage</b>
<b>Layout width</b>	107.3" (2725.9mm)	68.6" (1742.4mm)	<b>36% narrower profile is ideal for space constrained applications</b>
<b>Square footage</b>	11.2 ft <sup>2</sup> (1.04M <sup>2</sup> )	8.6 ft <sup>2</sup> (0.80M <sup>2</sup> )	<b>Smaller footprint saves 23% floor space</b>
<b>Real estate cost**</b>	\$4,480	\$3,440	<b>Resulting space savings reduces real estate costs 23%</b>

\*Representative application, actual configurations may vary.

\*\*Based on \$400/ft<sup>2</sup> annually.



# PANDUIT Cable Management System Roadmap

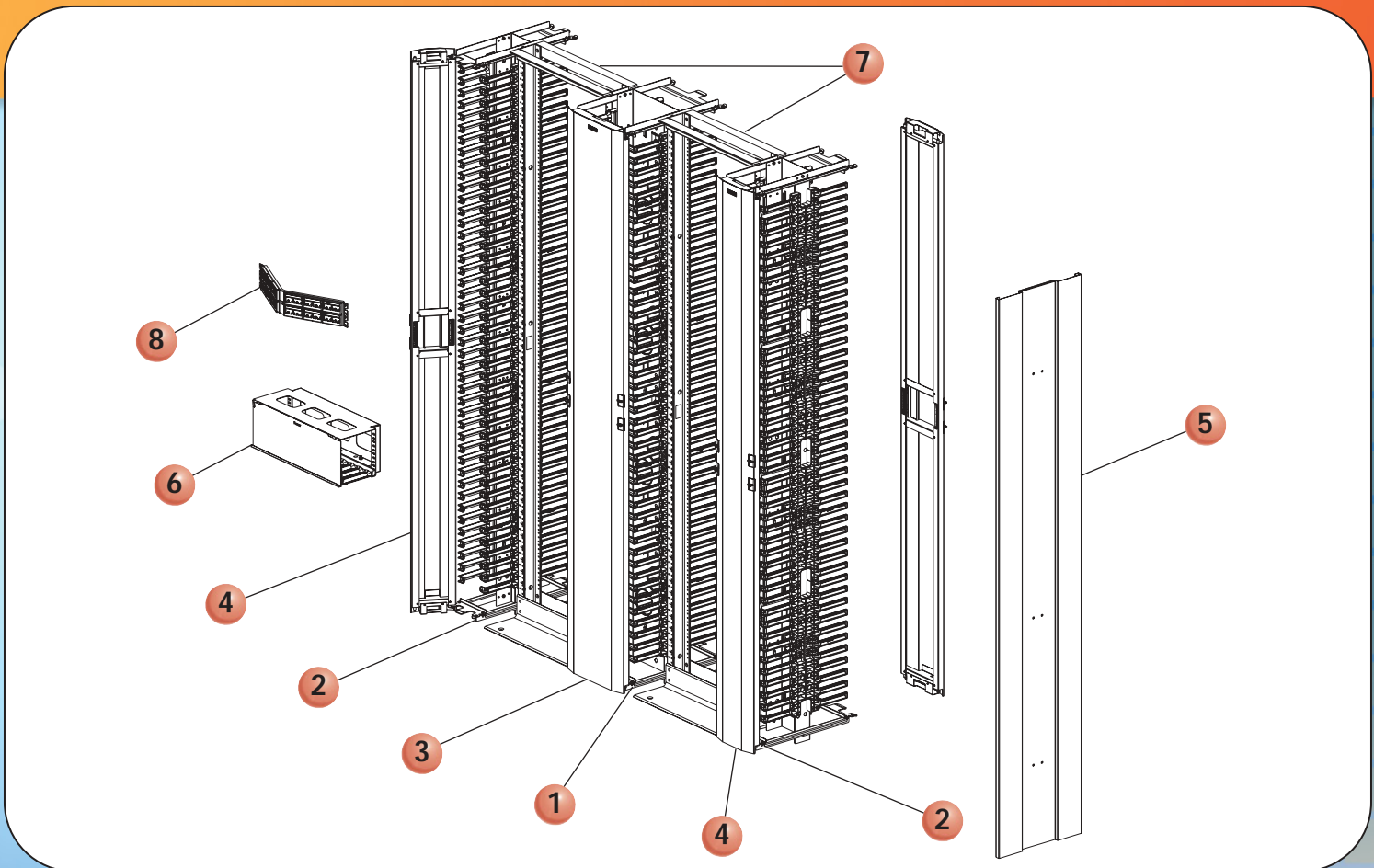

Ref. No.	Part Number	Description
<i>Vertical Managers</i>		
1	PRV12	Vertical manager, 12"W x 7"H, front and rear
2	PRV8	Vertical manager, 8"W x 7"H, front and rear
	PRV6	Vertical manager, 6"W x 7"H, front and rear
	PRVF12	Vertical manager, 12"W x 7"H, front only
	PRVF8	Vertical manager, 8"W x 7"H, front only
	PRVF6	Vertical manager, 6"W x 7"H, front only
<i>Hinged Doors</i>		
3	PRD12	Dual hinged door, 12"W, front or rear
4	PRD8	Dual hinged door, 8"W, front or rear
	PRD6	Dual hinged door, 6"W, front or rear

One RU = 1.75" (44.45mm).  
All product color is black.

Ref. No.	Part Number	Description
<i>Accessories</i>		
5	PREP	End panel
6	NCMHAEF4	Horizontal manager pathway, 4 RU
	NCMHAEF2	Horizontal manager pathway, 2 RU
<i>EIA Rack</i>		
7	CMR19X84	19"W x 7"H standard EIA rack, 45 RU
<i>Angled Patch Panels</i>		
	CPPA48HDWBL	Angled patch panel, 48 port, high density, 1 RU
	CPPLA24WBL	Angled patch panel, 24 port, 1 RU
8	CPPLA48WBL	Angled patch panel, 48 port, 2 RU
	CPPA24FMWBL	Angled patch panel, 24 port, flush mount 1 RU
	CPPA48FMWBL	Angled patch panel, 48 port, flush mount 2 RU
	CPPA72FMWBL	Angled patch panel, 72 port, flush mount 2 RU

## WORLDWIDE SUBSIDIARIES AND SALES OFFICES

PANDUIT CANADA  
Markham, Ontario  
cs-cdn@panduit.com  
Phone: 800.777.3300

PANDUIT EUROPE LTD.  
London, UK  
cs-emea@panduit.com  
Phone: 44.20.8601.7200

PANDUIT SINGAPORE PTE. LTD.  
Republic of Singapore  
cs-ap@panduit.com  
Phone: 65.6379.6700

PANDUIT JAPAN  
Tokyo, Japan  
cs-japan@panduit.com  
Phone: 81.3.3767.7011

PANDUIT LATIN AMERICA  
Jalisco, Mexico  
cs-la@panduit.com  
Phone: 52.333.666.2501

PANDUIT AUSTRALIA PTY. LTD.  
Victoria, Australia  
cs-aus@panduit.com  
Phone: 61.3.9794.9020

For a copy of PANDUIT product warranties, log on to [www.panduit.com/warranty](http://www.panduit.com/warranty)



For more information  
Visit us at [www.panduit.com](http://www.panduit.com)  
Contact Customer Service by email: [cs@panduit.com](mailto:cs@panduit.com)  
or by phone: 800-777-3300

© 2005 PANDUIT Corp.  
ALL RIGHTS RESERVED  
Printed in the U.S.A.  
WW-RKCB03  
5/2005