

# OWNER'S INSTRUCTION MANUAL



**TRENDLINE™**

**MODEL 8150 TELEPHONE  
WITH VOLUME CONTROL**

**CORTELCO**

# TRENDLINE™

---

## MODEL 8150 TELEPHONE

• Desk/Wall Mountable • Dial Light • Tone/  
Pulse Switchable Dialing • FLASH • Last Num-  
ber Redial • MUTE • RESET • Ringer Volume  
Control • Hearing-Aid Compatible

**THANK YOU**  
**FOR PURCHASING THIS TELEPHONE**

**Your new telephone** was made  
by people who take a great deal  
of PRIDE in producing quality  
products to assure you years of  
trouble-free service.



**We want you to know all about your new telephone**, how to install it, the features it provides, and the services you can expect from its use. We have included this information in your Owner's Instruction Manual.

**PLEASE READ BEFORE INSTALLING  
AND USING YOUR NEW TELEPHONE.**

# CORTELCO

# Table Of Contents

<b>Important Safety Instructions .....</b>	<b>2</b>
<b>Features Of Your Telephone .....</b>	<b>4</b>
<b>Installing Your Telephone .....</b>	<b>6</b>
Unpacking Your Telephone .....	6
Modular Wall Jacks .....	6
Desk Installation .....	7
Wall Installation .....	7
Position The Cradle Tab .....	8
Check For Dial Tone .....	8
Directory Card .....	8
<b>Before Using Your Telephone .....</b>	<b>9</b>
<b>Maintenance Information .....</b>	<b>9</b>
<b>Telephone Service Problems .....</b>	<b>10</b>
No Dial Tone .....	10
Dial Tone But No Ringing .....	10
Dial Tone But No Dialing .....	10
<b>Repair of Your Telephone .....</b>	<b>11</b>
<b>The FCC Wants You To Know .....</b>	<b>12</b>

# IMPORTANT SAFETY INSTRUCTIONS

**Always follow basic safety precautions** when using your telephone equipment to reduce the risk of fire, electrical shock, and injury.

1. Read and understand all instructions.
2. Follow all warnings and instructions marked on the product.
3. Unplug this product from the wall outlet before cleaning. Use a damp cloth for cleaning. Do not use liquid or aerosol cleaners.
4. Do not use the telephone near water. For example, do not use near a bathtub, wash bowl, kitchen sink, laundry tub, swimming pool, or in a wet basement.
5. Do not place this product on an unstable cart, stand or table. The product may fall causing serious damage to the product.
6. Use only the type power source indicated on the label. If you are not sure of the type of power supply to your home, consult your dealer or local power company.
7. Do not place any objects on the telephone line cord. Do not locate this product where the line cord will be walked on.
8. Do not block or cover ventilation slots and openings in the bottom of the telephone. Never spill liquid on the telephone or push objects of any kind through ventilation slots. Liquid or objects may touch dangerous voltage points or short out parts that could result in a risk of fire or electrical shock.
9. To reduce the risk of electric shock, do not disassemble this product, but take it to a qualified serviceman when service or

repair work is required. Opening or removing covers may expose you to dangerous voltage or other risks. Incorrect reassembly can cause electrical shock when the appliance is subsequently used.

10. Unplug this product from the wall outlet and refer servicing to qualified service personnel under the following conditions:
  - a. When the line cord is frayed or plugs damaged.
  - b. If liquid has been spilled into the telephone.
  - c. If the telephone has been exposed to rain or water.
  - d. If the product does not operate properly by following the operating instructions. (Adjust only those controls, that are covered by the operating instructions because improper adjustment of other controls may result in damage and will often require extensive work by a qualified technician to restore the product to normal operation.)
  - e. If the telephone has been dropped or the cabinet damaged.
  - f. If the telephone exhibits distinct change in performance.
11. Avoid using a telephone (other than a cordless type) during an electrical storm. There may be a remote risk of electrical shock from lightning.
12. Do not overload wall outlets and extension cords as this can result in the risk of fire or electrical shock.
13. Do not use a telephone to report a gas leak in the vicinity of the leak.

**SAVE THESE INSTRUCTIONS**

# FEATURES OF YOUR TELEPHONE

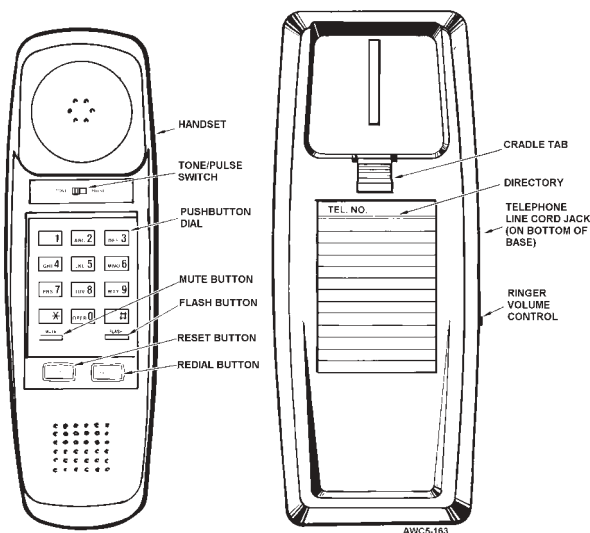

**Hearing-Aid Compatible Handset** The handset on your Trendline telephone is equipped with a TONE/PULSE switch, a lighted dial, MUTE, FLASH, RESET AND REDIAL buttons, and a receiver that works with magnetically-coupled hearing aids.

**TONE/PULSE Switch** The TONE/PULSE switch is used to set the type of dialing for your telephone to match the local service from your telephone company. The PULSE position is for Pulse dialing service. The TONE position is for Tone dialing service. (Some telephone companies cannot accept Tone dialing.)

**Pushbutton Dial** The pushbutton dial is used to dial numbers using either pulse or tone dialing. The dial light is on when you lift the handset.

**MUTE Button** You can press and hold the MUTE button so that the other party cannot hear the conversation at your telephone. You can continue to listen to the other party.

**FLASH Button** The FLASH button sends an interrupt signal to the distant office. The interrupt is a 600-millisecond, timed line disconnect which tells the distant office that you wish to use an available feature. The results of a FLASH signal will depend on the services you have available.

**RESET Button** Use the RESET button to disconnect a call and receive dial tone for making another call. The line remains disconnected for as long as you press the RESET button.

# FEATURES OF YOUR TELEPHONE

**REDIAL Button** Your Trendline telephone stores in memory the last number dialed (32 digits maximum). You can dial the stored number by lifting the handset and pressing the REDIAL button.

**You can erase the number stored in memory** by lifting the handset and dialing any digit.

**Cradle Tab** The cradle tab can be positioned for desk installation of the telephone base, or to hold the handset in place for wall installation.

**Directory** Use the directory on the telephone base to record emergency and frequently-called numbers.

**Telephone Line Cord Jack** Connect the modular line cord supplied with your telephone at this jack: long cord for desk installation; short cord for wall installation.

**Ringer Volume Control** The 3-position switch (located on the side of the telephone base) is used to set ringer volume. You can select high volume (HI), low volume (LO), or you can silence the ringer (OFF).

**Receiver Volume Control** can be adjusted by use of thumb wheel, on back of handset, to achieve an acceptable sound level for the hearing impaired user.

# INSTALLING YOUR TELEPHONE

## UNPACKING YOUR TELEPHONE

**Check the contents of the carton.** Make sure you have a telephone, a 12-foot handset cord, a long modular line cord, and a short modular line cord.

**If anything is missing or damaged,** contact the place of purchase.

## MODULAR JACKS

**To install your telephone,** you must have a modular wall jack at the desired location, or a 4-prong jack that can be modified with a 4-prong adapter. If your telephone line does not have a modular wall jack, or a jack that can be modified, you must have one installed.

***DANGER: To reduce the risk of electrical shock and personal injury, observe the following when installing station wiring:***

- 1. Never install telephone wiring during a lightning storm.***
- 2. Never install telephone jacks in wet locations unless the jack is specifically designed for wet locations.***
- 3. Never touch uninsulated telephone wires or terminals unless the telephone line has been disconnected at the network interface.***
- 4. Use caution when installing or modifying telephone lines.***

Various types of modular wall jacks are shown to the right. The USOC RJ11C modular wall jack is for desk telephones and the USOC RJ11W modular wall jack is for modular wall telephones.

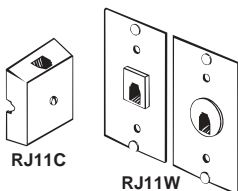

Various types of 4-prong wall jacks are shown to the right along with a 4-prong adapter. The 4-prong adapter plugs into the wall jack for modular wall jack service.

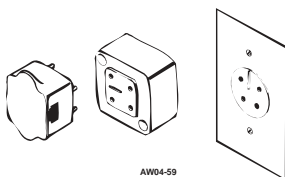



# INSTALLING YOUR TELEPHONE

## DESK INSTALLATION

To install as a desk telephone, use the long modular line cord provided and refer to the diagram.

- On the bottom of the telephone base, locate the modular jack inside the cavity. Plug one end of the line cord into the jack.
- Route the cord as shown through the channel to the back of the telephone base.

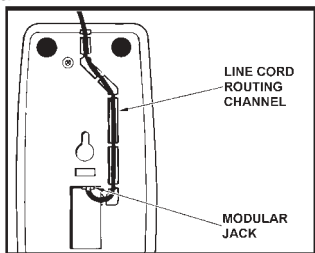

AWC90-309A

- Plug the unattached end of the line cord into the modular wall jack.

## WALL INSTALLATION

To install a wall telephone, use the short modular line cord provided and refer to the diagram.

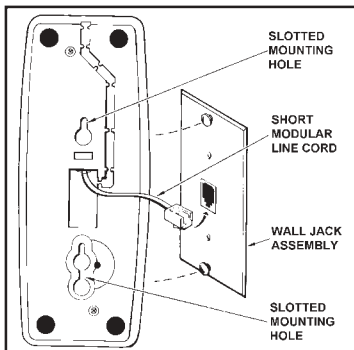

AWC90-309B

- On the bottom of the telephone base, locate the modular jack inside the cavity. Plug one end of the short line cord into the jack.
- While holding the telephone base close to the mounting location, plug the unattached end of the line cord into the modular wall jack. Excess line cord must be folded into the cavity.
- Note the two mounting studs on the modular wall jack. Align the telephone so that the two mounting studs are inserted into the two slotted holes in the telephone base. Slide the telephone down until it is tightly seated.

# INSTALLING YOUR TELEPHONE

## POSITION THE CRADLE TAB

To position the cradle tab for the type of installation desired, refer to the diagram.

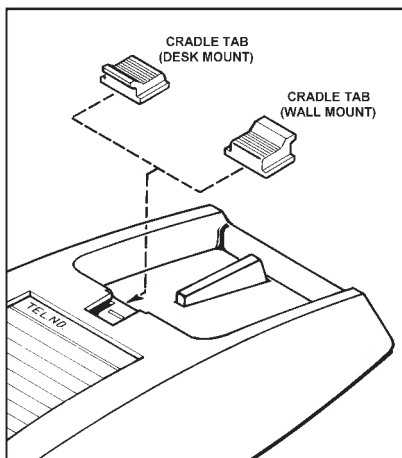

- Apply upward pressure on the serrated area to loosen and remove the cradle tab.
- Rotate the cradle tab for the desired position. The tab should be up for hanging the handset in a wall installation or down for a desk installation.
- Apply downward pressure on the serrated area to lock the cradle tab in place.

## CHECK FOR DIAL TONE

Lift the handset and listen for dial tone.

- **When you hear dial tone**, your telephone is ready to use.
- **If you do not hear dial tone**, refer to the Telephone Service Problems part of your manual.

## DIRECTORY CARD

Remove the clear plastic cover from the directory card tray, and remove the card. Record your frequently called and emergency telephone numbers. Place the card into the tray and reinstall the plastic cover.

# BEFORE USING YOUR TELEPHONE

1. **Set the ringer volume control.** If the control is set to OFF, you will not hear the ringer when someone calls you.
2. **Your telephone has a TONE-PULSE switch.** Set the switch to match the dialing service from the telephone company.
  - **If you have pulse service,** set the Tone-Pulse switch to PULSE.
  - **If you set the switch for TONE service,** you must have TONE service or you cannot dial.
  - **If you set the switch for PULSE service and you have TONE service,** you can dial numbers, but you cannot use distant services, such as bank-by-phone, which require TONE signals.
  - **If you have PULSE service and your telephone has a TONE-PULSE switch,** you can set the switch to PULSE and dial a distant service and then set the switch to TONE to use the service. **BE SURE TO SET THE SWITCH TO PULSE WHEN YOU FINISH THE CALL.**

## MAINTENANCE INFORMATION

**Treat your telephone with care** for trouble-free performance. Avoid dropping the handset. Carefully place the handset on-hook after use.

**Clean your telephone with a damp cloth.** Stains may be removed with a mild soap. Do not use liquid or aerosol detergents or cleaning agents.

# TELEPHONE SERVICE PROBLEMS

**If you have any problems with your telephone service,** determine if the problem is with your telephone or the telephone company lines. **BEFORE CALLING THE TELEPHONE COMPANY,** be aware that they may charge you for a service call if the problem is caused by your telephone.

## **NO DIAL TONE**

- Unplug your telephone from the wall jack. Plug a substitute telephone that is known to work properly into the same wall jack.
- If the problem persists when using the substitute telephone, notify the telephone company.
- If the substitute telephone works properly, you must have your telephone repaired before reconnecting it to the wall jack.

## **DIAL TONE BUT NO RINGING**

- Check that the RINGER VOLUME CONTROL is not set to OFF.
- Set the RINGER VOLUME CONTROL to HIGH and have someone on another line call you. Before answering the call, set the RINGER VOLUME CONTROL to the desired volume.

## **DIAL TONE BUT NO DIALING**

- Set the TONE/PULSE switch. You cannot dial out in TONE position if you have Rotary Dial Service.
- For Rotary Dial Service, set the switch to PULSE position.
- For Tone Dial Service, set the switch to TONE position.
- Try both positions if you are not sure.

# REPAIR OF YOUR TELEPHONE

**DO NOT ATTEMPT TO REPAIR THE TELEPHONE YOURSELF.** Telephones manufactured by Cortelco must be returned to us for repair.

**You can return your telephone to Cortelco** for repair or replacement in accordance with our LIMITED WARRANTY.

**DATE-OF-PURCHASE** Cortelco warrants telephones against defects in material and workmanship in accordance with our LIMITED WARRANTY. If your telephone is returned for repair, include a copy of your sales receipt containing the date-of-purchase. **DO NOT INCLUDE THE ORIGINAL SALES RECEIPT.**

**If date-of-purchase is not included,** the factory date printed on the label on the bottom of your telephone will be used as the date-of-purchase. The factory date allows six months for distribution and sale of the telephone.

**If you return your telephone for repair,** the warranty period is not extended. The original date-of-purchase continues to apply to your warranty.

**OUT-OF-WARRANTY REPAIR** We will repair this telephone for a nominal fee after the LIMITED WARRANTY has expired if you send it to us in a complete and undamaged condition. The repaired telephone will be shipped to you C.O.D., freight collect.

**FOREIGN ATTACHMENTS** Remove all attached devices, such as adapter plugs or long cords, from your telephone before returning for repair. We do not assume responsibility for repair or return of attachments. Check our LIMITED WARRANTY.

**RETURN-FOR-REPAIR PACKAGING** If you are returning a telephone to us for repair, package it carefully, preferably in the original carton. Be sure to include your return address, a copy of the sales receipt showing date-of-purchase, and a note describing the problem you have with your telephone. Shipping must be prepaid. If the telephone is in warranty, it will be repaired or replaced, at our option, at no cost to you, and it will be returned shipping prepaid.

Ship telephones (shipping prepaid) to:

Cortelco  
REPAIRCENTER  
1703 SAWYER ROAD  
CORINTH, MS 38834

# THE FCC WANTS YOU TO KNOW

**DESIGN COMPLIANCE** Your telephone is designed to comply with FCC Rules and Regulations, Part 68. It can be connected to the telephone network as FCC-registered terminal equipment. The registration number is printed on the label on the bottom of your telephone.

**NOTIFICATION TO THE TELEPHONE COMPANY** As a customer of the local telephone company, you must, if they ask, tell them before connecting your telephone to the telephone company lines. The telephone company may need the FCC registration number and the ringer equivalence of the telephone. This information is printed on a label on the bottom of your telephone.

**RINGER EQUIVALENCE** The ringer equivalence indicates the amount of power that your telephone draws from the telephone company line during ringing. The number is printed on the label on the bottom of your telephone.

If you have more than one telephone (or other terminal device) connected to the telephone company line, you should total the ringer equivalence numbers (REN's), and be sure that the total is not more than five. Your telephones may not ring if the total is more than five. Also, in some rural locations, your telephone may not ring if the REN total is more than three.

**RESTRICTIONS** You must not connect your telephone to coin-operated lines or party lines.

**INTERFERENCE POTENTIAL** Your telephone has a pushbutton dial that generates radio frequency energy. If not properly used, it may interfere with radio and television reception. If the telephone does cause interference with reception, move the radio or television to another electrical circuit or another location. If necessary, you may need to seek advice from an experienced technician.

**INSTALLATION** This model telephone must be connected to the telephone company lines through a modular jack. The required USOC for the modular jack is RJ11C for desk mounting and RJ11W for wall mounting. The USOC number is printed on the label on the bottom of your telephone.

**TYPE OF DIALING** Your telephone has a TONE/PULSE switch that allows Tone or Pulse dialing. To use TONE dialing, you must have TONE service from your telephone company to use your telephone for dialing. Note that you will usually be charged extra for TONE service.

**HEARING-AID COMPATIBILITY** The handset on your telephone will work with magnetically-coupled hearing aids. You can use a hearing aid equipped with a T (Telephone) switch.

**IN CASE OF TROUBLE** If your telephone should cause problems on the telephone line, the telephone company can temporarily disconnect your service. The telephone company must then notify and allow you to correct the problem.

The telephone company may from time to time change its lines or equipment. They must notify you if planned changes will affect your telephone service, to allow you to take steps to prevent interruptions.

This device complies with Part 15 of the FCC Rules. Operation is subject to the following two conditions: (1) this device may not cause harmful interference, and (2) this device must accept any interference received, including interference that may cause undesired operation.

*Warning: Changes or modifications to this unit not expressly approved by the party responsible for compliance could void the user's authority to operate the equipment.*

**NOTE:** This equipment has been tested and found to comply with the limits for a CLASS B digital device, pursuant to Part 15 of the FCC Rules. These limits are designed to provide reasonable protection against harmful interference in a residential installation. This equipment generates, uses, and can radiate radio frequency energy and, if not installed and used in accordance with the instructions, may cause harmful interference to radio communications. However, there is no guarantee that interference will not occur in a particular installation. If this equipment does cause harmful interference to radio or television reception, which can be determined by turning the equipment off and on, the user is encouraged to try to correct the interference by one or more of the following measures:

- Reorient or relocate the receiving antenna.
- Increase the separation between the equipment and receiver.
- Connect the equipment into an outlet on a circuit different from that to which the receiver is connected.
- Consult the dealer or an experienced radio TV technician for help.

# LIMITED WARRANTY

If this telephone was purchased by you new in the U.S. or Puerto Rico, **Cortelco** warrants the telephone against defects in material and workmanship for a period of two (2) years from the date of original purchase. This warranty is in lieu of all other express warranties. During the warranty period, **Cortelco** agrees to repair or, at its option, replace the defective telephone, or any part of it, without charge for parts or labor. This is your exclusive remedy. This warranty does not cover damage resulting from accident, misuse, abuse, improper installation or operation, lack of reasonable care, the affixing of any attachment not provided by **Cortelco** with the telephone and loss of parts. The warranty is voided in the event any unauthorized person alters or repairs the telephone.

Telephone companies use different types of equipment and offer various types of services to customers. **Cortelco does not warrant that this telephone is compatible with the type of equipment of any particular phone company or the services provided by it.**

**Cortelco** DISCLAIMS ANY IMPLIED WARRANTY, INCLUDING THE WARRANTY OF MERCHANTABILITY AND THE WARRANTY OF FITNESS FOR A PARTICULAR PURPOSE, AS OF THE DATE ONE YEAR FROM THE ORIGINAL PURCHASE OF THE TELEPHONE. **Cortelco** ASSUMES NO RESPONSIBILITY FOR ANY SPECIAL, INCIDENTAL OR CONSEQUENTIAL DAMAGES.

THIS WARRANTY GIVES YOU SPECIFIC LEGAL RIGHTS, AND YOU MAY HAVE OTHER RIGHTS WHICH VARY FROM STATE TO STATE. SOME STATES DO NOT ALLOW THE EXCLUSION OR LIMITATION OF SPECIAL, INCIDENTAL OR CONSEQUENTIAL DAMAGES OR LIMITATIONS ON HOW LONG AN IMPLIED WARRANTY LASTS, SO THE ABOVE EXCLUSION AND LIMITATION MAY NOT APPLY TO YOU.

If failure occurs and your telephone is in warranty, service shall be provided by returning the telephone to **Cortelco - Repair Center, 1703 Sawyer Road, Corinth, Mississippi 38834, shipping prepaid.** The telephone will be repaired or replaced if examination by us determines the telephone to be defective. Telephones received damaged as a result of shipping will require you to file a claim with the carrier.