

## EASYPACK

### **E** Armarios 19" para el soporte mural de instalaciones de redes, telecomunicaciones y equipos electrónicos.

Diseñado según normas IEC 60 297-2, DIN 41494 partes 1 y 7, ANSI / EIA-310-D y UNE 20 539-2.

- Premontado en Flat-Pack. Montaje de estructura sin herramientas.
- 2 perfiles 19" de acero, espesor 1.5 mm, desplazables en profundidad.
- Fijación rápida con dos tornillos de 1/4 de vuelta.
- Puerta frontal de vidrio de seguridad, espesor 4 mm, con marco en perfil de aluminio. Sentido de apertura alternable en montaje y cierre por llave.
- Sin puerta posterior, excepto 18U en versión al suelo: en acero 1 mm, sentido apertura alternable en montaje, con cierre por llave.
- Laterales con tapas desmontables (excepto SOHO), con cierres rápidos de 1/4 de vuelta.
- Tapas sup./inf. con premecanizados para fijación de unidad de ventilación de 1 o 2 ventiladores. Incluye tapetas de plástico (sup./inf.) mecanizables para paso de cables.
- Plantilla de montaje a pared incluida (no incluye tornillos de montaje a pared).
- Pies de nivelación en 18U versión a suelo.
- Capacidad de carga recomendada: 40 Kg.

**Acabados:** Pintado epoxy gris grafito texturizado, cantoneras similar a RAL 5007.

**Entrega:** Premontado (Flat-pack) en caja de cartón con asa de plástico (excepto versiones SOHO y FRAME).

### **EN** 19" wall mounted cabinets. For cabling, telecommunications, IT and industrial installations.

Designed in accordance with IEC60 297-2, DIN 41944 part 1 and 7, ANSI/EIA-310 and UNE 20 539-2.

- Delivered flat packed for ease of access to all installations. Also reduces associated logistic costs and offers greater protection during transit.
  - Fast and efficient assembly without tools.
  - 2x 19" mounting profiles. Variable depth, in 20mm increments. Numbered "U's" optional.
  - Fast fixings 1/4 turn locks.
  - New front door with aluminium frame. Tempered, smoked safety glass.
  - No rear panel or door. 18U self-standing version includes rear door with key lock as standard.
  - Easily removable side panels with 2x 1/4 turn locks. Except SOHO version.
  - Newly designed top and base panels, with ventilated areas for installation of the new modular fan trays.
  - New cable entry options for the top panels. With plastic blanking covers or optional brush strip fittings.
  - Template for wall mounting, included.
  - Levelling feet included with the 18U self-standing version.
  - Distributed recommended load capacity: 40 Kg
- Finishes:** Graphite Grey epoxy paint and standard blue corners pieces similar to RAL 5007
- Delivery:** Flat packed with carrying handle. (Except SOHO and FRAME versions).

### **F** Coffrets muraux 19", pour installations de câblage, Télécommunications, IT et installations industrielles. Conception selon les normes IEC 60 297-2, DIN 41944 part. 1 & 7, ANSI/EIA-310 et UNE 20 359-2.

- Livraison en emballage "Flat-pack" pour un accès facilité quelque soit le lieu de l'installation, réduisant de même les besoins et les coûts logistiques, tout en assurant également une meilleure protection lors du transport.
  - Assemblage rapide et efficient sans outillage.
  - 2x Profilés intérieurs 19". Profondeur variable par pas de 20 mm. Numérotation des "U" en option. Fixation rapide par boulons 1/4 de tour.
  - Nouvelle porte avec cadre d'aluminium et verre de sécurité trempé et fumé.
  - Pas de panneau postérieur ou de porte. Seule la version 18U de sol en produit standard inclut une porte postérieure avec serrure.
  - Latéraux facilement démontables par 2 boulons 1/4 de tour, à l'exception de la version SOHO.
  - Nouveaux design de panneaux de toit avec zones d'aération prêtes pour le montage des nouvelles unités de ventilation modulaire.
  - Nouvelles sorties de câblage en toit et base pour l'installation de panneaux passe-câbles à balai ou bien de panneaux pleins mécanisables.
  - Plan fourni pour le montage mural. Pies de nivellement inclus dans la version 18U de sol. Capacité de charge distribuée recommandée: 40 Kg.
- Finitions:** peinture époxy gris graphite, couvercles de cornières standard en bleu similaire à RAL 5007.
- Emballage:** en "Flat pack". Avec poignée de transport (excepté FRAME).



EASYPACK



EASYPACK 18U STAND



EASYPACK SOHO



EASYPACK FRAME



## EASYPACK

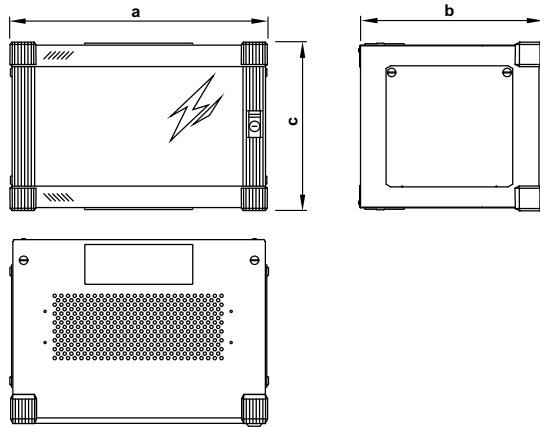

Code	19"	U/HE	a	b	c	Puerta frontal Front door Porte frontale	Puerta posterior Rear door Porte arrière
32250406	*	6	580	421	384	*	
32250409	*	9	580	421	517	*	
32250606	*	6	580	621	384	*	
32250609	*	9	580	621	517	*	
32250512	*	12	580	521	651	*	
32250612	*	12	580	621	651	*	
32250515	*	15	580	521	784	*	
32250615	*	15	580	621	784	*	
32250618	*	18	580	621	917	*	
32252618	*	18	580	621	917	*	*

## EASYPACK SOHO

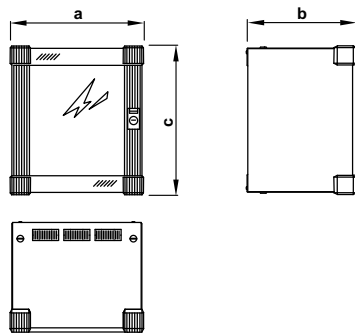

Code	19"	U/HE	a	b	c	Puerta frontal Front door Porte frontale	Puerta posterior Rear door Porte arrière
32251307		7	385	315	428	*	

## EASYPACK FRAME

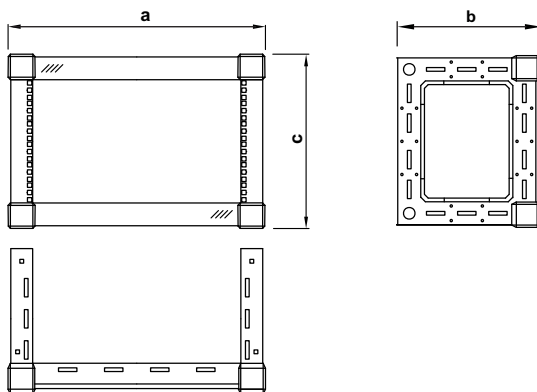

Code	19"	U/HE	a	b	c	Puerta frontal Front door Porte frontale	Puerta posterior Rear door Porte arrière
32250106	*	6	559	316	378		



Embalaje Flat-pack en toda la gama.  
Flat-pack for all the ranges  
Livraison en Flat-pack pour toute la gamme.



**EASYRACK**  
6, 9, 12, 15, 18U

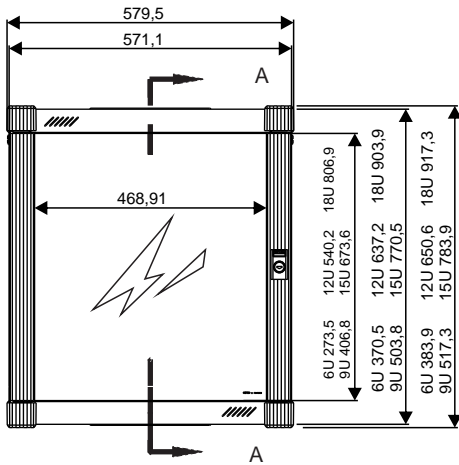
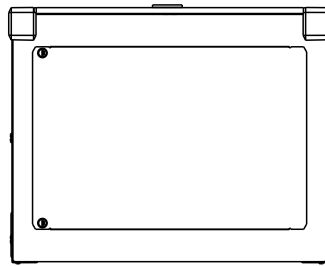
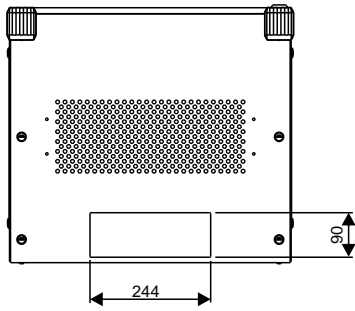

SIN PUERTA / WITHOUT DOOR / SANS PORTE

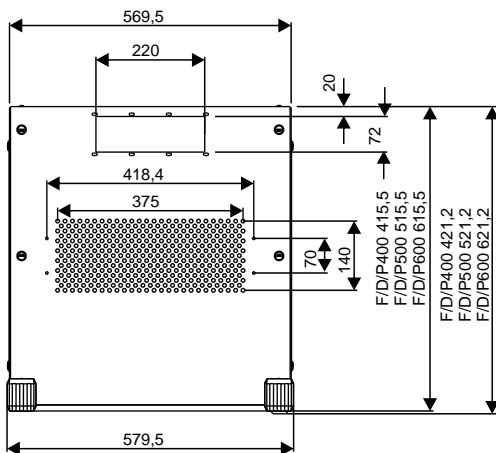
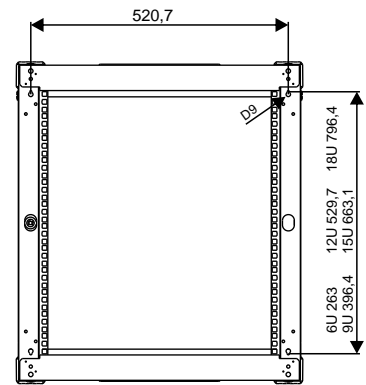
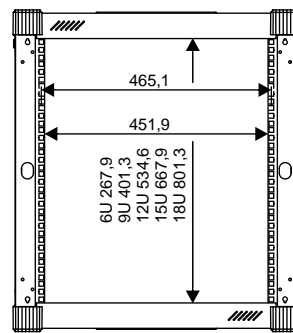

A-A

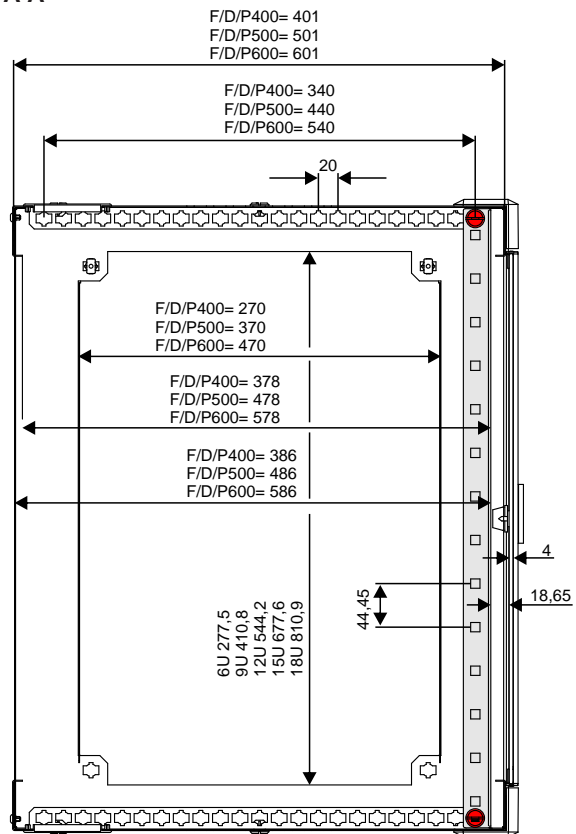

**EASYPACK 18U STAND**  
**( CODE 32252618 )**

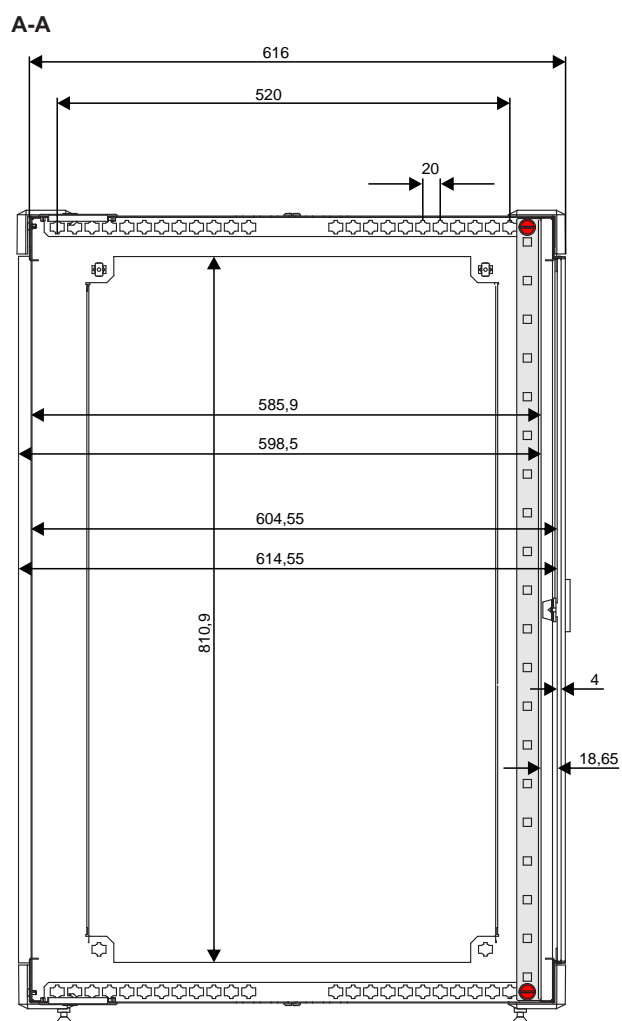
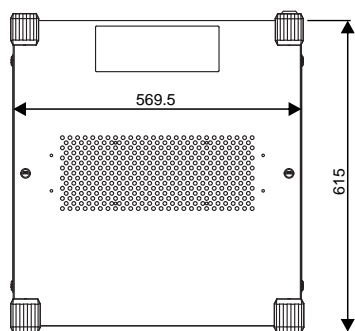
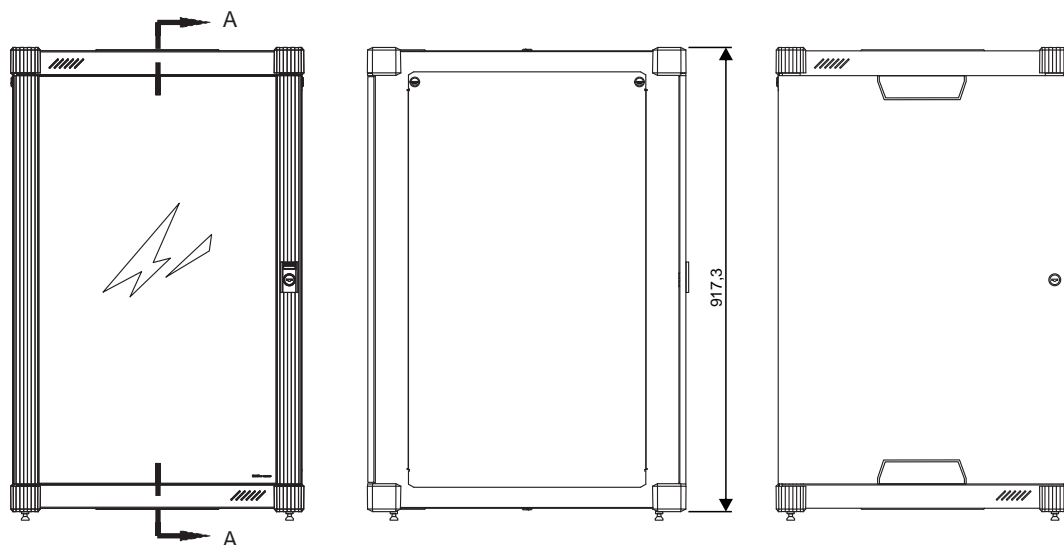

## EASYPACK SOHO

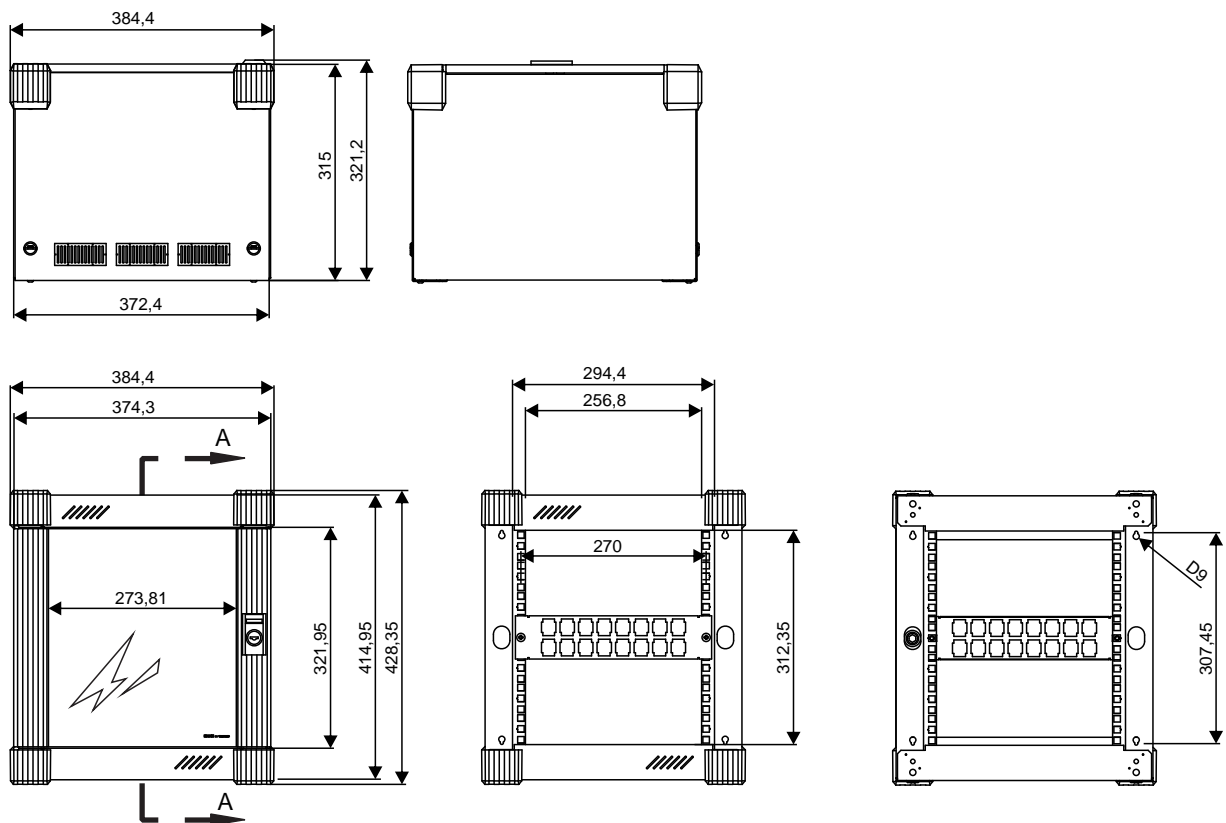

## EASYPACK FRAME

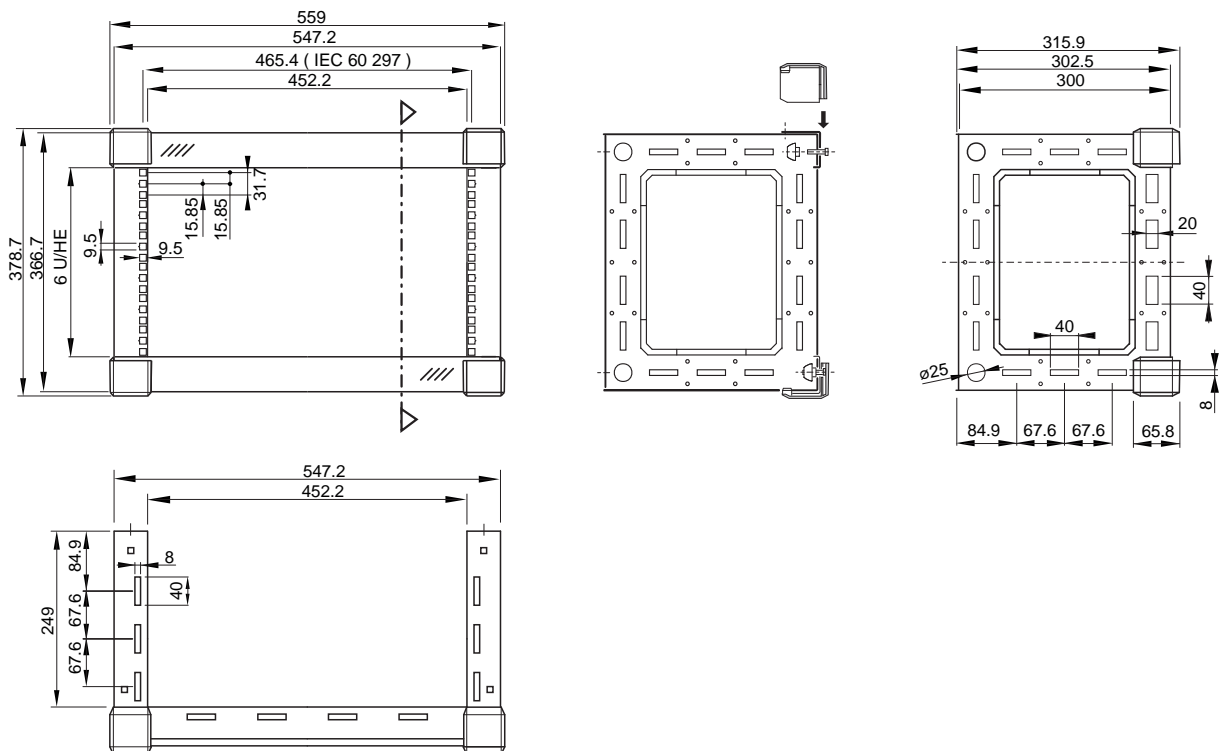

ARGENTINA - AUSTRALIA - BELARUS - BELGIUM - BRAZIL - BULGARIA - CHILE - COLOMBIA - DENMARK - DOMINICAN REPUBLIC - FINLAND - FRANCE - GERMANY - GREECE - HONG KONG - INDIA - ISRAEL - ITALY - JAPAN - LEBANON - MACAO - MALTA - MAURITIUS - MEXICO - MOROCCO - NORWAY - PARAGUAY - PORTUGAL - REUNION - ROMANIA - RUSSIA - SPAIN - SWEDEN - SWITZERLAND - SYRIA - THE NETHERLANDS - TUNISIA - UNITED KINGDOM - UNITED STATES - URUGUAY



#### RETEX

RETEX, S.A.  
Avda. Tecnología, 35  
08840 VILADECANS (Barcelona)  
España  
[www.retex.es](http://www.retex.es)  
email: [retex@retex.es](mailto:retex@retex.es)  
Tel +34 93 264 98 50  
Fax +34 93 659 23 68

#### RETEX Latinoamérica Uruguay

RETEX TELECOMUNICACIONES, S.A.  
Pereira de la Luz, 1080  
11300 MONTEVIDEO  
Uruguay  
[www.retextelecom.com](http://www.retextelecom.com)  
email: [retex@retextelecom.com](mailto:retex@retextelecom.com)  
Tel. +5982 6223408  
Fax +5982 2045797

#### RETEX Asia India

RETEX RACKS & ENCLOSURES PVT LTD.  
D-220 Ansa Industrial Estate Road  
Saki-Vihar Road, Andheri East  
MUMBAI 400072  
India  
[www.retex.co.in](http://www.retex.co.in)  
email: [retex@retex.co.in](mailto:retex@retex.co.in)  
Phone: +9122 28575934



RETEX colabora con la ONG [www.figueralia.org](http://www.figueralia.org)  
RETEX collaborates with the NGO [www.figueralia.org](http://www.figueralia.org)  
RETEX collabore avec la ONG [www.figueralia.org](http://www.figueralia.org)

01/2011. Code 77200050.  
RETEX, S.A. se reserva el derecho a introducir modificaciones en la información de este catálogo sin previo aviso. RETEX, S.A. reserves the right to change the information included in this catalogue without prior notice. RETEX, S.A. se réserve le droit de procéder a des modifications des informations du présent catalogue sans préavis.