



Quam

WS20X12 Wall Mount Equipment Shelf, Black

WS20X12/W Wall Mount Equipment Shelf, White

0701 - WALL MOUNT EQUIPMENT SHELVES

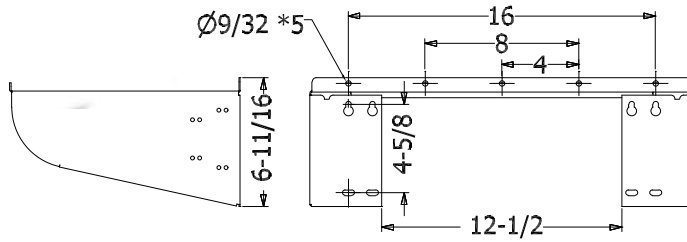
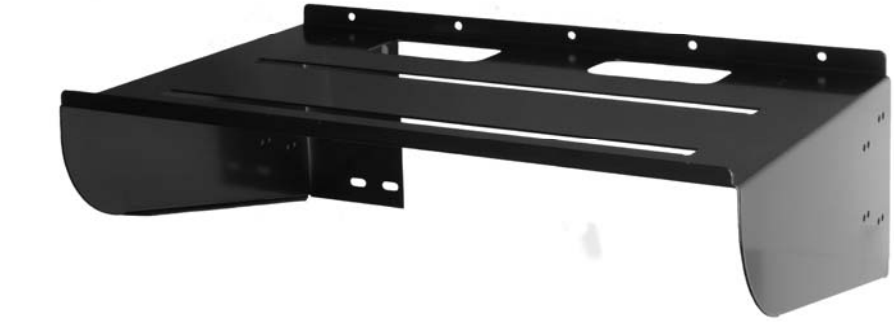
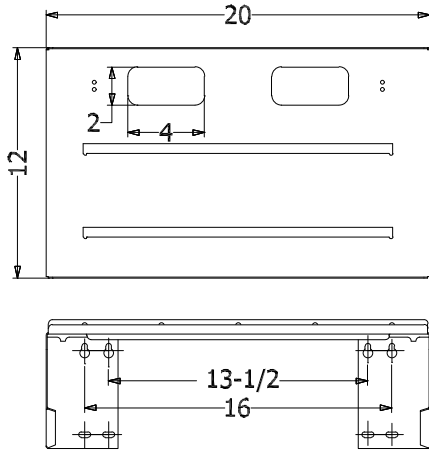

GENERAL DESCRIPTION

The Quam WS20X12 is a steel, wall mounted equipment shelf consisting of a horizontal perforated platform with two reinforcement ribs, 1/2" raised front lip, two support arms; no assembly is required.
Finish: Baked epoxy hybrid.

FINISH OPTIONS

Black	Order as: WS20X12
White	Order as: WS20X12/W

INTENDED USE

Indoor, mounted perpendicular to wall surface and parallel to floor. Static load as noted in specifications.

OPTIONAL QUAM ACCESSORY

Kit#113- Set of brackets permit mounting of one QUAM 2RU attenuator rack panel between support arms and below the shelf surface.
Fits either QC20 or QC101M rack panels in 1,2,3,4,5 or 6 unit configurations.

SPECIFICATIONS

Static Load Capacity	WS20X12 - 100 pounds*
----------------------	-----------------------

*SAFETY WARNING! It is the responsibility of the Contractor and the AHJ to determine fastener type and method based on static load, mounting structure and local building codes.

Recommended construction sequences, installation instructions and A&E Specifications are available in various formats on the Quam Architects' and Engineers' Resources CD or on the web at: www.quamspeakers.com

Quam-Nichols Company

234 East Marquette Road, Chicago, IL 60637
 Phone: (800) NEED NOW Fax: (888) NEED NOW
 (800) 633 - 3669 (888) 633 - 3669
 E-Mail: neednow@qnc.com www.quamspeakers.com



07 SHELVES