

1", 2", 3", AND 4"
REAR SECTION NOMINAL
CONCENTRIC CONDUIT
KNOCKOUT

FAN KNOCKOUTS FOR
7217WS ASSEMBLY LOCATED
ON TOP AND BOTTOM

DIA. 1/2" - 13 THREADS
TOP AND BOTTOM
5 PLACES

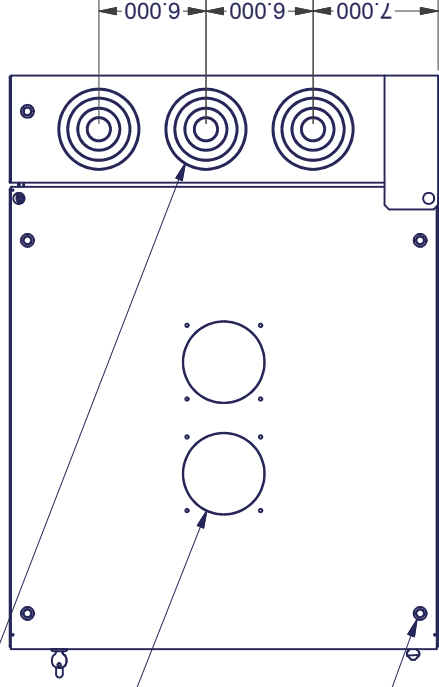

TOP VIEW

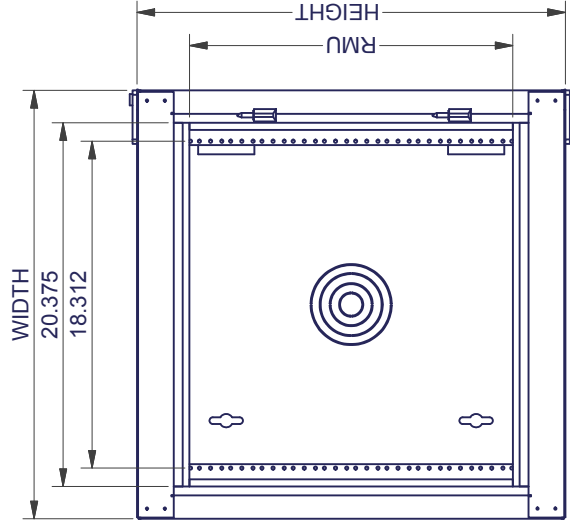

FRONT VIEW
(without Door)

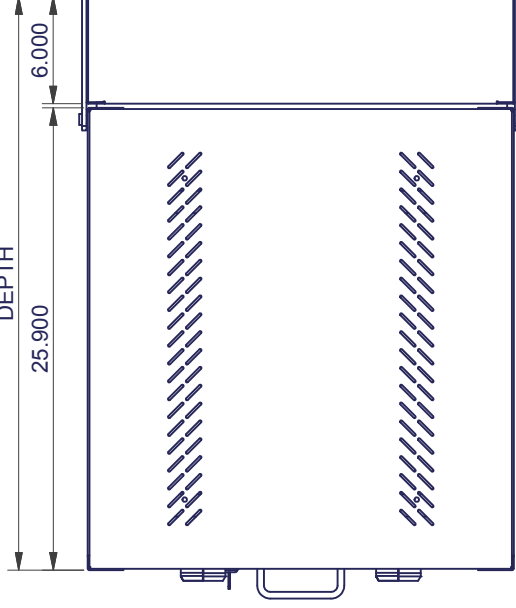

RIGHT SIDE VIEW

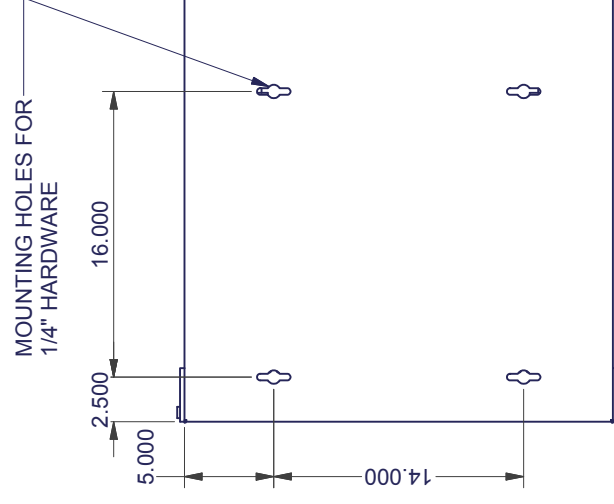

BACK VIEW

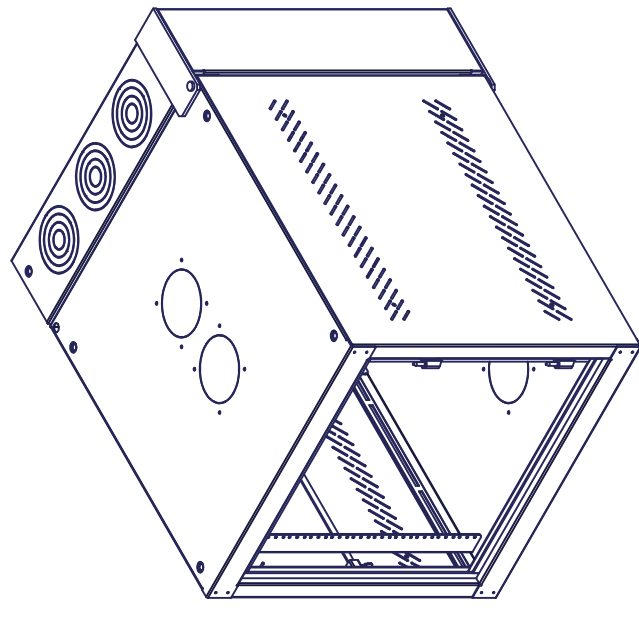

ISO COLLAPSED
(without Door)

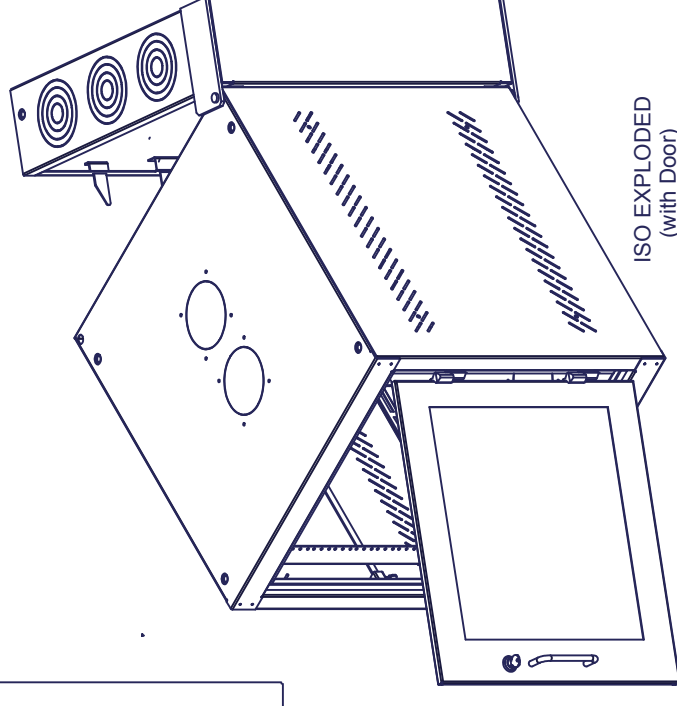

ISO EXPLODED
(with Door)

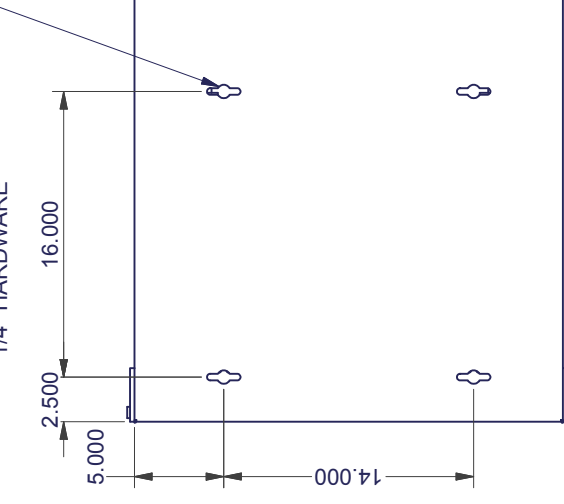

FRONT VIEW
(with Door)

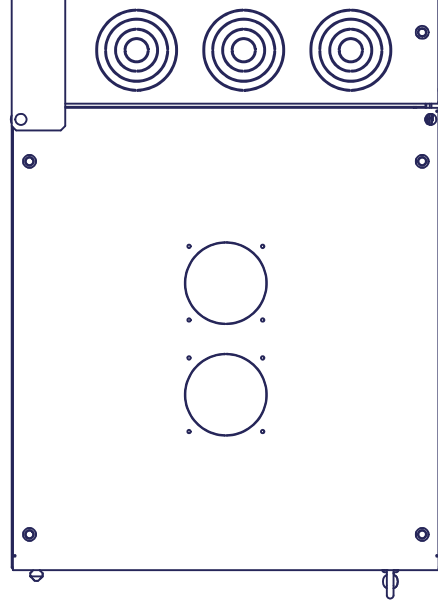

BOTTOM VIEW

| Part No. | H | W | D | RMU |
|----------|--------|--------|--------|-----|
| GL24WD | 24.00" | 24.00" | 32.13" | 11 |
| GL36WD | 36.00" | 24.00" | 32.13" | 18 |
| GL48WD | 48.00" | 24.00" | 32.13" | 25 |

INTERPRET DRAWING PER ASME Y14.5M-1994

DIMENSIONAL LIMITS APPLY
AFTER APPLICATION OF FINISH
DRAWING NOT TO SCALE
TOLERANCE UNLESS OTHERWISE NOTED:
ANGULAR +/- 1
.XXX +/- .010
.XX +/- .015
.X FOR REF ONLY

UNLESS OTHERWISE SPECIFIED
ALL DIMENSIONS ARE IN INCHES



NOTICE:

Use of this document is subject to a confidentiality and nondisclosure agreement with Great Lakes Case & Cabinet Co., Inc. (GLCC) and may not be reproduced, disclosed or utilized in whole or in part without prior written authorization from GLCC.

PART NUMBER: _____

QTY PER UNIT: 1

MATERIAL TYPE: _____

MATERIAL GAUGE: _____

FINISH: SEE NOTES

DRAWN: _____ DATE: 1/11/2011

CHECKED & APP. DATE: 1/11/2011

WSS

TITLE: _____

GREAT LAKES CASE & CABINET CO., INC.

P.O. BOX 551 EDINBORO, PA 16412

PHONE (814) 734-7303 FAX (814) 734-3907

E-MAIL glcc@greatlakes.com

DWG NO: 1013250

REV: 0

SHEET: 1 OF 1