



## INSTALLATION AND OPERATION MANUAL

# FDX60(M)(S)(-M)

## SINGLE OR DUAL RS232/RS422/RS485(2/4W) DATA TRANSCEIVER

The ComNet™ FDX60(M)(S)(-M) data transceivers provide point-to-point transmission of simplex or duplex EIA RS232/RS422/RS485 (2W/4W) data signals over one or two optical fibers. The transceivers are transparent to data encoding allowing for broad-range compatibility. Models within this series are available for use with multimode or single mode optical fiber.

Each transceiver incorporates a bi-color (Red/Green) indicating LED for monitoring proper system operation. See **Figure 8** on **Page 6** for LED Indicator explanations.

The FDX60(M)(S)(-M) has a built-in fiber link test feature that allows for the testing of the fiber. See **Figure 13** on **Page 8** for an explanation of the Loop Back Test Mode.

The FDX60(M)(S) may be directly plugged into the ComNet Rack (Part C1) or they can operate as standalone modules. The FDX60(M)(S)-M has a small footprint and is designed for surface mounting. See **Figures A** and **B** on **Page 9** for mounting instructions.

See **Figures 1 – 13** for complete installation details.

FIGURE 1 – FDX60 1 FIBER TRANSCEIVER

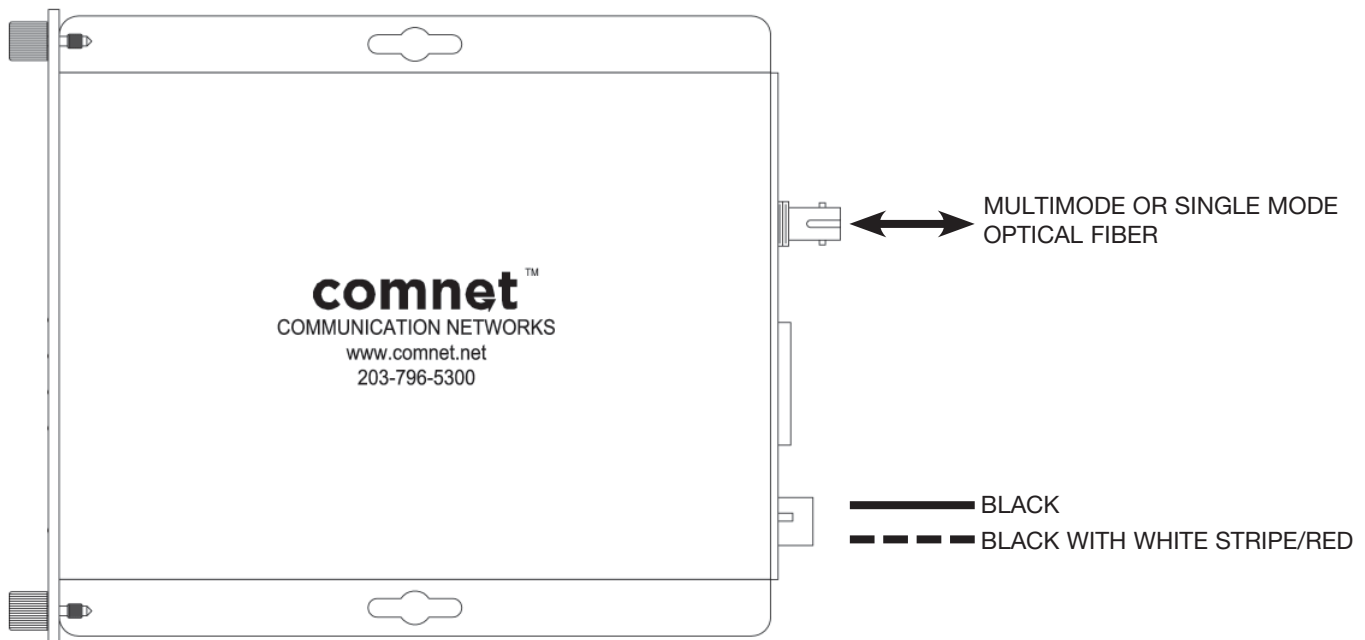

FIGURE 2 – FDX60 1 FIBER TRANSCEIVER

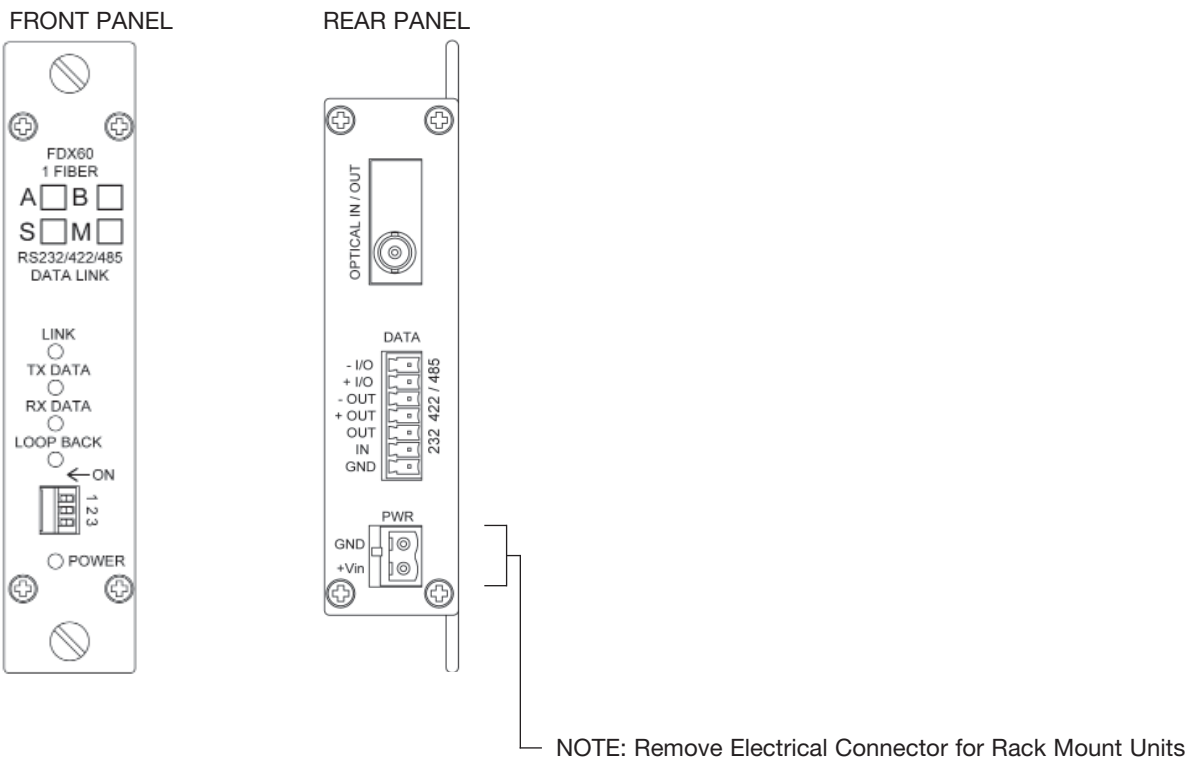

FIGURE 3 – FDX60 2 FIBER TRANSCEIVER

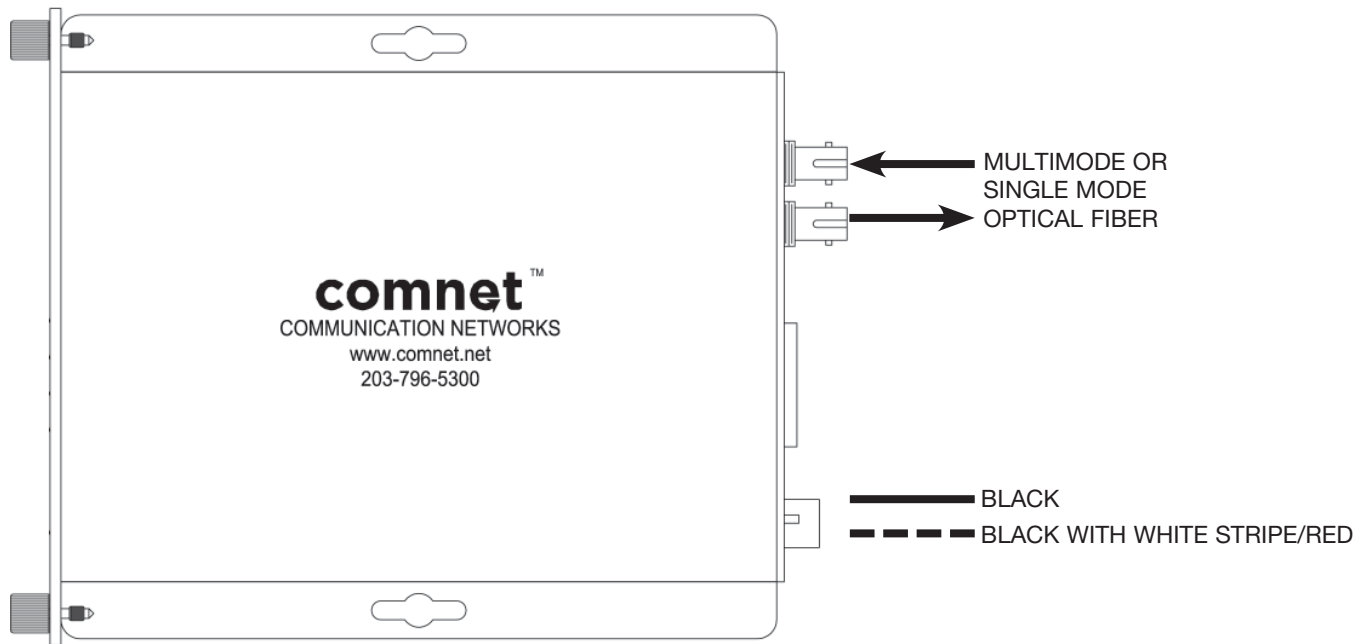

FIGURE 4 – FDX60 2 FIBER TRANSCEIVER

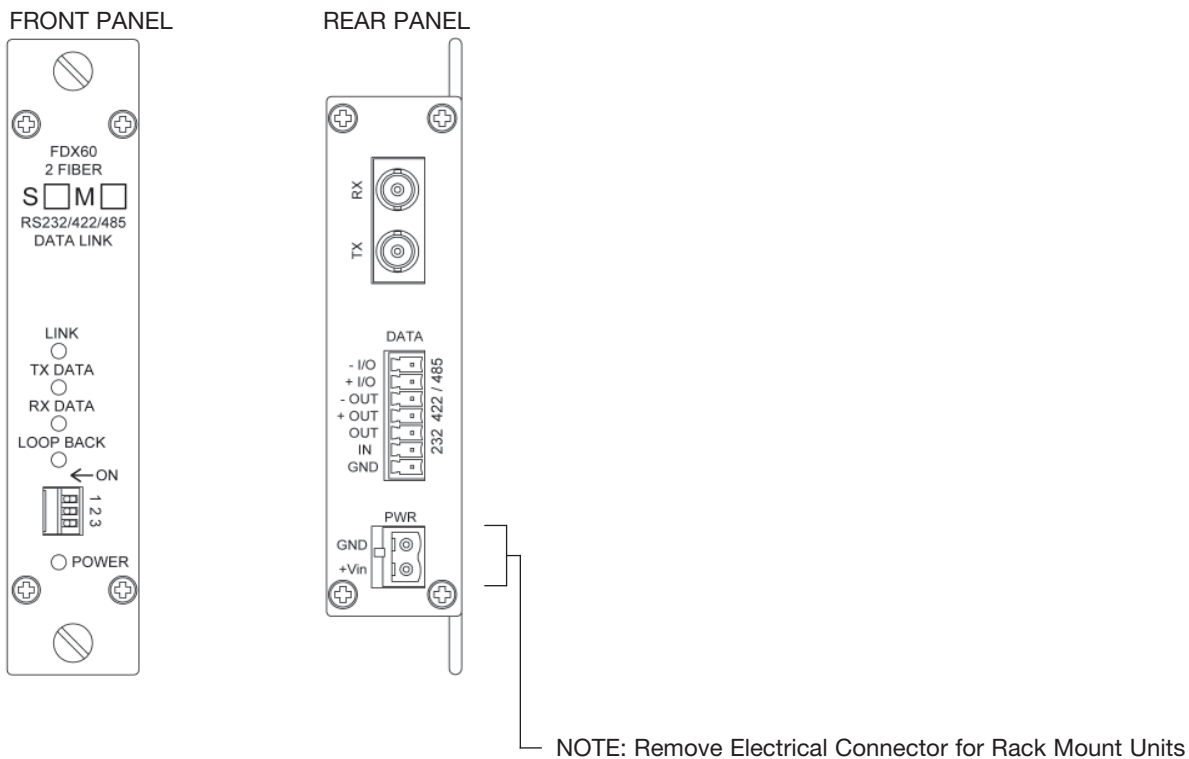

FIGURE 5 – FDX60-M 1 FIBER TRANSCEIVER

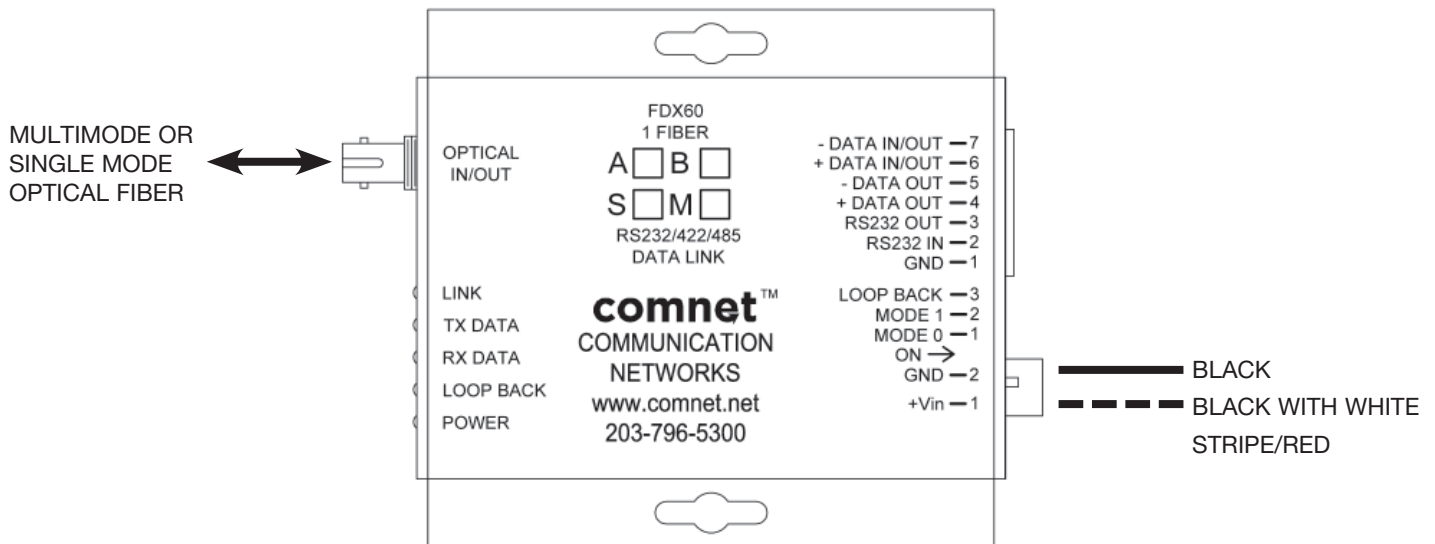

FIGURE 6 – FDX60-M 1 FIBER TRANSCEIVER

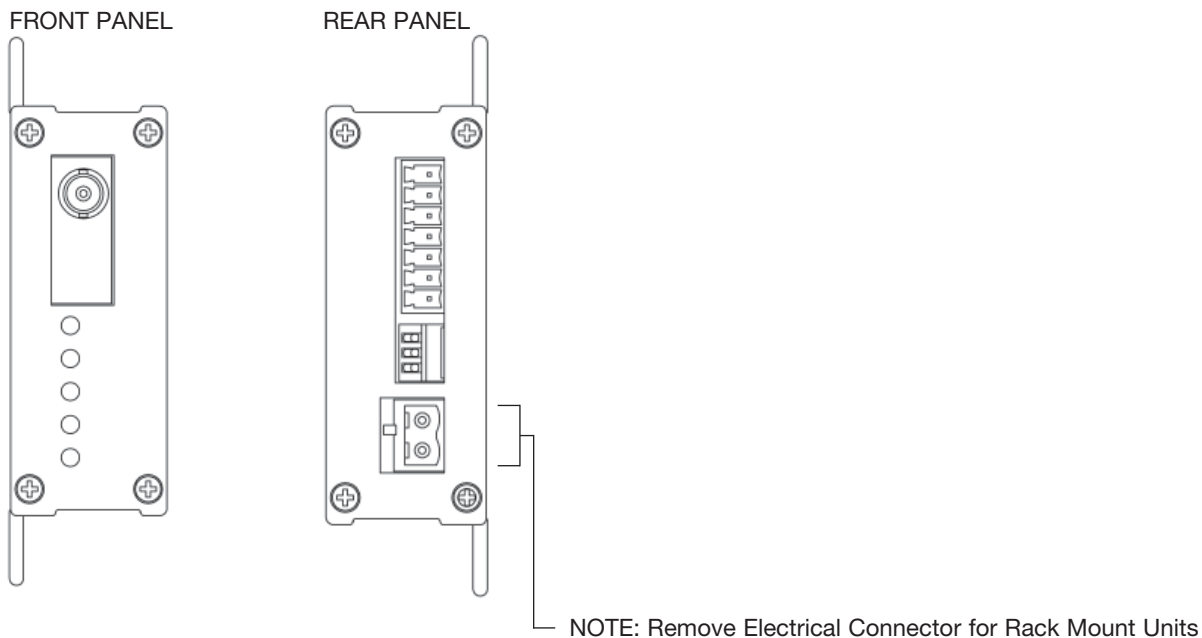

FIGURE 7 – FDX60-M 2 FIBER TRANSCEIVER

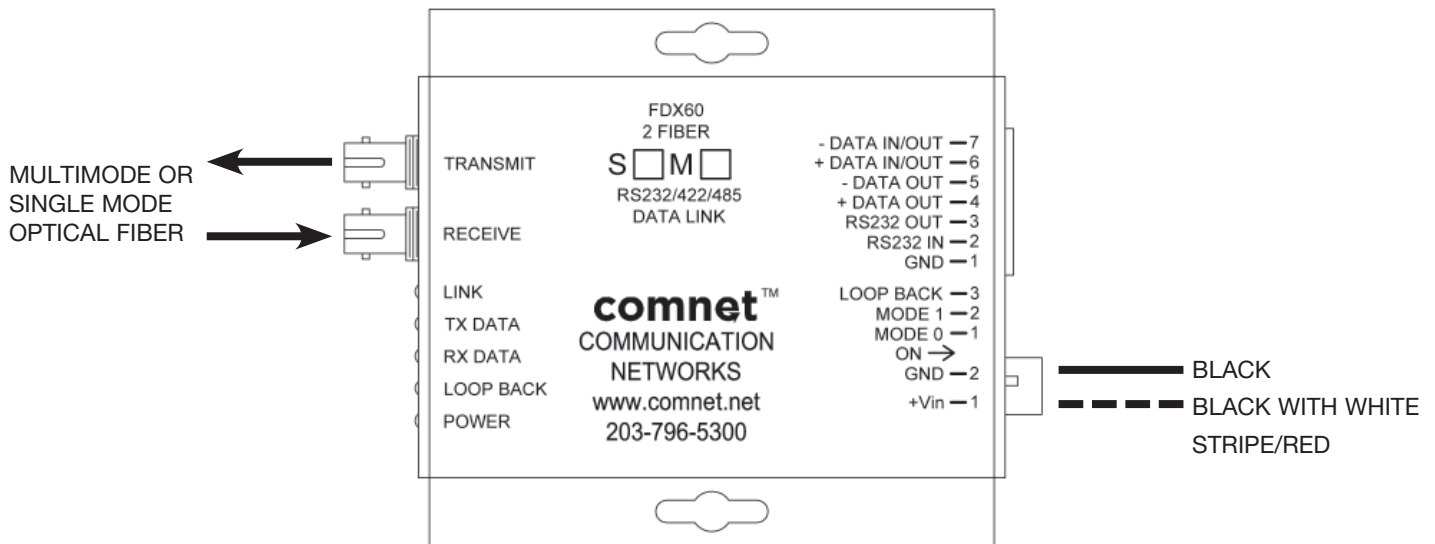
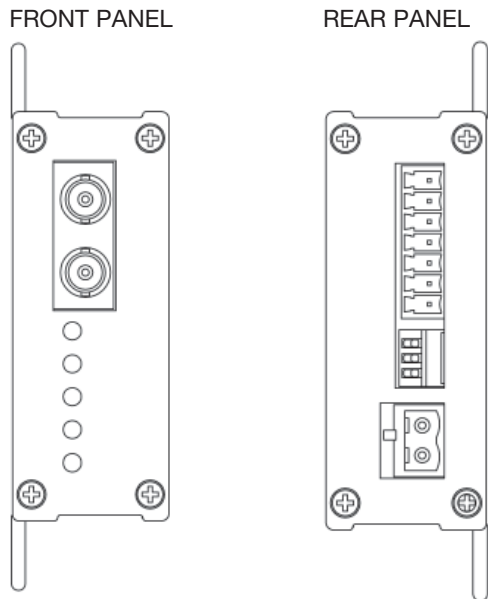

FIGURE 8 – FDX60-M 2 FIBER TRANSCEIVER



NOTE: Remove Electrical Connector for Rack Mount Units

FIGURE 9 – LED INDICATORS

|       | LINK             | DATA (TX/RX) | LOOP BACK (Test Mode)                                     | POWER             |
|-------|------------------|--------------|---|-------------------|
| GREEN | Unit In Sync     | Activity     | Fiber Link Connections are Correct                        | Unit Powered Up   |
| RED   | Unit Not In Sync | No Activity  | Fiber Link Issue Exists (Head End)                        | –                 |
| OFF   | No Optical Link  | –            | Fiber Link Issue Exists (Far End);<br>OR Test Mode is Off | Unit Powered Down |

FIGURE 10 – SWITCH POSITIONS



**Switch**

Located on front panel in full size modules and on back on small size modules.

The first two switches set the data type, the third toggles Loop Back Test Mode.

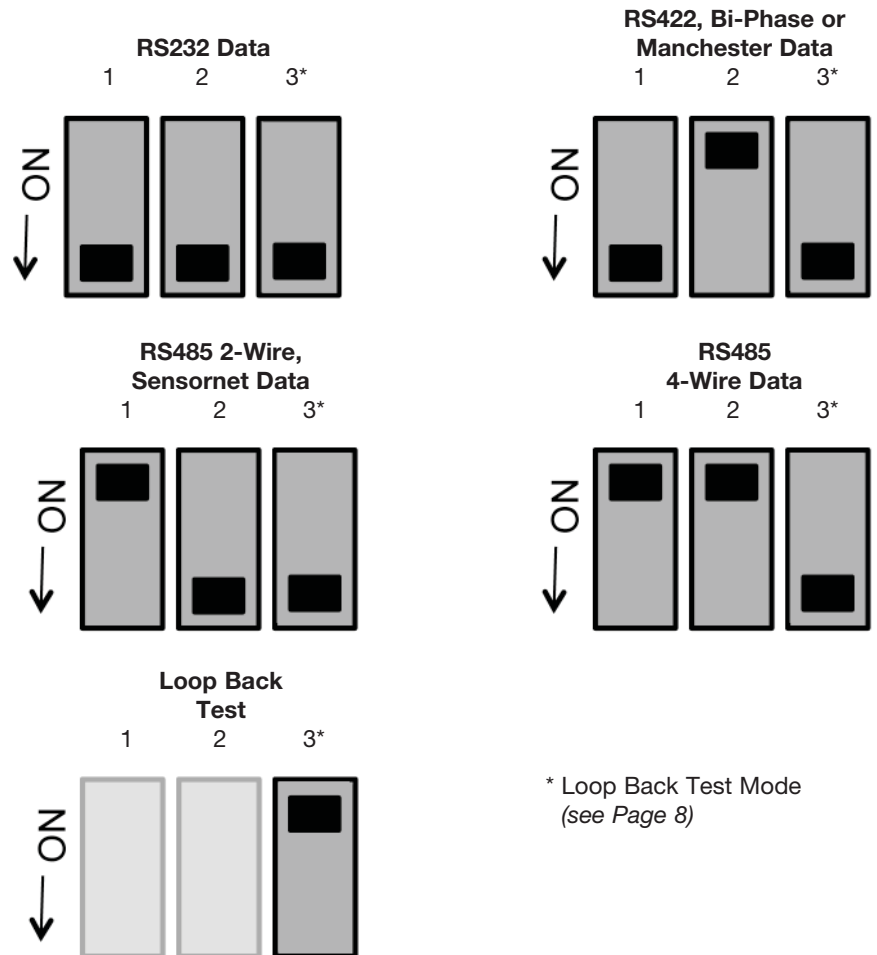

\* Loop Back Test Mode  
(see Page 8)

FIGURE 11 – DATA CONNECTIONS

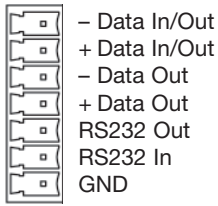
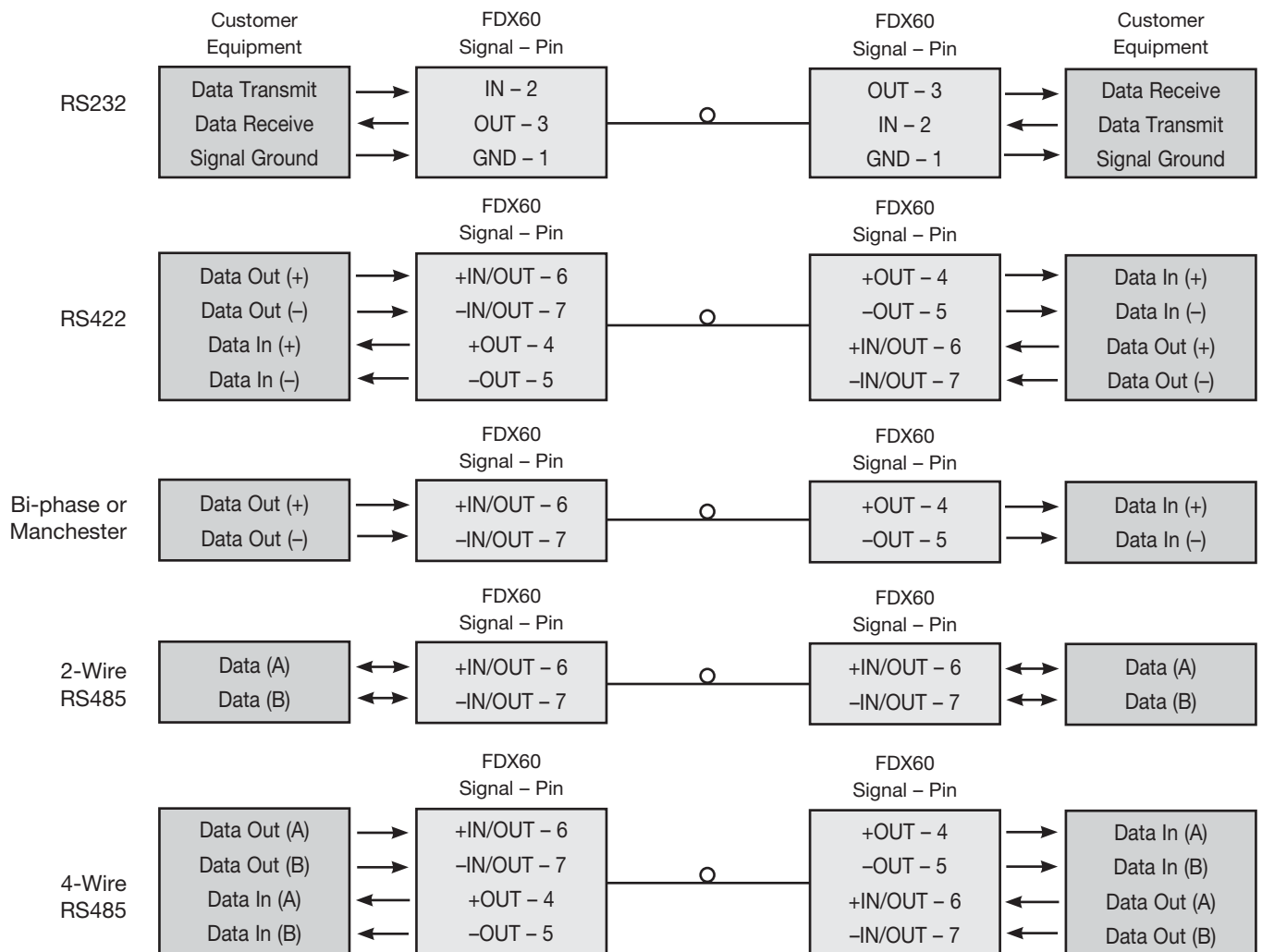
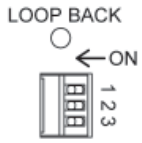

FIGURE 12 – DATA SETTINGS



**FIGURE 13 – LOOP BACK TEST MODE**



1. On one end (Head End), put unit into Loop Back Mode by setting Switch 3 to “OFF.” Switch 1 and 2 can be in any position. Data will not pass during Loop Back Test, LEDs may flash if data is sent during Loop Back Test.
2. If the Far End unit is powered on and the fiber link connections are correct, the Far End unit Loop Back LED will light GREEN.
3. If the Head End unit has Switch 3 in the “ON” position, and if there is a fiber link issue, then the Far End unit Loop Back LED will remain OFF. This is an error condition.
4. If the Far End unit Loop Back LED is GREEN and the fiber link and optical connections back to the Head End unit are correct, then the Head End unit Loop Back LED will light GREEN.
5. If there is a fiber link issue from the Far End back to the Head End, or the Far End unit is not working, the Head End unit Loop Back LED will light RED when the Loop Back switch is set to OFF. This is an error condition.
6. When not in Loop Back Test Mode the Loop Back LED on both ends will be OFF.



# MECHANICAL INSTALLATION INSTRUCTIONS

## INSTALLATION CONSIDERATIONS

This fiber-optic link is supplied as a Standalone/Rack module. Units should be installed in dry locations protected from extremes of temperature and humidity.

### C1-US, C1-EU, C1-AU OR C1-CH CARD CAGE RACKS

**CAUTION:** Although the units are hot-swappable and may be installed without turning power off to the rack, ComNet recommends that the power supply be turned off and that the rack power supply is disconnected from any power source. **Note:** Remove electrical connector before installing in card cage rack.

1. Make sure that the card is oriented right side up, and slide it into the card guides in the rack until the edge connector at the back of the card seats in the corresponding slot in the rack's connector panel. Seating may require thumb pressure on the top and bottom of the card's front panel.

**CAUTION:** Take care not to press on any of the LEDs.

2. Tighten the two thumb screws on the card until the front panel of the card is seated against the front of the rack.

**WARNING:** Unit is to be used with a Listed Class 2 or LPS power supply rated 9-12 VDC @ 1A.

### IMPORTANT SAFEGUARDS:

**A) Elevated Operating Ambient** - If installed in a closed or multi-unit rack assembly, the operating ambient temperature of the rack environment may be greater than room ambient. Therefore, consideration should be given to installing the equipment in an environment compatible with the maximum ambient temperature (T<sub>ma</sub>) specified by the manufacturer.

**B) Reduced Air Flow** - Installation of the equipment in a rack should be such that the amount of air flow required for safe operation of the equipment is not compromised.



3 CORPORATE DRIVE | DANBURY, CT 06810 | USA  
 T: 203.796.5300 | F: 203.796.5303 | TECH SUPPORT: 1.888.678.9427 | INFO@COMNET.NET  
 8 TURNBERRY PARK ROAD | GILDERSOME | MORLEY | LEEDS, UK LS27 7LE  
 T: +44 (0)113 307 6400 | F: +44 (0)113 253 7462 | INFO-EUROPE@COMNET.NET

**FIGURE A**

Dimensions are for a standard ComNet™ one slot module

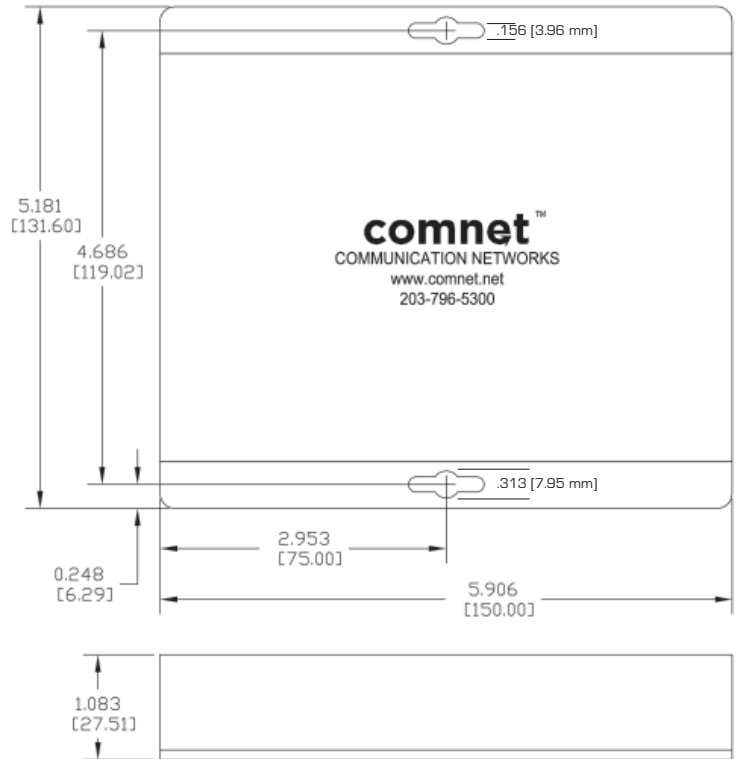

**FIGURE B**

Dimensions are for a small size ComNet™ surface mount module

