

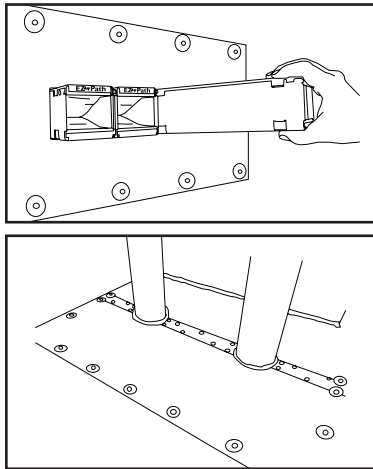

COMPOSITE SHEET

APPLICATIONS

SpecSeal® Composite Sheet is used in conjunction with other STI Firestop Products to seal penetrations through both fire-resistance rated walls and floors for metallic and non-metallic pipes, insulated pipes, cable trays, cables, conduits, or blank openings. SpecSeal® Composite Sheet provides an effective seal against fire, smoke, and combustion byproducts for openings of any shape in common construction assemblies.



PRODUCT DESCRIPTION

SpecSeal® Composite Sheet is a lightweight, rigid fire resistant panel consisting of an intumescent layer bonded to a galvanized steel sheet reinforced with steel wire mesh covered with aluminum foil. SpecSeal® Composite Sheet is designed to seal medium to large size openings with a variety of different penetrants in both fire-resistance rated floors and walls.

When exposed to temperatures in excess of 350°F (177°C), SpecSeal® Composite Sheet expands minimum 15x to form a dense insulative char that minimizes heat transfer.

FEATURES

- **Lightweight** for easy handling and fabrication and less hanging weight on walls
- **Easy to cut** using sheet metal tools
- **Highly intumescent** – expands up to 15X
- **Hole Reduction** - Used in conjunction with other SpecSeal® or EZ-PATH® Products for reducing large openings
- **Versatile performer** for a wide range of complex applications
- **Paintable**

PERFORMANCE

SpecSeal® Composite Sheet is the basis for firestop systems that meet the exacting criteria of ASTM E 814 (ANSI/UL 1479). UL Systems have been tested for all common forms of construction and many common penetrating items with ratings up to 2 hours.

	<p>FILL, VOID OR CAVITY MATERIALS CLASSIFIED BY UNDERWRITERS LABORATORIES INC. ® FOR USE IN THROUGH-PENETRATION FIRESTOP SYSTEMS. SEE UL FIRE RESISTANCE DIRECTORY. CLASSIFIED FILL, VOID, OR CAVITY MATERIALS FOR USE IN THROUGH-PENETRATION FIRESTOP SYSTEMS. SEE UL DIRECTORY OF PRODUCTS CERTIFIED FOR CANADA AND UL FIRE RESISTANCE DIRECTORY.</p>	
--	--	--

SPECIFICATIONS

The composite sheet shall be lightweight panel comprised of an intumescent layer bonded to a galvanized steel sheet reinforced with steel wire mesh covered with aluminum foil. The composite sheet shall provide a minimum 15x free expansion and shall contain no water soluble expansion ingredients. The composite sheet shall be UL Classified and tested to the requirements of ASTM E 814 (ANSI/UL 1479).

SPECIFIED DIVISIONS

Division 7	07840	Through-Penetration Firestopping
Division 15	15250	Mechanical Insulation-Fire Protection
Division 16	16050	Basic Electrical Materials & Methods

MAINTENANCE

No maintenance is ordinarily required, however, a periodic inspection of fire-resistance rated barriers is recommended to ensure that any new openings, modifications of previously installed firestops, or areas exhibiting physical damage, have been properly sealed or repaired. Subsequent sealing or repairs should be accomplished using SpecSeal® Products per the original approved design.

RETROFIT:

Adding Penetrants:

1. Remove firestop sealant/putty and composite sheet.
2. Add penetrating item(s).
3. Cut SpecSeal® Composite Sheet to accommodate new penetrating item(s).
4. Seal per the original UL Classified design.



PHYSICAL PROPERTIES

See Table A

INSTALLATION INSTRUCTIONS

Blank Opening

1. Apply 1/4" (6 mm) bead of SpecSeal® Sealant (Series SSS or Series LCI) or "rope" of SpecSeal® Firestop Putty (Series SSP) around the perimeter of the opening.
2. Position SpecSeal® Composite Sheet on top surface of floor or both surfaces of wall to overlap periphery of opening by 2" (51 mm). Galvanized steel sheet faces outward.
3. Secure SpecSeal® Composite Sheet to concrete surface using minimum 1-1/4" (31 mm) long by 1/8" (3.2 mm) diameter steel concrete screws in conjunction with nominal 1" (25 mm) diameter steel fender washers spaced 1" (25 mm) from each corner and 6" (152 mm) center-to-center. Install SpecSeal® Composite Sheet on both surfaces of wall.

Penetrant

1. Apply 1/4" (6 mm) bead of SpecSeal® Sealant (Series SSS or Series LCI) or "rope" of SpecSeal® Firestop Putty (Series SSP) around the perimeter of the opening.
2. Apply 1" (25 mm) bead of SpecSeal® Sealant or "rope" of SpecSeal® Firestop Putty around the circumference of the penetrating item at its egress from the SpecSeal® Composite Sheet. For cable bundles and cable trays, force sealant/putty to max extent within interstitial space between cables and apply sealant/putty to a minimum 2" (51 mm) height with the SpecSeal® Composite Sheet installed at the midheight of the 2" (51 mm) high seal.
3. Position SpecSeal® Composite Sheet on top surface of floor or both surfaces of wall to overlap periphery of opening by 2" (51 mm). Cut sheet to follow contours of penetrating item tightly. Galvanized steel sheet faces outward.
4. Cover seams between penetrating items and between penetrating items and periphery of opening with sheet steel to span 2" (51 mm) beyond each side of the seam. Secure the sheet steel to the SpecSeal® Composite Sheet with No. 10 self-tapping, self-drilling steel sheet metal screws spaced 1 in. (25 mm) from each end and 6" (152 mm) center-to-center.
5. Secure SpecSeal® Composite Sheet to concrete surface using minimum 1-1/4" (31 mm) long by 1/8" (3.2 mm) diameter steel concrete screws in conjunction with nominal 1" (25 mm) diameter steel fender washers spaced 1" (25 mm) from each corner and 6" (152 mm) center-to-center. Install SpecSeal® Composite Sheet on both surfaces of wall.

TECHNICAL SERVICE

Specified Technologies Inc. provides toll free technical support to assist in product selection and appropriate installation design. UL Systems, Material Safety Data Sheets, and other technical information is available at the Technical Library at www.stifirestop.com.

PRECAUTIONARY INFORMATION

Consult Material Safety Data Sheet for additional information on the safe handling and disposal of this material.

AVAILABILITY

SpecSeal® Composite Sheet is available from authorized STI distributors. Consult factory for names and locations of nearest sales representatives or distributors. Available sizes and additional SpecSeal® Products are listed below.

TABLE D: ORDERING INFORMATION

CAT. NO. DESCRIPTION

CS1628	16 by 28 in. (41 by 71 cm) composite sheet
CS2436	24 by 36 in. (61 by 92 cm) composite sheet
CS3636	36 by 36 in. (92 by 92 cm) composite sheet
CS3641	36 by 41 in. (92 by 104 cm) composite sheet
CS2852	28 by 52 in. (71 by 132 cm) composite sheet

CITY OF NEW YORK MEA 424-05-M

IMPORTANT NOTICE: All statements, technical information, and recommendations contained herein are based upon testing believed to be reliable, but the accuracy and completeness thereof is not guaranteed.

WARRANTY

Specified Technologies Inc. manufactures its goods in a manner to be free of defects. Should any defect occur in its goods (within one year), Specified Technologies Inc., upon prompt notification, will at its option, exchange or repair the goods or refund the purchase price.

LIMITATIONS AND EXCLUSIONS:

THIS WARRANTY IS IN LIEU OF ALL OTHER REPRESENTATIONS EXPRESSED OR IMPLIED (INCLUDING THE IMPLIED WARRANTIES OF MERCHANTABILITY OR FITNESS FOR USE) AND UNDER NO CIRCUMSTANCES SHALL SPECIFIED TECHNOLOGIES INC. BE RESPONSIBLE FOR ANY INCIDENTAL OR CONSEQUENTIAL PROPERTY DAMAGE OR LOSSES. PRIOR TO USE, THE USER SHALL DETERMINE THE SUITABILITY OF THE PRODUCT FOR ITS INTENDED USE, AND THE USER ASSUMES ALL RISKS AND LIABILITY FOR SUBSEQUENT USE.

No statement or recommendation not contained herein shall have any force or effect unless in an agreement signed by officers of seller and manufacturer.

MADE IN THE USA – COPYRIGHT © 2008 SPECIFIED TECHNOLOGIES, INC.

TABLE A: PHYSICAL PROPERTIES

Product Name:	SpecSeal® Composite Sheet
Nominal Thickness:	0.1 in. (2.5 mm)
Nominal Weight:	1.4 lb/ft ² (6.9 kg/m ²) Intumescent
Expansion Begins:	350°F (177°C)
Volume Expansion:	15X (typical free expansion)
Max. In-Service Temperature:	130°F (54°C)
Radiation Exposure:	Unaffected
Shelf Life:	No Limit
VOC Content:	N.A.
STC Rating:	55



Specified Technologies Inc.

Specified Technologies Inc. • 200 Evans Way, Somerville NJ 08876
Phone: 800.992.1180 • Fax: 908.526.9623

