

Flextray™ - F.A.S.T. Underfloor System

The F.A.S.T. System is an innovative and flexible way to support and manage cables in raised floor applications. This Foldable, Adjustable, Stackable, Tool-less System uses Flextray, stands, and accessories to provide a variety of options for your project and the fastest installation time on the market. Best of all, it does not attach to the raised floor structure and can be installed either before or after floor is in place.



F.A.S.T. System Flextray

- Rounded ends on all wires
- UL Classified (see technical data for details)
- Depths: 2", 4", & 6" nominal
- Lengths: 24", 48", & 118"
- Use flat fitting (WBUFLT) for turns
- Wire Diameter: 0.191" (4.9mm)
- Standard finishes: **GLV**

Consult customer service for other available finishes

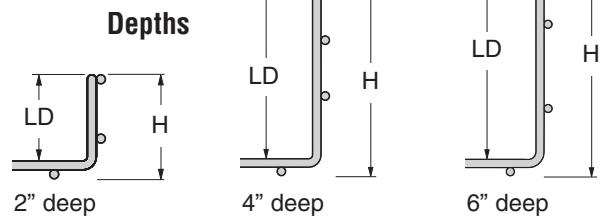
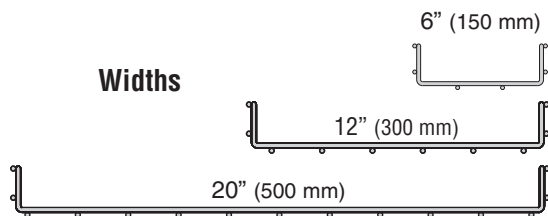
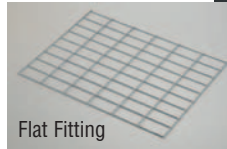
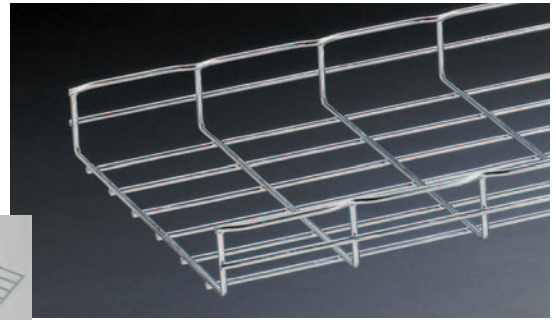

	Part Number	Width		Length		LD		H		Wt. Per Pc.	
		in.	mm	in.	mm	in.	mm	in.	mm	lbs.	kg
2" (50mm) deep	FTU2X6X2	6	150	23.9	603	1.63	41	2.02	51	2.03	0.92
	FTU2X6X4	6	150	47.5	1206	1.63	41	2.02	51	3.95	1.79
	FTU2X6X10	6	150	118.4	3008	1.63	41	2.02	51	9.72	4.41
	FTU2X12X2	12	300	23.9	603	1.63	41	2.02	51	2.99	1.36
	FTU2X12X4	12	300	47.5	1206	1.63	41	2.02	51	5.82	2.64
	FTU2X12X10	12	300	118.4	3008	1.63	41	2.02	51	14.32	6.50
	FTU2X20X2	20	500	23.9	603	1.63	41	2.02	51	4.28	1.94
	FTU2X20X4	20	500	47.5	1206	1.63	41	2.02	51	8.33	3.78
	FTU2X20X10	20	500	118.4	3008	1.63	41	2.02	51	20.45	9.28
4" (100mm) deep	FTU4X6X2	6	150	23.9	603	4.38	111	4.77	121	2.67	1.21
	FTU4X6X4	6	150	47.5	1206	4.38	111	4.77	121	5.20	2.36
	FTU4X6X10	6	150	118.4	3008	4.38	111	4.77	121	12.79	5.80
	FTU4X12X2	12	300	23.9	603	4.38	111	4.77	121	3.64	1.65
	FTU4X12X4	12	300	47.5	1206	4.38	111	4.77	121	7.08	3.21
	FTU4X12X10	12	300	118.4	3008	4.38	111	4.77	121	17.39	7.89
	FTU4X20X2	20	500	23.9	603	4.38	111	4.77	121	4.93	2.24
	FTU4X20X4	20	500	47.5	1206	4.38	111	4.77	121	9.58	4.35
	FTU4X20X10	20	500	118.4	3008	4.38	111	4.77	121	23.52	10.67
6" (150mm) deep	FTU6X6X2	6	150	23.9	603	6.38	162	6.77	172	3.32	1.51
	FTU6X6X4	6	150	47.5	1206	6.38	162	6.77	172	6.45	2.93
	FTU6X6X10	6	150	118.4	3008	6.38	162	6.77	172	15.85	7.19
	FTU6X12X2	12	300	23.9	603	6.38	162	6.77	172	4.28	1.94
	FTU6X12X4	12	300	47.5	1206	6.38	162	6.77	172	8.33	3.78
	FTU6X12X10	12	300	118.4	3008	6.38	162	6.77	172	20.45	9.28
	FTU6X20X2	20	500	23.9	603	6.38	162	6.77	172	5.57	2.53
	FTU6X20X4	20	500	47.5	1206	6.38	162	6.77	172	10.83	4.91
	FTU6X20X10	20	500	118.4	3008	6.38	162	6.77	172	26.59	12.06
Flats	WBUFLT	20	500	24	604	-	-	-	-	2.96	1.34
	WBUFLT-12	12	250	24	604	-	-	-	-	1.50	0.68
	WBUFLT-06	6	150	24	604	-	-	-	-	1.00	0.45

See page - 2 for finish information

Flextray™ - F.A.S.T. Underfloor System

Stands

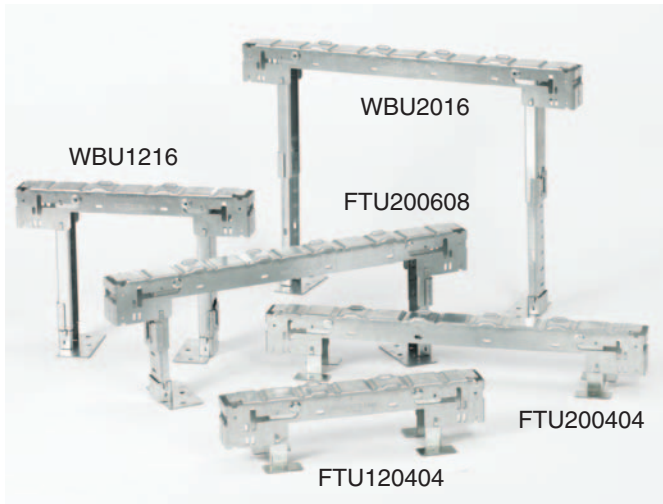

- No tools required for installation
- Formed top surface free of protrusions or sharp edges
- Up to 6" height adjustment
- Inside and outside leg positioning
- Folded and boxed for ease in shipping
- Patent Pending
- Stand part number includes:
 - one (1) stand
 - two (2) feet
 - two (2) adhesive pads
 - two (2) hold down clips
- Standard finish: Pre-Galvanized

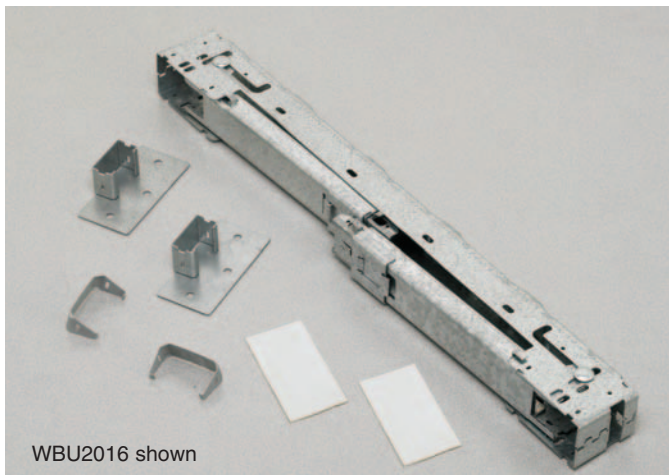

WBU2016 shown

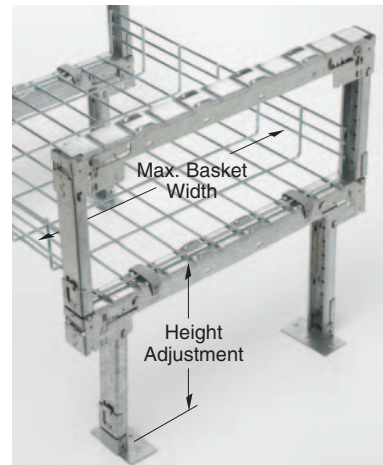

WBU2016 stands shown in double tier application.
Feet and adhesive pads not required for second tier assembly.

Part Number	Max. Basket Width		Height Adjustment		Stands Per Box	Wt. Per Box	
	in.	mm	in.	mm		lbs.	kg
FTU120404	12	300	4	101	2	1.82	0.82
FTU120608	12	300	6-8	152-203	2	2.79	1.26
WBU1216	12	300	10-16	254-406	2	7.44	3.37
WBU1224 *	12	300	18-24	457-609	2	9.06	4.11
WBU1231 *	12	300	25-31	635-787	2	10.52	4.77
FTU200404	20	500	4	101	2	2.34	1.06
FTU200608	20	500	6-8	152-203	2	3.36	1.52
WBU2016	20	500	10-16	254-406	2	8.56	3.88
WBU2024	20	500	18-24	457-609	2	10.20	4.62
WBU2031 *	20	500	25-31	635-787	2	11.64	5.28

* Legs are packed separately in box and not inserted in stand.

See page - 2 for finish information

Cantilever Kits & Accessories



- No tools required for installation
- Simple design for tiered applications
- Available in kits or individual parts
- Adjustable shelf height
- Formed top surface has no sharp edges
- Can be installed independent of raised floor
- Standard finish: Pre-Galvanized



Adjustability of shelf brackets

WBUCK812 Double Tier Cantilever Kit Shown with WBU2016 Stand



- WBUCK12** - Single Tier Cantilever Kit Includes
- (1) WBUCB12
 - (1) WBUL16
 - (1) WBUFCF
 - (2) WBUHD



- WBUCK812** - Double Tier Cantilever Kit Includes
- (1) WBUCB8
 - (1) WBUCB12
 - (1) WBUL24
 - (1) WBUFCF
 - (3) WBUHD



WBUCB8



WBUCB12

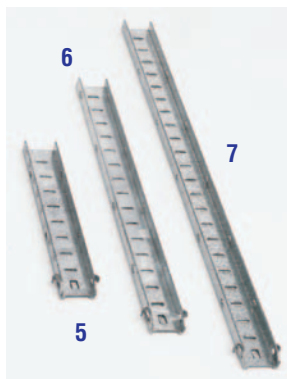
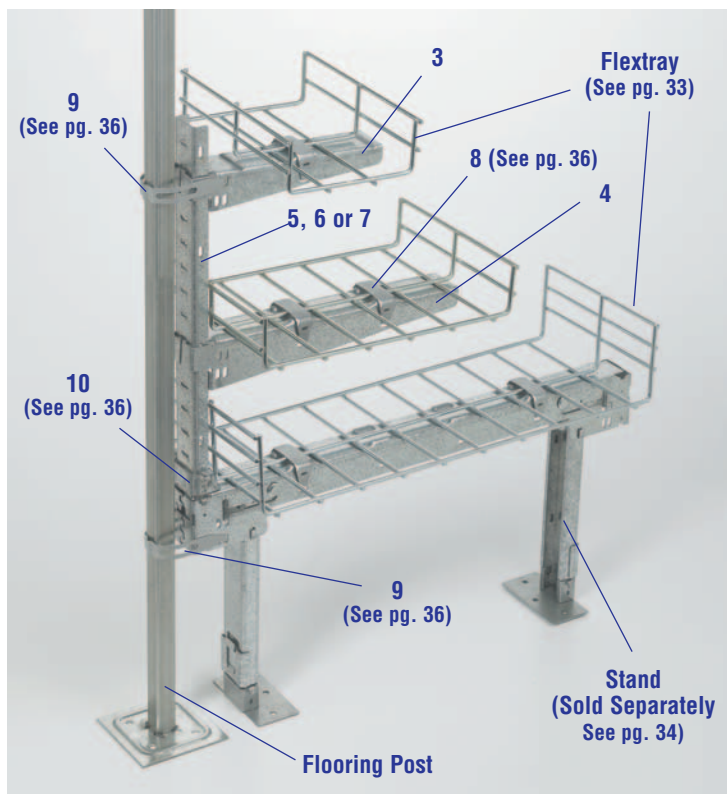

Part Number	Item #	Description	Max Height †		Box Qty.	Wt. Per Box	
			in.	mm		lbs.	kg
WBUCK12 *	1 ^Δ	Cantilever Kit - Single Tier with 12" Bracket	7.30	185	10	15.62	7.08
WBUCK812	2 ^Δ	Cantilever Kit - Double Tier with 8" & 12" Brackets	15.25	387	10	25.40	11.52
WBUCB8	3	8" Cantilever Bracket for 6" Flextray	-	-	10	5.51	2.50
WBUCB12	4	12" Cantilever Bracket for up to 12" Flextray	-	-	10	9.16	4.15
WBUL16	5	Short Vertical Support	7.30	185	10	4.37	1.98
WBUL24	6	Medium Vertical Support	15.25	387	10	8.45	3.83
WBUL31	7	Tall Vertical Support	22.25	565	10	12.07	5.47

* For use with 2" and 4" deep Flextray on the lower level. † Height - from top of stand ^Δ Stand not included
See page - 2 for finish information

Flextray™ - F.A.S.T. Underfloor System

Hold Down Clip



- Spring steel clip to attach Flextray to stands
- No tools required for installation
- Holds both continuous and spliced wire sections securely
- Works with stands and cantilever brackets

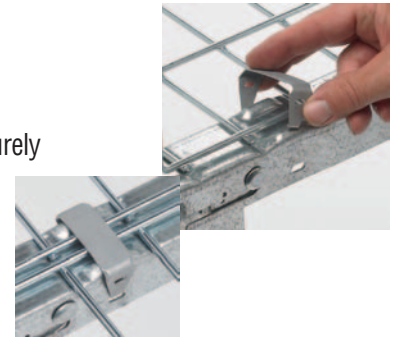

Part Number	Item #	Description	Box Qty.	Wt. Per Box	
				lbs.	kg
WBUHD	8	Basket Clip	50	1.10	0.50

Pedestal Clip



- Optional spring steel clip to give added rigidity to system
- Works with stands and cantilever brackets



Part Number	Item #	Description	Box Qty.	Wt. Per Box	
				lbs.	kg
WBUPC	9	Pedestal Clip	50	1.65	0.75

Cantilever Foot



- Secures vertical support into stand top
- Only required when stand legs are in the inner position

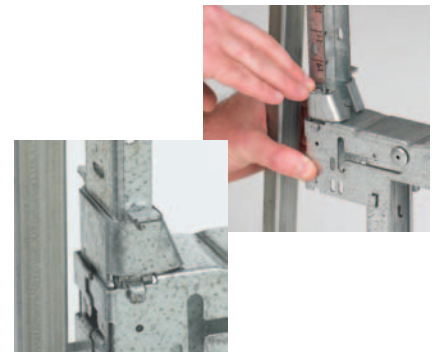

Part Number	Item #	Description	Box Qty.	Wt. Per Box	
				lbs.	kg
WBUCF	10	Cantilever Foot	50	8.65	3.92

Under Floor Stand

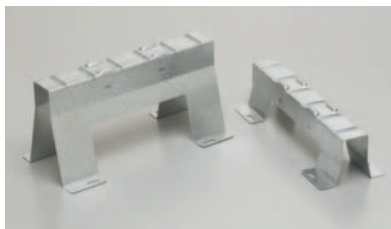

- Heights of 3", 4", 5" or 6"
- Leg cutout allows for airflow
- No tools required to mount Flextray to stand
- Use WBUHD hold down clips to secure basket
- Stand width is 12"
- Fasten to floor for maximum stability
- Floor mounting slot size: .313" (7.9mm) x .813" (20.6mm) for 1/4" hardware

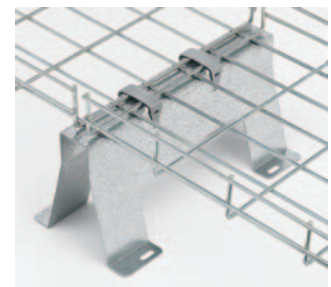

Part Number	Overall Height		Wt. Per Each	
	in.	mm	lbs.	kg
WBU1203	3	76	1.32	0.60
WBU1204	4	101	1.60	0.72
WBU1205	5	127	1.88	0.85
WBU1206	6	152	2.17	0.98

See page - 2 for finish information

L Bracket & Toolless Clip

- For use when access to ground floor is limited
- Use with round post sizes 0.9" (25mm) through 1.2" (30mm)
- Use with square posts
- Order clamps and brackets separately
- Built-in tab for hold down
- Tool-less Clip (plenum-rated material) - Snap-in locking pin securely holds basket to bracket

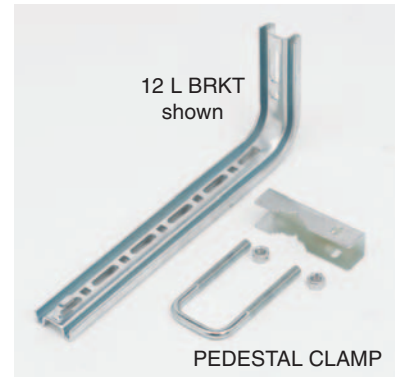

Part Number	Description	Qty.	Wt. Per Box	
			lbs.	kg
TOOLLESS CLIP	Tool-less Hold-Down Clip	50/Box	1.00	0.45

Brackets (Zinc Plated)

Part Number	System Width		Length		Box Qty.	Wt. Per Box	
	in.	mm	in.	mm		lbs.	kg
8 L BRKT	6-8	150-200	8	200	1	0.80	0.36
12 L BRKT	12	300	12	300	1	1.30	0.59

- Clamps to existing raised-access floor stanchion
- Use L BRKT (shown above) or full pedestal kit to support trays under the raised access floor (sold separately)
- For tray widths 2" (50mm) to 20" (500mm)
- *Pedestal Clamp Kit includes two (2) pedestal clamps, 28" (711mm) profile section, bolts & nuts
- Kits include hardware
- Finishes __: **EG**

Pedestal Clamp & Kit

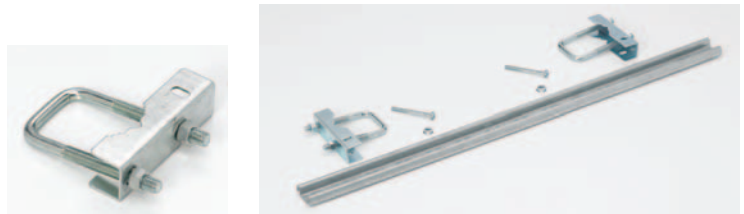

Part Number	Description	Qty./Box	Wt./Box	
			lbs.	kg
PEDESTAL CLAMP__	Pedestal Clamp	1	0.6	0.27
PEDESTAL KIT__	Pedestal Clamp Kit	1*	3.3	1.49

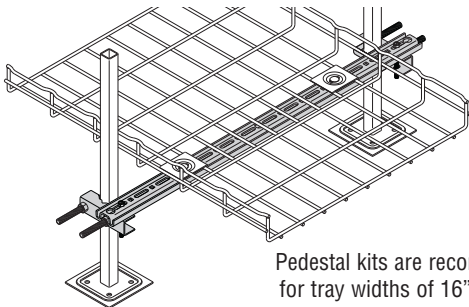

Pedestal kits are recommended for tray widths of 16" (400mm) or greater

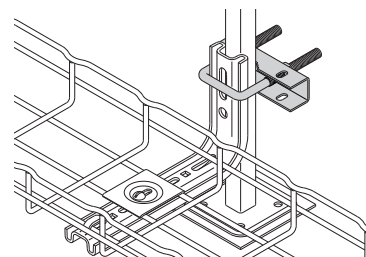

See page - 2 for finish information

Under Floor Support Bracket

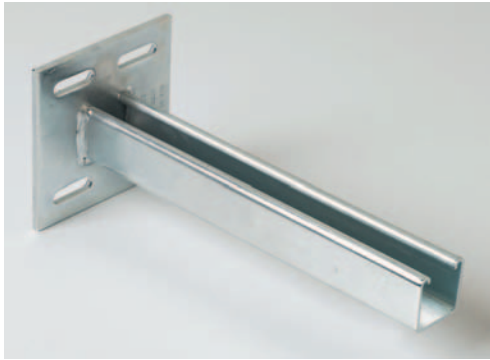

- Under Floor Support Bracket provides rugged support for Flextray System from access floor post.
- To complete the installation, the following hardware must be ordered separately.
 - (2) - B501 U-Bolts
 - (1) - SUPT WASHER Hold Down
 - (1) - 1/4"-20 x 1" Slotted Head Screw
 - (1) - N224WO Channel Nut
- Finish: **ZN**

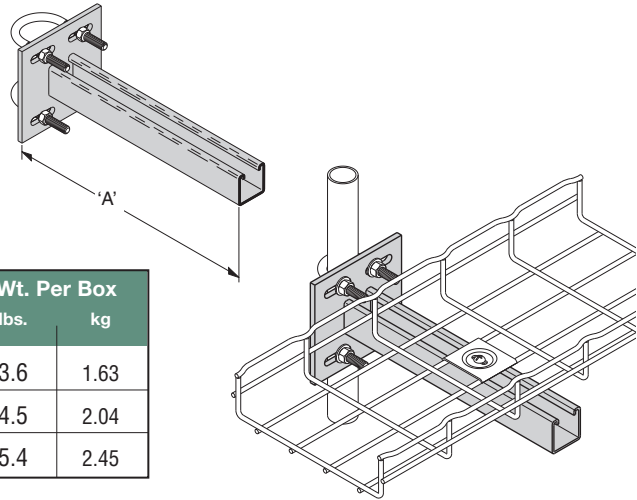

Part Number	'A'		Thread		Box Quantity	Wt. Per Box	
	in.	mm	in.	mm		lbs.	kg
B409UF-12	12"	300	12"	300	1	3.6	1.63
B409UF-18	18"	450	18"	450	1	4.5	2.04
B409UF-21	21"	533	21"	533	1	5.4	2.45

U-Bolts



- Designed for attachment of Under Floor Support Brackets to access floor post. Each U-Bolt includes two (2) hex nuts.
- Finish: **ZN**

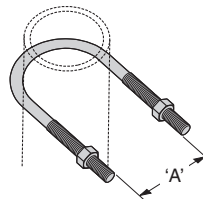

Part Number	'A'		Thread Size	Box Quantity	Wt. Per Box	
	in.	mm			lbs.	kg
B501-1	1 3/8"	30	5/16"-18	50	7.0	3.17
B501-1 1/2	2"	50	5/16"-18	50	8.0	3.63
B501-2	2 7/16"	62	3/8"-16	20	5.4	2.45
B501-2 1/2	2 15/16"	75	3/8"-16	25	8.0	3.63

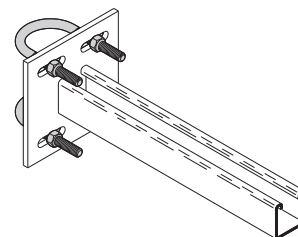

See page - 2 for finish information

Flextray™ - F.A.S.T. Underfloor System

- Attaches up to #1 ground wire to each tray section when separate ground wire is required
- Used for UL grounding compliance.
- When using color powder coated finish or paint, coating must be removed at the points of contact.
- Finish: Copper Plated

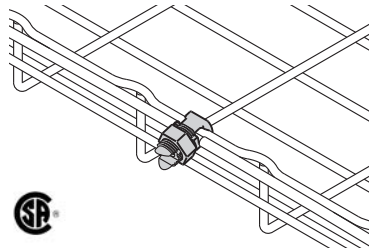

Ground Bolt



Part Number	Description	Qty./Box	Wt./Box	
			lbs.	kg
GROUND BOLT	Ground Bolt	1	0.11	0.05

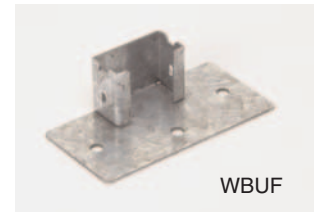

Adhesive & Feet

- WBUTAPE - Double-sided adhesive pads for temporary positioning of floor stands
Pad Size: 2" (50mm) x 4" (100mm)
- WBUFA - Adhesive to secure stand to floor

Part Number	Description	Box Qty.	Wt. Per Box	
			lbs.	kg
WBUF	Stand Foot	10	2.36	1.07
WBUTAPE	Double-Sided Tape	50	2.50	1.13
WBUFA	Floor Adhesive	1 Gallon	10.78	4.89

Floor Stand

- Non-metallic snap lock floor stand is designed for use under access floors.
- Floor stand elevates Flextray System 1⁵/₈" (41.3mm) above the floor.
- To attach floor stand, use Liquid Nails™ or anchors.
- Elevation increments of 1³/₈" (35mm) can be obtained by stacking floor stands.
- Sized for 1/4" hardware (order separately).
- Material: Black Plenum-rated Plastic

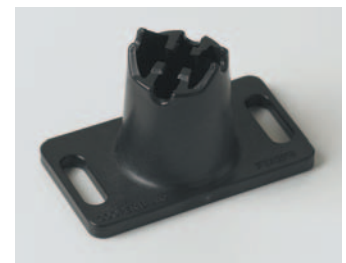
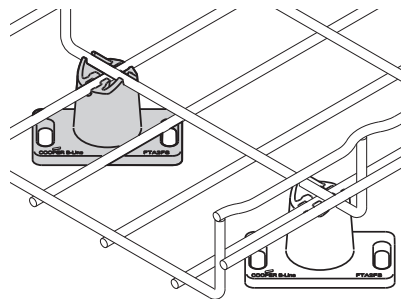

Part Number	Wt. Per Pc.		Box Quantity
	lbs.	kg	
FTA2FS	0.44	0.20	10

See page - 2 for finish information